

CODE 8

**OECD STANDARD CODE FOR THE OFFICIAL TESTING
OF PROTECTIVE STRUCTURES ON AGRICULTURAL
AND FORESTRY TRACKLAYING TRACTORS**

TABLE OF CONTENTS

1. DEFINITIONS	3
1.1 Tracklaying tractors.....	3
1.2 Rolling Over Protective Structure (ROPS).....	3
1.3 Track.....	3
1.4 Protective structure.....	3
1.5 Tractor frame.....	4
1.6 Protective structure-tractor frame assembly.....	4
1.7 Bedplate.....	4
1.8 Seat index point (SIP).....	4
1.9 Deflection-limiting volume (DLV)	4
1.10 Vertical reference plane.....	4
1.11 Lateral simulated ground plane	4
1.12 Vertical simulated ground plane.....	5
1.13 Unballasted mass.....	5
1.14 Permissible measurement tolerances	5
1.15 Symbols	5
2. FIELD OF APPLICATION.....	5
3. RULES AND DIRECTIONS	6
3.1 General regulations.....	6
3.2 Apparatus.....	6
3.3 Test conditions.....	8
3.4 Test procedure	8
3.5 Conditions for acceptance	11
3.6 Extension to other tractor models.....	12
3.7 Labelling.....	13
3.8 Cold weather performance of protective structures.....	13
3.9 Seatbelt anchorage performance (optional).....	14
SPECIMEN TEST REPORT	36
1. SPECIFICATIONS OF TEST TRACTOR	36
2. SPECIFICATIONS OF PROTECTIVE STRUCTURE.....	37
3. TEST RESULTS	39
SPECIMEN TECHNICAL EXTENSION REPORT	42
1. SPECIFICATION OF TEST TRACTOR.....	42
2. SPECIFICATION OF PROTECTIVE STRUCTURE.....	43
3. TEST RESULTS (in case of a validation test)	45
SPECIMEN ADMINISTRATIVE EXTENSION REPORT.....	49

CODE 8

OECD STANDARD CODE FOR THE OFFICIAL TESTING OF PROTECTIVE STRUCTURES ON AGRICULTURAL AND FORESTRY TRACKLAYING TRACTORS

1. DEFINITIONS

1.1 *Tracklaying tractors*

Self-propelled track-laying vehicles, designed to carry out the following operations, primarily for agricultural and forestry purposes:

- to pull trailers;
- to carry, pull or propel agricultural and forestry tools or machinery and, where necessary, supply power to operate them with the tractor in motion or stationary.

1.2 *Rolling Over Protective Structure (ROPS)*

Roll-over protective structure (safety cab or frame), hereinafter called “protective structure”, means the structure on a tractor the essential purpose of which is to avoid or limit risks to the driver resulting from roll-over of the tractor during normal use.

The roll-over protective structure is characterized by the provision of space for a clearance zone large enough to protect the driver when seated either inside the envelope of the structure or within a space bounded by a series of straight lines from the outer edges of the structure to any part of the tractor that might come into contact with flat ground and that is capable of supporting the tractor in that position if the tractor overturns.

1.3 *Track*

1.3.1 Preliminary definition: median plane of the track

The median plane of the track is equidistant from the two planes containing its periphery at their outer edges.

1.3.2 Definition of track width

Track width is the distance between the median planes of the tracks.

1.3.3 Additional definition: median plane of the tractor

The vertical plane at right angles to the axle at its centre point is the median plane of the tractor.

1.4 *Protective structure*

System of structural members arranged on a tractor in such a way as to accomplish its primary purpose of reducing the likelihood of an operator being crushed should his tractor roll over. Structural members include any subframe, bracket, mounting, socket, bolt, pin, suspension or flexible shock absorber

used to secure the system to the tractor frame but exclude mounting provisions which are integral with the tractor frame.

1.5 Tractor frame

The main chassis or main load-bearing member(s) of the tractor which extend(s) over a major part of the tractor and upon which the protective structure is directly mounted.

1.6 Protective structure-tractor frame assembly

System consisting of the protective structure attached to the tractor frame.

1.7 Bedplate

A substantially rigid part of the test structure to which the tractor frame is attached for the purpose of the test.

1.8 Seat index point (SIP)

1.8.1 The seat index point (**SIP**) is located in the central longitudinal plane of the apparatus for determination when installed in the operator seat. The **SIP** is fixed with respect to the tractor and does not move with the seat through its range of adjustment and/or oscillation.

1.8.2 When determining the **SIP**, the seat shall be adjusted with all fore, aft, vertical and angular seat adjustments placed in their centre position. The suspension systems shall be set so that the seat is at the mid-point of its oscillation range with the weighted apparatus for determination of **SIP** in place.

1.8.3 The **SIP** must be established by means of the apparatus illustrated in Figure 8.1. The apparatus is placed on the seat. A 20 kg mass is added 40 mm in front of the **SIP** mark on the horizontal section of the apparatus. A horizontal force of about 100 N shall then be applied to the apparatus at the **SIP** (see F_0 in Figure 8.1). Finally, a further 39 kg mass shall be placed 40 mm in front of the **SIP** mark on the horizontal section of the apparatus.

1.9 Deflection-limiting volume (DLV)

That volume, related to the operator, which serves to set limits and deflections permissible when performing laboratory evaluations of the protective structure (Figure 8.2). It is an orthogonal approximation of the dimensions of a large, seated operator.

1.10 Vertical reference plane

A vertical plane, generally longitudinal to the tractor and passing through the seat index point and the centre of the steering wheel or of the control hand levers. Normally, the vertical reference plane coincides with the median plane of the tractor.

1.11 Lateral simulated ground plane

Surface on which a tractor, after rolling over, is assumed to come to a standstill with the tractor lying on its side. The simulated ground plane is determined as follows (see 3.5.1.2):

- a** upper member to which the force is applied;
- b** outermost point in end view of member as defined in **(a)** above;

- c vertical line through point defined in (b) above;
- d vertical plane parallel to vehicle's longitudinal centreline through the line defined in (c) above;
- e rotate plane described in d above, 15° away from the DLV about an axis which is perpendicular to the vertical line given in c above and also passes through the point described in b above; this establishes the simulated ground plane;

The simulated ground plane shall be established on an unloaded protective structure and shall move with the member to which the load is applied.

1.12 Vertical simulated ground plane

For a machine coming to rest in an upside-down position, the plane is defined by the top cross-member of the protective structure and that front (rear) part of the tractor likely to come in contact with flat ground at the same time as the protective structure and capable of supporting the upside-down tractor. The vertical simulated ground plane moves with the deformed protective structure

Note: The vertical simulated ground plane applies only to two-post protective structures

1.13 Unballasted mass

The mass of the tractor without ballasting devices. The tractor shall be in running order with tanks, circuits and radiator full, protective structure with cladding and any track equipment or additional front wheel drive components required for normal use. The operator is not included.

1.14 Permissible measurement tolerances

Time:	± 0.2 s
Distance:	± 0.5 %
Force:	± 1.0 %
Mass:	± 0.5 %

1.15 Symbols

D	(mm)	Deflection of the structure;
F	(N)	Force;
M	(kg)	Maximum tractor mass recommended by the tractor manufacturer. It shall be equal or superior to the unballasted mass as defined in paragraph 1.13;
U	(J)	Energy absorbed by the structure related to the tractor mass.

2. FIELD OF APPLICATION

This OECD Standard Code is applicable to tractors, propelled and steered by endless tracks, having at least two axles with track attachments, and with following features:

- 2.1 an unballasted tractor mass not less than 600 kg;
- 2.2 the ground clearance not more than 600 mm beneath the lowest point of the front and rear axles.

3. RULES AND DIRECTIONS

3.1 *General regulations*

3.1.1 The protective structure may be manufactured either by the tractor manufacturer or by an independent firm. In either case a test is only valid for the model of tractor on which it is carried out. The protective structure must be retested for each model of tractor to which it is to be fitted. However, testing stations may certify that the strength tests are also valid for tractor models derived from the original model by modifications to the engine, transmission and steering and front suspension (*see below 3.6: Extension to other tractor models*). On the other hand, more than one protective structure may be tested for any one model of tractor.

3.1.2 The protective structure submitted for test must be supplied attached in the normal manner to the tractor or tractor chassis on which it is used. The tractor chassis shall be complete including attaching brackets and other parts of the tractor that may be affected by loads imposed on the protective structure.

3.1.3 A protective structure may be designed solely to protect the driver in the event of the tractor overturning. Onto this structure it may be possible to fit weather protective for the driver, of a more or less temporary nature. This will usually be removed by the driver in warm weather. There are protective structures however, in which the cladding is permanent and warm weather ventilation provided by windows or flaps. As the cladding may add to the strength of the structure and if removable may well be absent when an accident occurs, all parts that can be so taken away by the driver will be removed for the purpose of the test. Doors, roof hatch and windows which can be opened shall be either removed or fixed in the open position for the test, so that they do not add to the strength of the protective structure. It shall be noted whether, in this position, they would create a hazard for the driver in the event of overturning.

Throughout the remainder of these rules, reference will only be made to testing the protective structure. It must be understood that this includes cladding not of a temporary nature.

A description of any temporary cladding supplied is to be included in the specifications. All glass or similar brittle material shall be removed prior to the test. Tractor and protective structure components which might sustain needless damage during the test and which do not affect the strength of the protective structure or its dimensions may be removed prior to the test if the manufacturer wishes. No repairs or adjustment may be carried out during the test.

3.1.4 Any component of the tractor contributing to the strength of the protective structure such as mudguards, which has been reinforced by the manufacturer, should be described and its measurements given in the test report.

3.2 *Apparatus*

3.2.1 Deflection-limiting volume

The **DLV** and its location shall be in accordance with ISO 3164:2013 (see Figure 8.3). The **DLV** shall be fixed firmly to the same part of the machine to which the operator's seat is secured, and shall remain there during the entire formal test period.

For track-laying tractors with an unballasted mass of less than 5 000 kg, fitted with a two-post front mounted protective structure, the **DLV** corresponds to Figures 8.4 and 8.5.

3.2.2 Zone of clearance and safeguard plane

The zone of clearance, as defined in Code 4 (Definitions Chapter, Section 1.6), must remain covered by the safeguard plane, *S*, as shown in Figures 8.2 and 8.4. The safeguard plane is defined as an oblique plane, perpendicular to the vertical longitudinal plane of the tractor, forming a tangent at the front with the protective structure and at the back with whichever of the following hard fixtures of the tractor prevents the aforementioned plane *S* from entering the zone of clearance, via:

- a housing or rigid part of the rear of the tractor;
- the tracks;
- an additional hard structure firmly mounted on the rear of the tractor.

3.2.3 Rear hard fixture test

If the tractor is fitted with a rigid section, a housing or other hard fixture placed behind the driver's seat, this fixture shall be regarded as a protective point, in the event of sideways or rear overturning. This hard fixture placed behind the driver's seat shall be capable of withstanding, without breaking or entering the zone of clearance, a downward force F_i where:

$$F_i = 15 M$$

applied perpendicularly to the top of the frame in the central plane of the tractor. The initial angle of application of force shall be 40° calculated from a parallel to the ground as shown in Figure 8.4. The minimum width of this rigid section shall be 500 mm (see Figure 8.5).

In addition, it shall be sufficiently rigid and firmly attached to the rear of the tractor.

3.2.4 Lashings

Facilities for securing the protective structure-tractor frame assembly to the bedplate, as described above, and for applying the horizontal and vertical loads shall be provided (see Figures 8.6 to 8.9).

3.2.5 Measuring instruments

The test apparatus shall be equipped with instruments for measuring the force applied to the protective structure and the deflection (deformation) of the structure.

The percentages below are nominal ratings of the accuracy of the instrumentation and shall not be taken to indicate that compensating tests are required.

Measure	Accuracy
Deflection of the protective structure	± 5 % of maximum deflection measured
Force applied to the protective structure	± 5 % of maximum force measured

3.2.6 Arrangements for load application

Loading arrangements for load application are shown in Figures 8.7, 8.10 to 8.13 (side loading), in Figures 8.8 and 8.9 (vertical loading) and Figure 8.14 (longitudinal loading).

3.3 Test conditions

3.3.1 The protective structure shall comply with production specifications and shall be fitted to the appropriate tractor model chassis in accordance with the manufacturer's declared method of attachment.

3.3.2 The protective structure - tractor frame assembly shall be secured to the bedplate so that the members connecting the assembly and the bedplate experience minimal deflection when the protective structure is side loaded. During side loading, the protective structure - tractor frame assembly shall not receive any support from the bedplate, other than that due to the initial attachment.

3.3.3 The protective structure shall be instrumented with the necessary equipment to obtain the required force-deflection data.

3.3.4 All tests shall be performed on the same protective structure. No repair or straightening of any protective structure - tractor member shall be carried out during or between the side and vertical loadings.

3.3.5 For side and longitudinal loading, connection to the bedplate shall be through the main housing or track frames (see Figures 8.6 to 8.8).

3.3.6 For vertical loading, there is no limitation on securing or supporting the protective structure-tractor frame assembly.

3.3.7 On completion of all the tests, permanent deflections of the protective structure shall be measured and recorded.

3.4 Test procedure

3.4.1 General

The test procedures shall consist of the operations described in 3.4.2, 3.4.3 and 3.4.4 in the order listed.

3.4.2 Side loading

3.4.2.1 The force-deflection characteristics shall be determined by side loading the top major longitudinal members of the protective structure.

For a protective structure having more than two posts, the side loading shall be applied through a load-distribution device having a length not greater than 80 per cent of the top member straight length **L** between the front and rear posts of the protective structure (see Figures 8.13 to 8.16). The initial loading shall be within the zone that is established by the vertical projection of two planes parallel to the front and rear planes of the **DLV** and located 80 mm outside of them.

3.4.2.2 For a protective structure with an overhead shield, having a two-post system, the initial loading shall be dictated by the total longitudinal distance between major, upper protective structure members **L** and the vertical projection of the front and rear planes of the **DLV**. The force (load) point shall not be within **L/3** distance from the posts.

Should the **L/3** point be between the vertical projection of the **DLV** and the posts, the force (load) point shall be moved away from the post until it enters the vertical projection of the **DLV** (see Figures 8.13 to 8.16). Any load distribution plate used shall not impede or restrict the rotation of the protective structure around a vertical axis during the loading and shall not distribute the load over a distance greater than 80 per cent of **L**.

The force shall be applied to the major, upper and longitudinal members except when a post structure is used without the cantilevered overhead shield. For this type of structure, the force shall be applied in line with the upper cross-member.

3.4.2.3 The initial direction of the force shall be horizontal and perpendicular to a vertical plane through the tractor's longitudinal centre-line.

3.4.2.4 As loading continues, the deformations of the protective structure - tractor frame assembly may cause the direction of the force to change; this is permissible.

3.4.2.5 Should the operator's seat be off the tractor's longitudinal centre-line, the loading shall be against the outermost side nearest the seat.

3.4.2.6 For on-centre-line seats, if mounting of the protective structure is such that different force-deflection relations are obtained from loading from left or right sides, the side loaded shall be that which will place the most severe requirements on the protective structure - tractor frame assembly.

3.4.2.7 The rate of deflection (application of load) shall be such that it can be considered static, i.e. less than or equal to 5 mm/s.

3.4.2.8 At deflection increments no greater than 25 mm at the point of application of the resultant load, the force and deflection shall be recorded and plotted (Figure 8.17).

3.4.2.9 The loading shall be continued until the protective structure has achieved both the force and energy requirements. The area under the resulting force-deflection curve (Figure 8.17) equals the energy.

3.4.2.10 The deflection used in calculating energy shall be that of the protective structure along the line of action of the force. The deflection should be measured at the mid-point of the loading.

3.4.2.11 Any deflection of members used to support load-application devices shall not be included in deflection measurements used for calculation of energy absorption.

3.4.3 Vertical loading

3.4.3.1 After removal of the side load, a vertical load shall be applied to the top of the protective structure.

3.4.3.2 The load shall be applied using a stiff beam with a width of 250 mm.

3.4.3.3 For structures having more than two posts, the vertical load shall be applied at both the front and the rear

3.4.3.3.1 Vertical loading at the rear (Figures 8.10, 8.11.a and 8.11.b)

3.4.3.3.1.1 The crushing beam shall be positioned across the rear uppermost structural members so that the resultant of the crushing forces is located in the vertical reference plane. The crushing force shall be applied and maintained for 5 seconds after cessation of any visually detectable movement of the protective structure.

3.4.3.3.1.2 Where the rear part of the protective structure roof will not sustain the full crushing force, the force shall be applied until the roof is deflected to coincide with the plane joining the

upper part of the protective structure with that part of the rear of the tractor capable of supporting the tractor when overturned. The force shall then be removed and the crushing beam repositioned over that part of the protective structure that would support the tractor when completely overturned. The crushing force shall then be applied.

3.4.3.3.2 Vertical loading at the front (Figures 8.10 to 8.12)

3.4.3.3.2.1 The crushing beam shall be positioned across the front uppermost structural members so that the resultant of the crushing forces is located in the vertical reference plane. The crushing force F shall be applied and maintained for 5 seconds after cessation of any visually detectable movement of the protective structure.

3.4.3.3.2.2 Where the front part of the roof of the protective structure will not sustain the full crushing force (Figures 8.12.a and 8.12.b), the force shall be applied until the roof is deflected to coincide with the plane joining the upper part of the protective structure with that part of the front of the tractor capable of supporting the tractor when overturned. The force shall then be removed and the crushing beam repositioned over that part of the protective structure that would support the tractor when completely overturned. The crushing force shall then be applied.

3.4.3.4 For a protective structure having a two-post system, the vertical loading shall be dictated by the total longitudinal distance between major upper protective structure members L and the vertical projection of the front and rear planes of the DLV. The force (load) point shall be at a distance not less than $L/3$ distance from the posts (see Figure 8.9).

Should the $L/3$ point be between the vertical projection of the DLV and the posts, the force (load) point shall be moved away from the post until it enters the vertical projection of the DLV.

For front-mounted protective structures having a two-post system without an overhead shield, the vertical loading shall be applied in line with the transverse member connecting the upper members.

3.4.4 Longitudinal loading

3.4.4.1 After removal of the vertical load, a longitudinal load shall be applied to the protection structure

3.4.4.2 The longitudinal load shall be applied at the deformed location of the originally established point, since the lateral (and vertical) loading of the protection structure is likely to result in permanent deformation of the structure. The originally established point is determined by the location of the load distributor and socket prior to any test being performed on the structure.

The load distribution device may span the width in cases where no rear (front) cross-member exists. In all other cases, the device may not distribute the load over a length greater than 80 % of the width, W , of the protection structure (see Figure 8.18).

3.4.4.3 The longitudinal load shall be applied to the upper structural members of the protection structure along the longitudinal centreline of the protection structure

3.4.4.4 The direction of loading shall be selected to place the most severe requirements on the protection structure/tractor frame assembly. The initial direction of loading shall be horizontal and parallel to the original longitudinal centreline of the tractor. Some additional factors to consider in deciding on the direction to apply the longitudinal load are:

- a) location of protection structure relative to DLV and the effect that longitudinal deflection of the protection structure would have on providing crush protection for the operator;
- b) tractor characteristics, e.g. other structural members of the tractor which may resist longitudinal deflection of the protection structure, that can limit direction of the longitudinal component of loading on the protection structure;
- c) experience which may indicate the possibility of longitudinal tipping or the tendency of a particular classification tractor to skew as it rotates about a longitudinal axis during an actual roll-over.

3.4.4.5 The rate of deflection shall be such that the loading may be considered static (see 3.4.2.7). This loading is to continue until the protection structure has achieved the force requirement(s).

3.5 *Conditions for acceptance*

3.5.1 General

3.5.1.1 During each test, no part of the protective structure shall enter the deflection-limiting volume. Also, the deformation of the protective structure shall not allow the simulated ground plane (defined in paragraphs 1.11 and 1.12) to enter the DLV.

3.5.1.2 The protective structure deflection during each test shall not cause the load side planes of the DLV to extend beyond or intersect the simulated ground plane (see Figures 8.19 and 8.20).

The protective structure shall not break away from the tractor frame due to failure of the tractor frame.

3.5.2 Requirements for the side loading force-energy, the vertical loading force and the longitudinal loading force

3.5.2.1 These requirements shall be met within the deflection(s) permitted in 3.5.1.1.

3.5.2.2 The side-load force and the minimum energy absorbed shall attain at least those given in Table 8.1, where:

F is the minimum force attained during side loading;

M (kg) is the tractor manufacturer's maximum recommended mass;

U is the minimum energy absorbed during side loading.

If the required force is attained before the energy requirement is met, the force may decrease but shall again attain the required level when the minimum energy is obtained or exceeded.

3.5.2.3 After removal of the side load, the protective structure-tractor frame assembly shall support a vertical force:

$$F = 20 M$$

for a period of 5 min or until any deformation has ceased, whichever is shorter.

3.5.2.4 The longitudinal-load force shall attain at least that given in Table 8.1, where **F** and **M** are defined at point 3.5.2.2.

3.6 *Extension to other tractor models*

3.6.1 Administrative extension

If there are changes in the make, denomination or marketing features of the tractor or protective structure tested or listed in the original test report, the testing station that has carried out the original test can issue an “administrative extension report”. This extension report shall contain a reference to the original test report.

3.6.2 Technical extension

When technical modifications occur on the tractor, the protective structure or the method of attachment of the protective structure to the tractor, the testing station that has carried out the original test can issue a “technical extension report” in the following cases:

3.6.2.1 Extension of the structural test results to other models of tractors¹.

The impact and crushing tests need not be carried out on each model of tractor, provided that the protective structure and tractor comply with the conditions referred to hereunder 3.6.2.1.1 to 3.6.2.1.5.

3.6.2.1.1 The structure shall be identical to the one tested;

3.6.2.1.2 The required energy shall not exceed the energy calculated for the original test by more than 5 per cent;

3.6.2.1.3 The method of attachment and the tractor components to which the attachment is made shall be identical;

3.6.2.1.4 Any components such as mudguards and bonnet that may provide support for the protective structure shall be identical;

3.6.2.1.5 The position and critical dimensions of the seat in the protective structure and the relative position of the protective structure on the tractor shall be such that the DLV would have remained within the protection of the deflected structure throughout all tests.

3.6.2.2 Extension of the structural test results to modified models of the protective structure

This procedure has to be followed when the provisions of paragraph 3.6.2.1 are not fulfilled, it may not be used when the method of attachment of the protective structure to the tractor does not remain of the same principle (e.g. rubber supports replaced by a suspension device):

3.6.2.2.1 Modifications having no impact on the results of the initial test (e.g. weld attachment of the mounting plate of an accessory in a non-critical location on the structure), addition of seats with different SIP location in the protective structure (subject to checking that the new DLV(s) remain(s) within the protection of the deflected structure throughout all tests).

¹ Original test reports referring to the old version of Code 8 can be extended to new tractor models with no requirement for a validation test until the deadline of 28 February 2009, provided that the structure and the tractor models meet the requirements of 3.6.2.1 or 3.6.2.2.1.

3.6.2.2.2 Modifications having a possible impact on the results of the original test without calling into question the acceptability of the protective structure (e.g. modification of a structural component, modification of the method of attachment of the protective structure to the tractor). A validation test can be carried out and the test results will be drafted in the extension report.

The following limits for this type extension are fixed:

3.6.2.2.2.1 no more than 5 extension may be accepted without a validation test;

3.6.2.2.2.2 the results of the validation test will be accepted for extension if all the acceptance conditions of the Code are fulfilled and if the force measured when the required energy level has been reached in the various horizontal load tests does not deviate from the force measured when the required energy has been reached in the original test by more than $\pm 7\%$ and the deflection measured² when the required energy level has been reached in the various horizontal load tests does not deviate from the deflection measured when the required energy has been reached in the original test report by more than $\pm 7\%$.

3.6.2.2.2.3 more than one protective structure modifications may be included in a single extension report if they represent different options of the same protective structure, but only one validation test can be accepted in a single extension report. The options not tested shall be described in a specific section of the extension report.

3.6.2.2.3 Increase of the reference mass declared by the manufacturer for a protective structure already tested. If the manufacturer wants to keep the same approval number it is possible to issue an extension report after having carried out a validation test (the limits of $\pm 7\%$ specified in 3.6.2.2.2.2 are not applicable in such a case).

3.7 Labelling

3.7.1 OECD labelling is optional. If it is utilised, it shall contain at least the following information:

3.7.1.1 OECD reference;

3.7.1.2 OECD approval number.

3.7.2 The label shall be durable and permanently attached to the protective structure so that it can be easily read and it shall be protected from environmental damage.

3.8 Cold weather performance of protective structures

3.8.1 If the protective structure is claimed to have properties resistant to cold weather embrittlement, the manufacturer shall give details which shall be included in the report.

3.8.2 The following requirements and procedures are intended to provide strength and resistance to brittle fracture at reduced temperatures. It is suggested that the following minimum material requirements

² Permanent + elastic deflection measured at the point when the required energy level is obtained.

shall be met in judging the protective structure's suitability at reduced operating temperatures in those countries requiring this additional operating protective.

3.8.2.1 Bolts and nuts used to attach the protective structure to the tractor and used to connect structural parts of the protective structure shall exhibit suitable controlled reduced temperature toughness properties.

3.8.2.2 All welding electrodes used in the fabrication of structural members and mounts shall be compatible with the protective structure material as given in 3.8.2.3 below.

3.8.2.3 Steel materials for structural members of the protective structure shall be of controlled toughness material exhibiting minimum Charpy V-Notch impact energy requirements as shown in Table 8.2. Steel grade and quality shall be specified in accordance with ISO 630-1,2,3,4:2011-2012.

Steel with an as-rolled thickness less than 2.5 mm and with a carbon content less than 0.2 per cent is considered to meet this requirement.

Structural members of the protective structure made from materials other than steel shall have equivalent low temperature impact resistance.

3.8.2.4 When testing the Charpy V-Notch impact energy requirements, the specimen size shall be no less than the largest of the sizes stated in Table 8.2 that the material will permit.

3.8.2.5 The Charpy V-Notch tests shall be made in accordance with the procedure in ASTM A 370-1979, except for specimen sizes which shall be in accordance with the dimensions given in Table 8.2.

3.8.2.6 Alternatives to this procedure are the use of killed or semi-killed steel for which an adequate specification shall be provided. Steel grade and quality shall be specified in accordance with ISO 630-1,2,3,4:2011-2012.

3.8.2.7 Specimens are to be longitudinal and taken from flat stock, tubular or structural sections before forming or welding for use in the protective structure. Specimens from tubular or structural sections are to be taken from the middle of the side of greatest dimension and shall not include welds.

3.9 *Seatbelt anchorage performance (optional)*

3.9.1 Scope

Seat belts are one of the operator restraint systems used for securing the driver in motor vehicles.

This recommended procedure provides minimum performance and tests requirements for seat belt anchorage for agricultural and forestry tractors.

It applies to the anchorage of pelvic restraint systems.

3.9.2 Explanation of terms used in the performance testing

3.9.2.1 The *seat belt assembly* is any strap or belt device fastened across the lap or pelvic girdle area designed to secure a person in a machine.

3.9.2.2 The *extension belt* is intended as any strap, belt, or similar device that aids in the transfer of seat belt loads.

3.9.2.3 The *anchorage* is intended as the point where the seat belt assembly is mechanically attached to the seat system or tractor.

3.9.2.4 The *seat mounting* is intended as all intermediary fittings (such as slides, etc.) used to secure the seat to the appropriate part of the tractor.

3.9.2.5 The *Operator Restraint System* is intended as the total system composed of seat belt assembly, seat system, anchorages and extension which transfers the seat belt load to the tractor.

3.9.2.6 *Applicable Seat Components* comprise all components of the seat whose mass could contribute to loading of the seat mounting (to the vehicle structure) during a roll-over event.

3.9.3 Test procedure

The procedure is applicable to a seat belt anchorage system provided for a driver or a person in addition to the driver carried by the tractor.

Only static tests for anchorages are given in this procedure.

If, for a given protective structure, a manufacturer provides more than one seat with identical components which transfer the load from the seatbelt anchorage to the seat mounting on the ROPS floor or tractor chassis, the Testing Station is authorized to test only one configuration, corresponding to the heaviest seat (*see also below*).

The seat shall be in position during the tests and fixed to the mounting point on the tractor using all intermediary fittings (such as suspension, slides, etc.) specified for the complete tractor. No additional non-standard fittings contributing to the strength of the construction may be used.

The worst case loading scenario for seat belt anchorage performance testing should be identified with consideration to the following points:-

- If the masses of alternative seats are comparable, those featuring seat belt anchorages which transfer loading through the seat structure (*e.g. via the suspension system and/or adjustment slides*), will be required to withstand much higher test loading. They are therefore likely to represent the worst case;
- If the applied loading will pass through the seat mountings to the vehicle chassis, the seat should be adjusted longitudinally to achieve the minimum amount of overlap of the mounting slides / rails. This will usually be when the seat is in the fully-rearward position but, if certain vehicle installations limit seat rearward travel, the fully-forward seat position may provide the worst case loading position. Observation of the amount of seat movement and mounting slide / rail overlap is required.

The anchorages shall be capable of withstanding the loads applied to the seat belt system using a device as shown in Figure 8.21. The seat belt anchorages shall be capable of these test loads applied with the seat adjusted in the worst position of the longitudinal adjustment to ensure that the test condition is met. The test loads shall be applied with the seat in the mid-position of the longitudinal adjustment if a worst position among the possible seat adjustments is not recognised by the testing station. For a suspended seat, the seat shall be set to the midpoint of the suspension travel, unless this is contradictory to a clearly stated instruction by the seat manufacturer. Where special instructions exist for the seat setting, these shall be observed and specified in the report.

After the load is applied to the seat system, the load application device shall not be repositioned to compensate for any changes that may occur to the load application angle.

3.9.3.1 Forward loading

A tensile force shall be applied in a forward and upward direction at an angle of $45^\circ \pm 2^\circ$ to the horizontal, as shown in Figure 8.22. The anchorages shall be capable of withstanding a force of 4 450 N. In the event that the force applied to the seat belt assembly is transferred to the vehicle chassis by means of the seat, the seat mounting shall be capable of withstanding this force plus an additional force equal to four times the force of gravity on the mass of all applicable seat components, applied $45^\circ \pm 2^\circ$ to the horizontal in a forward and upward direction, as shown in Figure 8.19.

3.9.3.2 Rearward loading

A tensile force shall be applied in a rearward and upward direction at an angle of $45^\circ \pm 2^\circ$ to the horizontal, as shown in Figure 8.23. The anchorages shall be capable of withstanding a force of 2 225 N. In the event that the force applied to the seat belt assembly is transferred to the vehicle chassis by means of the seat, the seat mounting shall be capable of withstanding this force plus an additional force equal to two times the force of gravity on the mass of all applicable seat components, applied $45^\circ \pm 2^\circ$ to the horizontal in a rearward and upward direction, as shown in Figure 8.23.

Both tensile forces shall be equally divided between the anchorages.

3.9.3.3 Seatbelt buckle release force (if required by the manufacturer)

The seat belt buckle shall open with a maximum force of 140 N following the load applications. This requirement is fulfilled for seat belt assemblies that satisfy the requirements of UN-ECE R-16 or Directive 77/541/EEC as last amended.

3.9.4 Test result

Condition of acceptance

Permanent deformation of any system component and anchorage area is acceptable under the action of the forces specified in 3.9.3.1 and 3.9.3.2. However, there shall be no failure allowing release of the seat belt system, seat assembly, or the seat adjustment locking mechanism.

The seat adjuster or locking device need not be operable after application of the test load.

The results of a test performed on an identical “operator restraint system” may be included in more than one test report provided that this system is fitted exactly in the same conditions.

The results of a test performed after the approval of the test report of the protective structure shall be drafted in a technical extension report.

Machine mass, M	Lateral load force, F	Lateral load energy, U	Vertical load force, F	Longitudinal load force, F
kg	N	J	N	N
800<M≤4630	6M	13000(M/10000) ^{1.25}	20M	4.8M
4630<M≤59500	70000(M/10000) ^{1.2}	13000(M/10000) ^{1.25}	20M	56000(M/10000) ^{1.2}
M>59500	10M	2.03M	20M	8M

Table 8.1
Force and energy equations

Specimen size	Energy at	
	- 30 °C	- 20 °C
mm	J	J ^{b)}
10 x 10 ^{a)}	11	27.5
10 x 9	10	25
10 x 8	9.5	24
10 x 7,5 ^{a)}	9.5	24
10 x 7	9	22.5
10 x 6.7	8.5	21
10 x 6	8	20
10 x 5 ^{a)}	7.5	19
10 x 4	7	17.5
10 x 3.5	6	15
10 x 3	6	15
10 x 2.5 ^{a)}	5.5	14

Table 8.2
Minimum Charpy V-notch impact energies

- a) Indicates preferred size. Specimen size shall be no less than largest preferred size that the material permits.
- b) The energy requirement at – 20 °C is 2.5 times the value specified for – 30 °C. Other factors affect impact energy strength, i.e. direction of rolling, yield strength, grain orientation and welding. These factors shall be considered when selecting and using steel.

Dimensions in millimetres

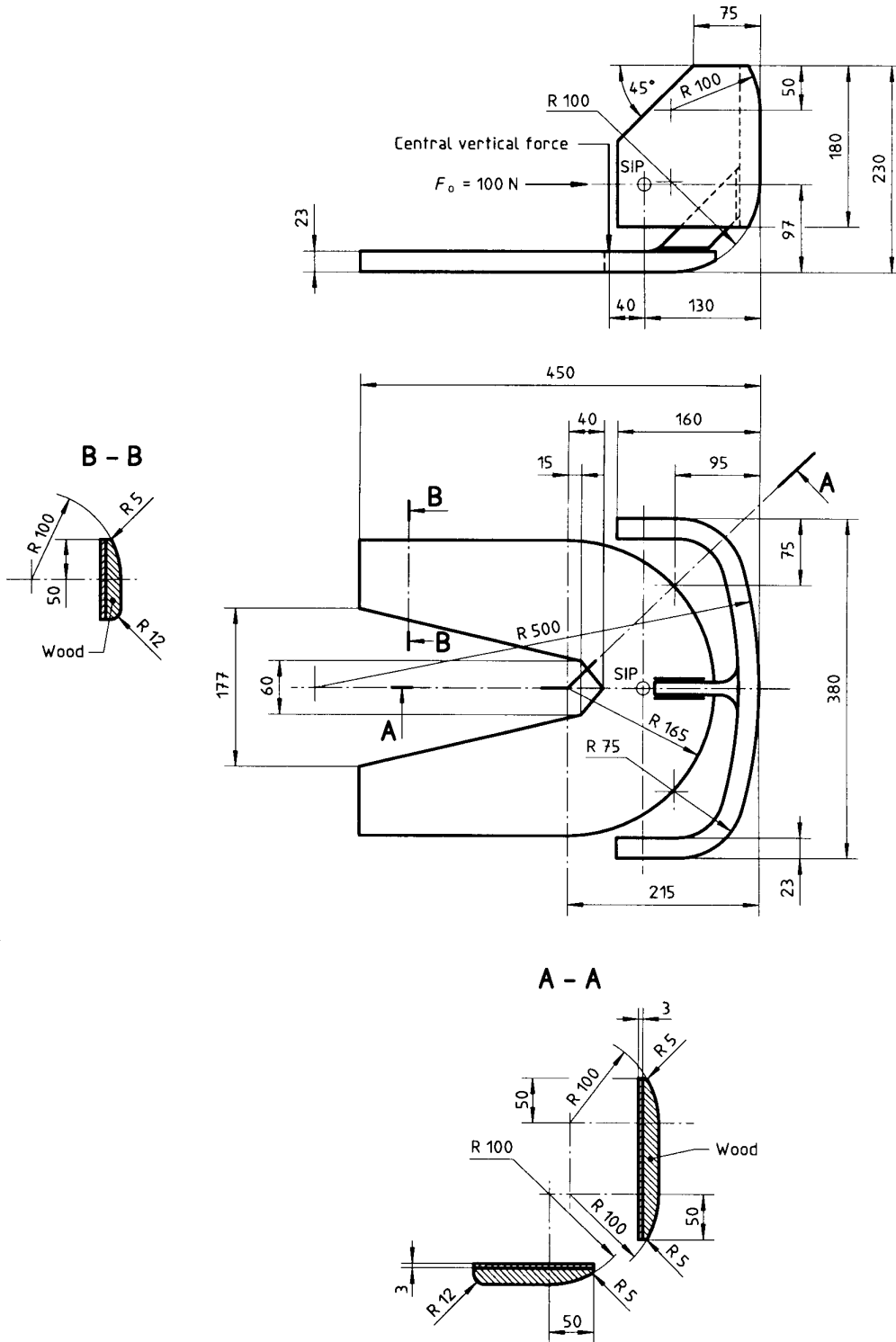

Figure 8.1

Apparatus for determination of seat index point (SIP)

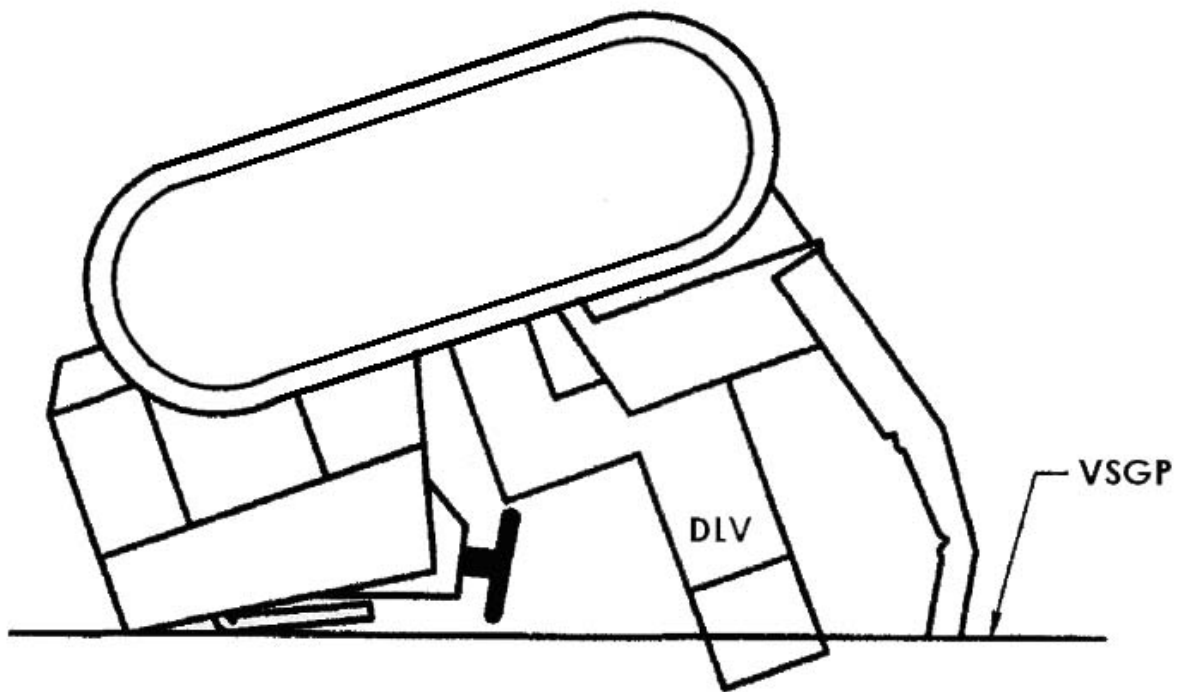
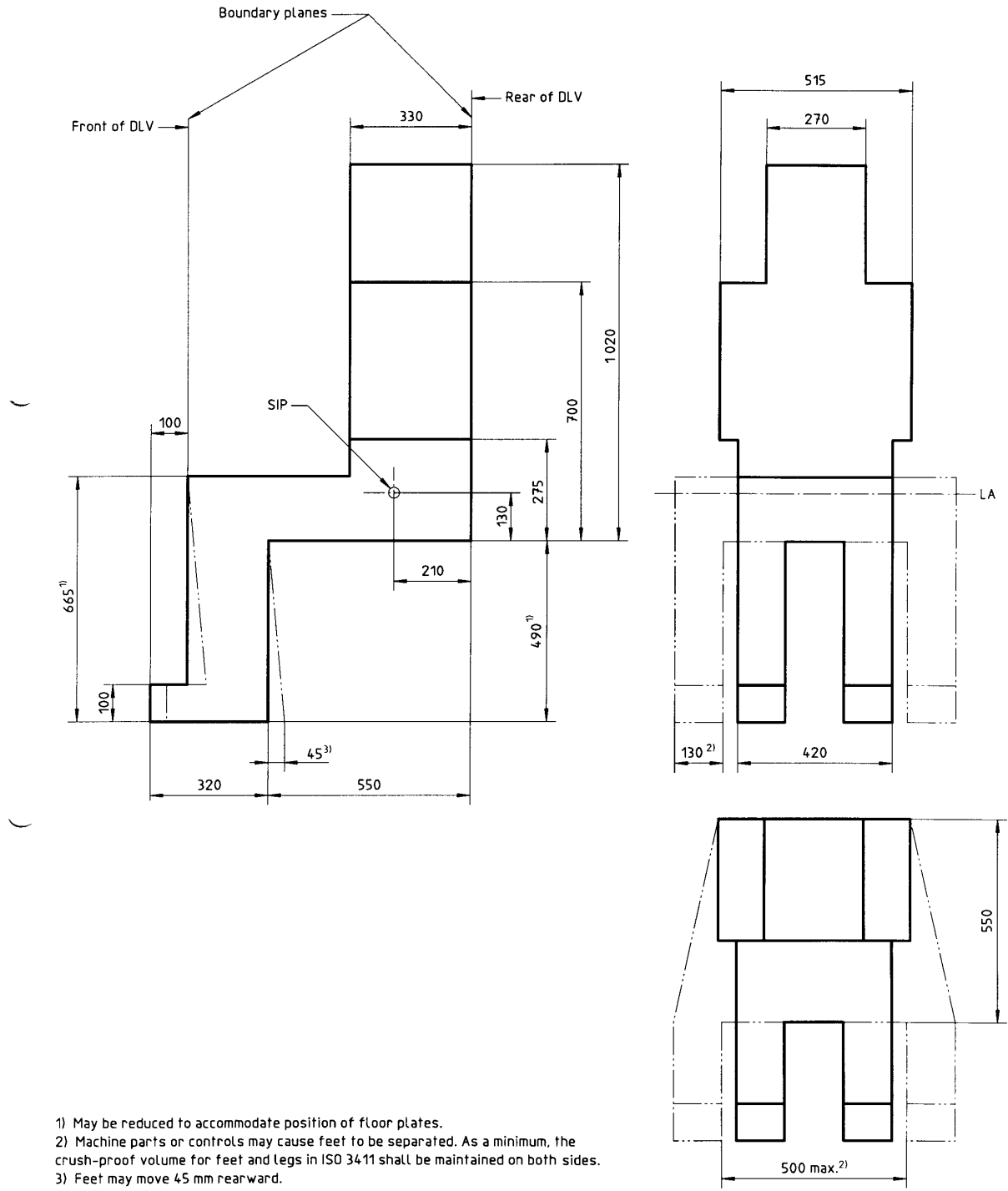

Figure 8.2
Intrusion of vertical simulated ground plane into DLV

Dimensions in millimetres,
general tolerance ± 5 mm



- 1) May be reduced to accommodate position of floor plates.
- 2) Machine parts or controls may cause feet to be separated. As a minimum, the crush-proof volume for feet and legs in ISO 3411 shall be maintained on both sides.
- 3) Feet may move 45 mm rearward.

Figure 8.3

Deflection-limiting volume (DLV)

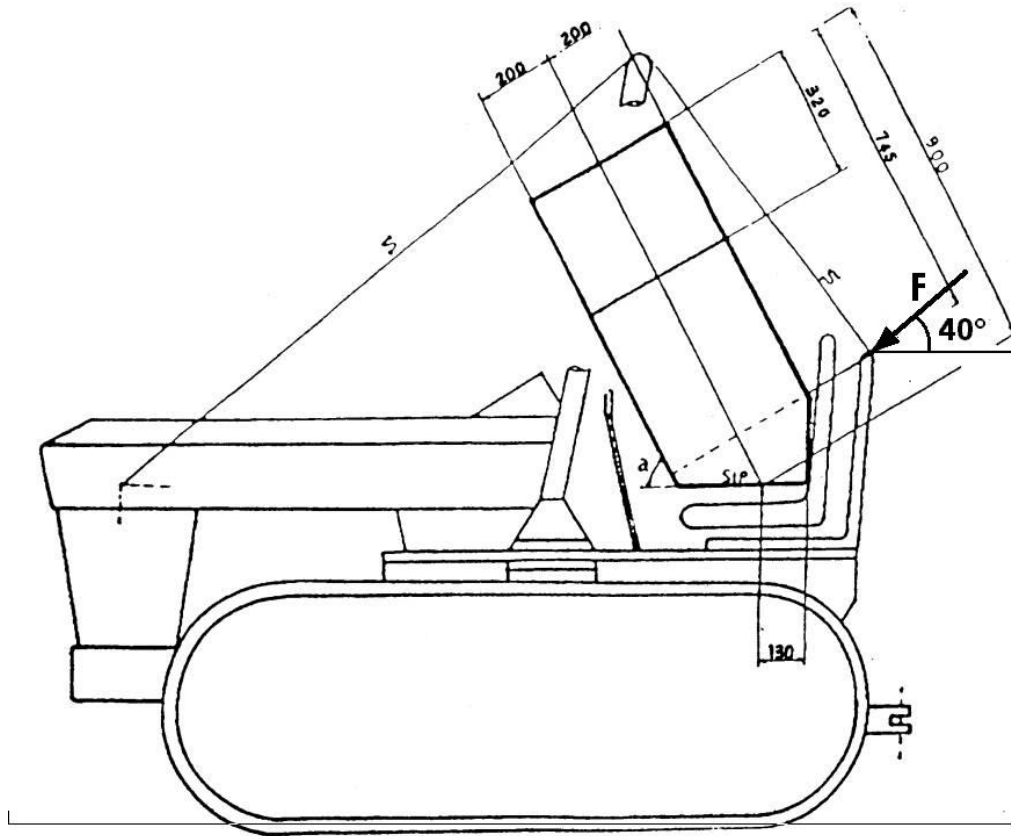

Figure 8.4

**Two-post front-mounted protective structure, side view
Deflection-limiting volume (DLV)**

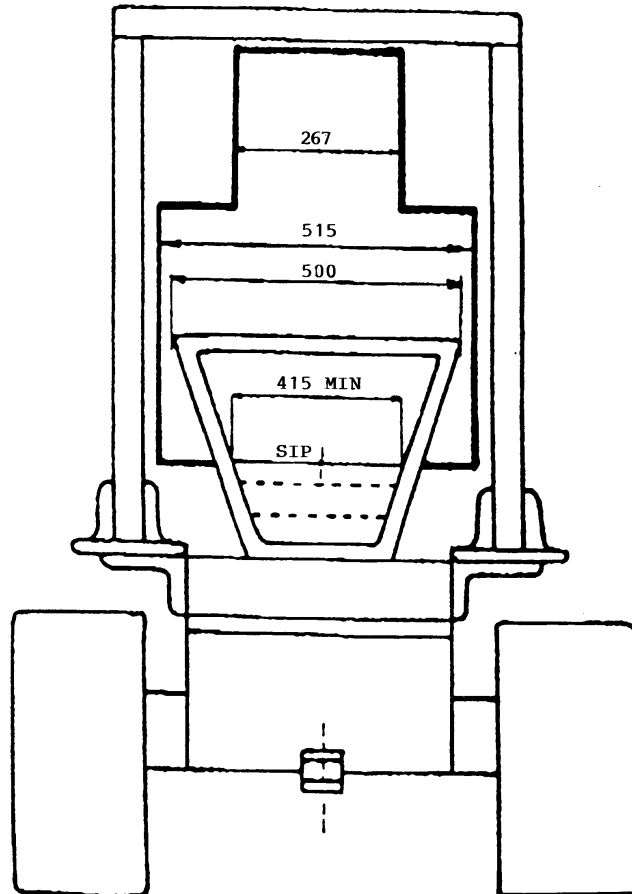

Figure 8.5

Two-post front-mounted protective structure, rear view

Deflection-limiting volume (DLV)

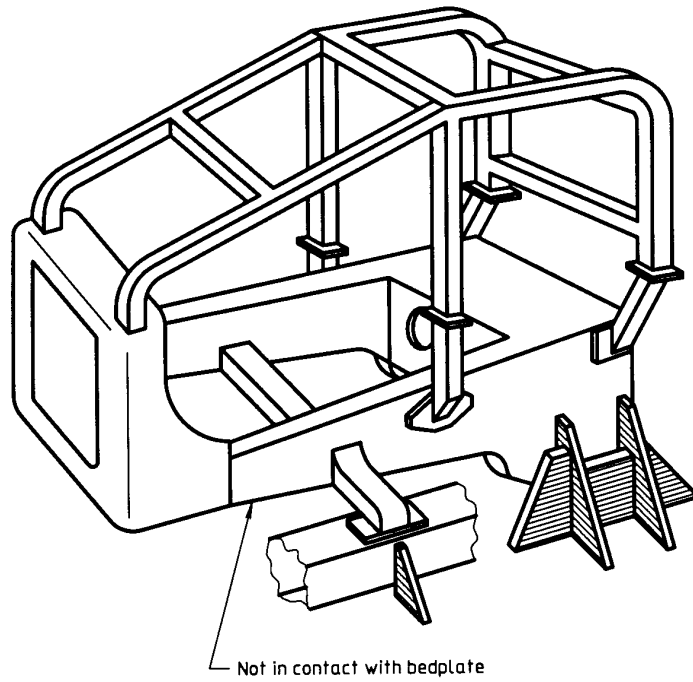

Figure 8.6

Typical arrangement for fastening the protective structure to the tractor frame

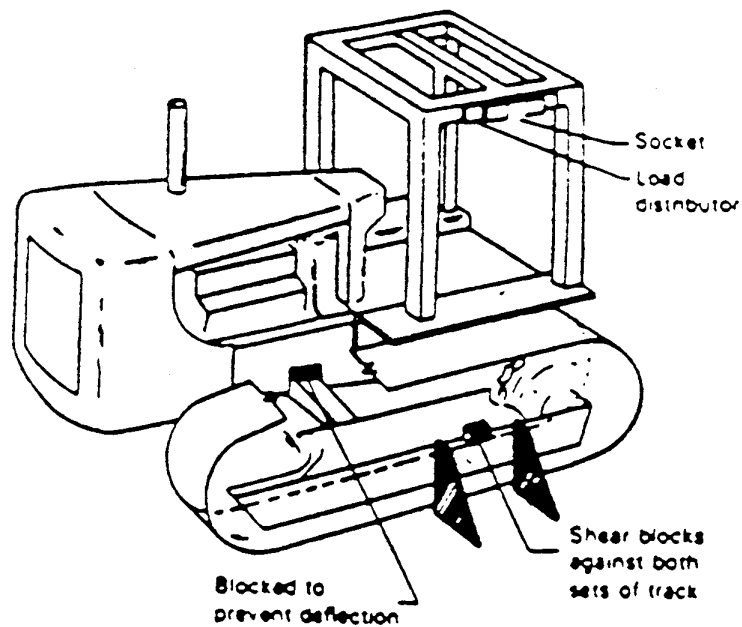

Figure 8.7

Typical arrangement for protective structure side loading

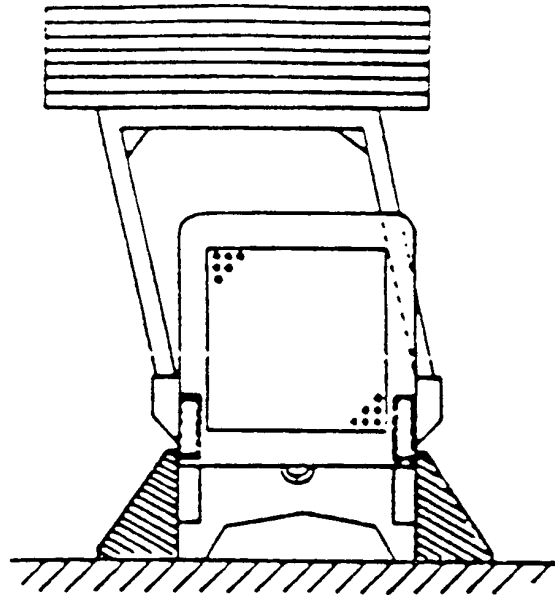

Figure 8.8

Typical arrangement for fixing the tractor frame and applying vertical load

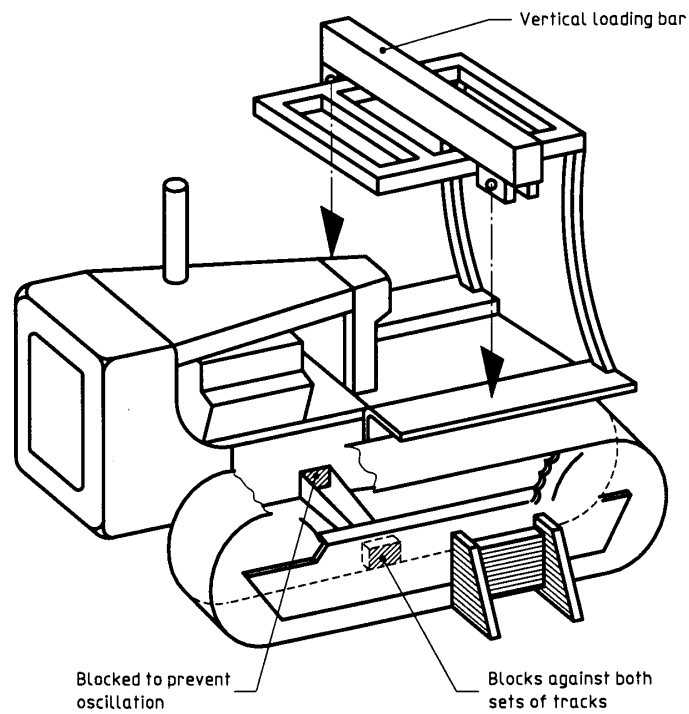

Figure 8.9

Typical arrangement for applying vertical load to the protective structure

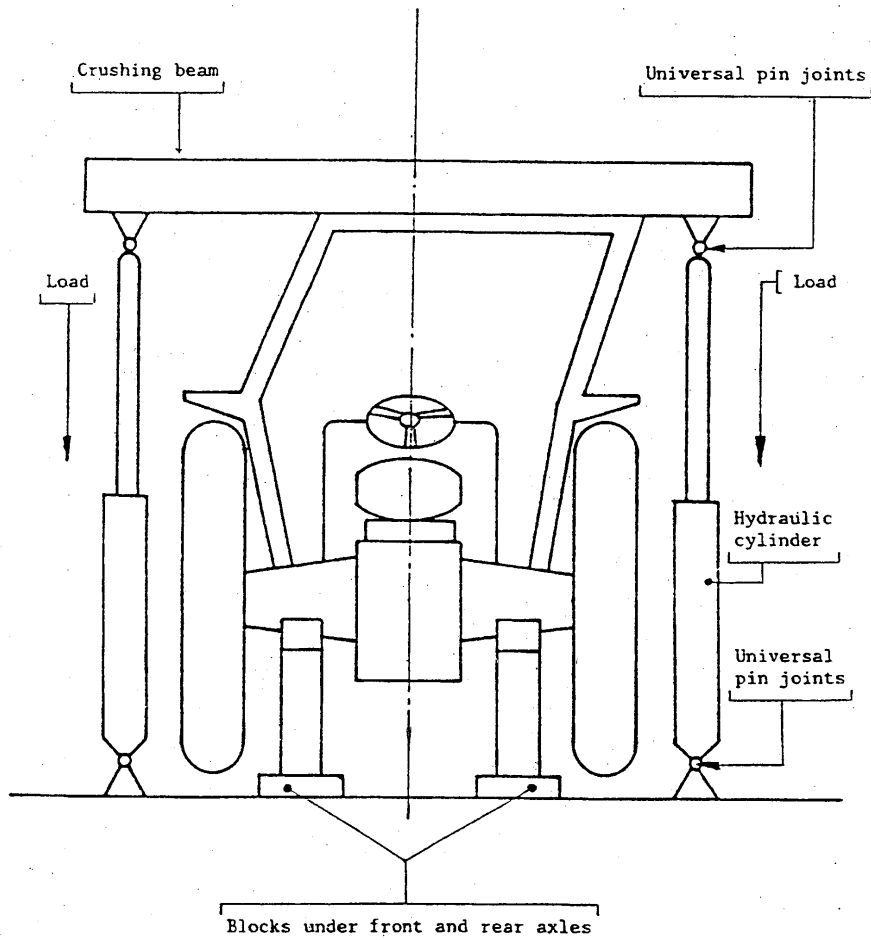

Figure 8.10

Example of an arrangement for crushing test

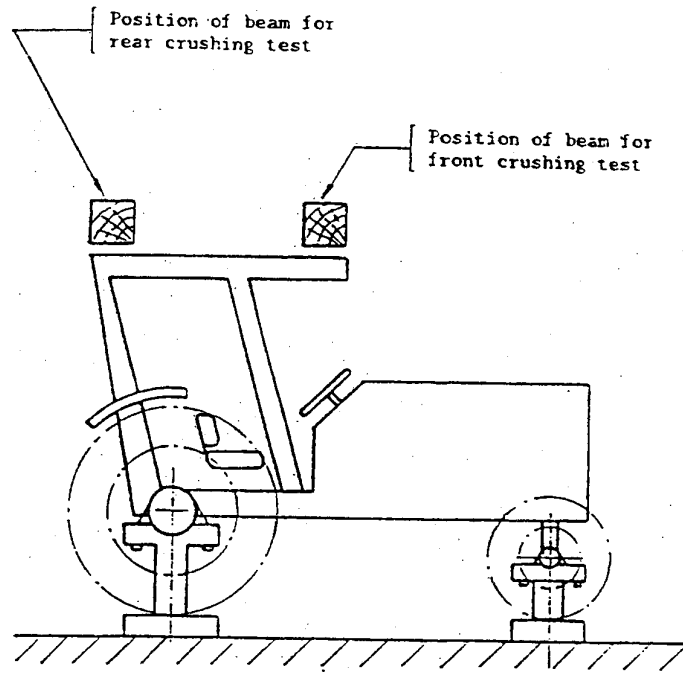

Figure 8.11.a Protective cab

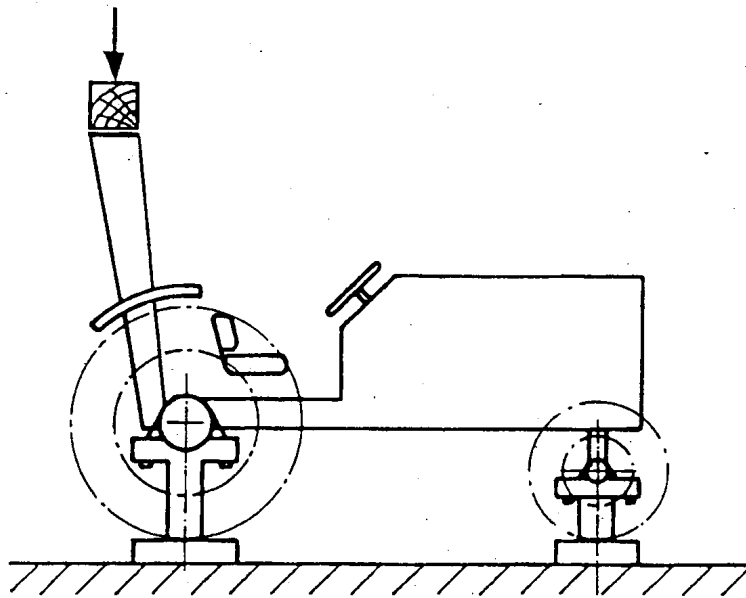

Figure 8.11.b Rear roll bar frame

Figures 8.11

**Position of beam for front and rear crushing tests,
protective cab and rear roll bar frame**

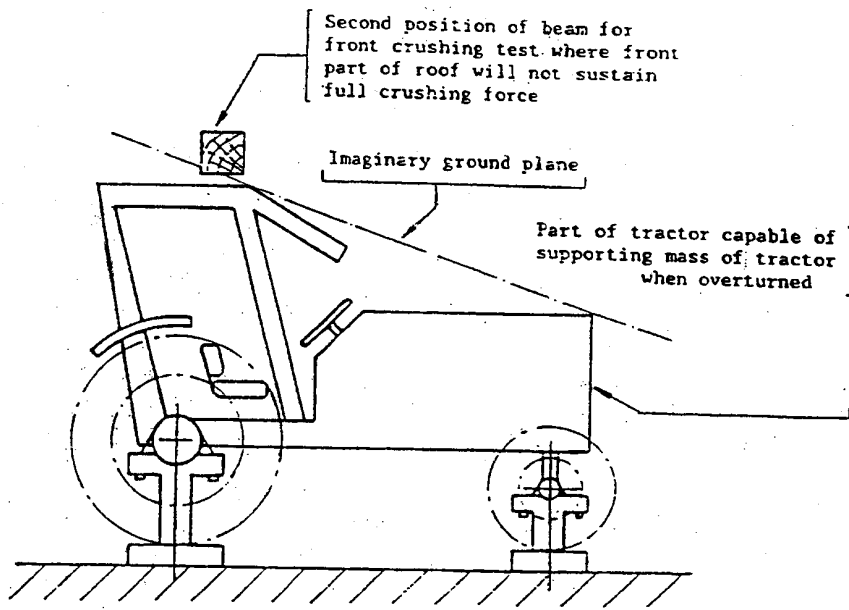

Figure 8.12.a Protective cab

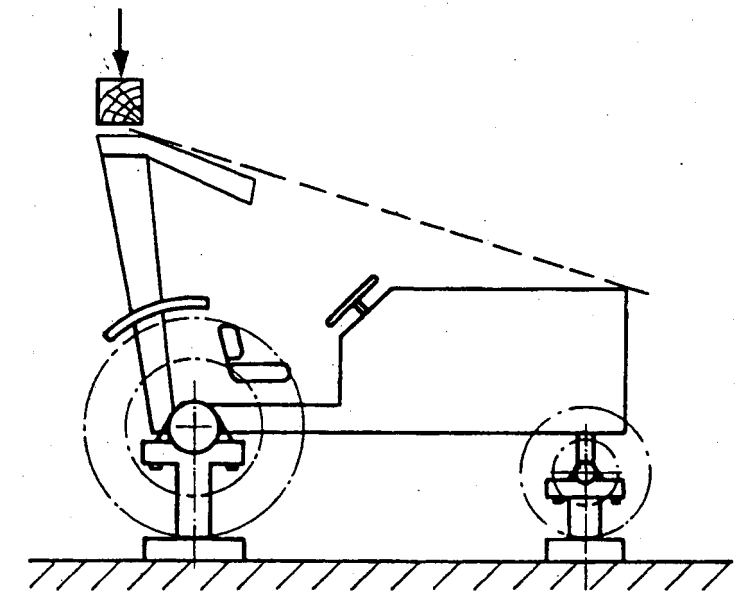
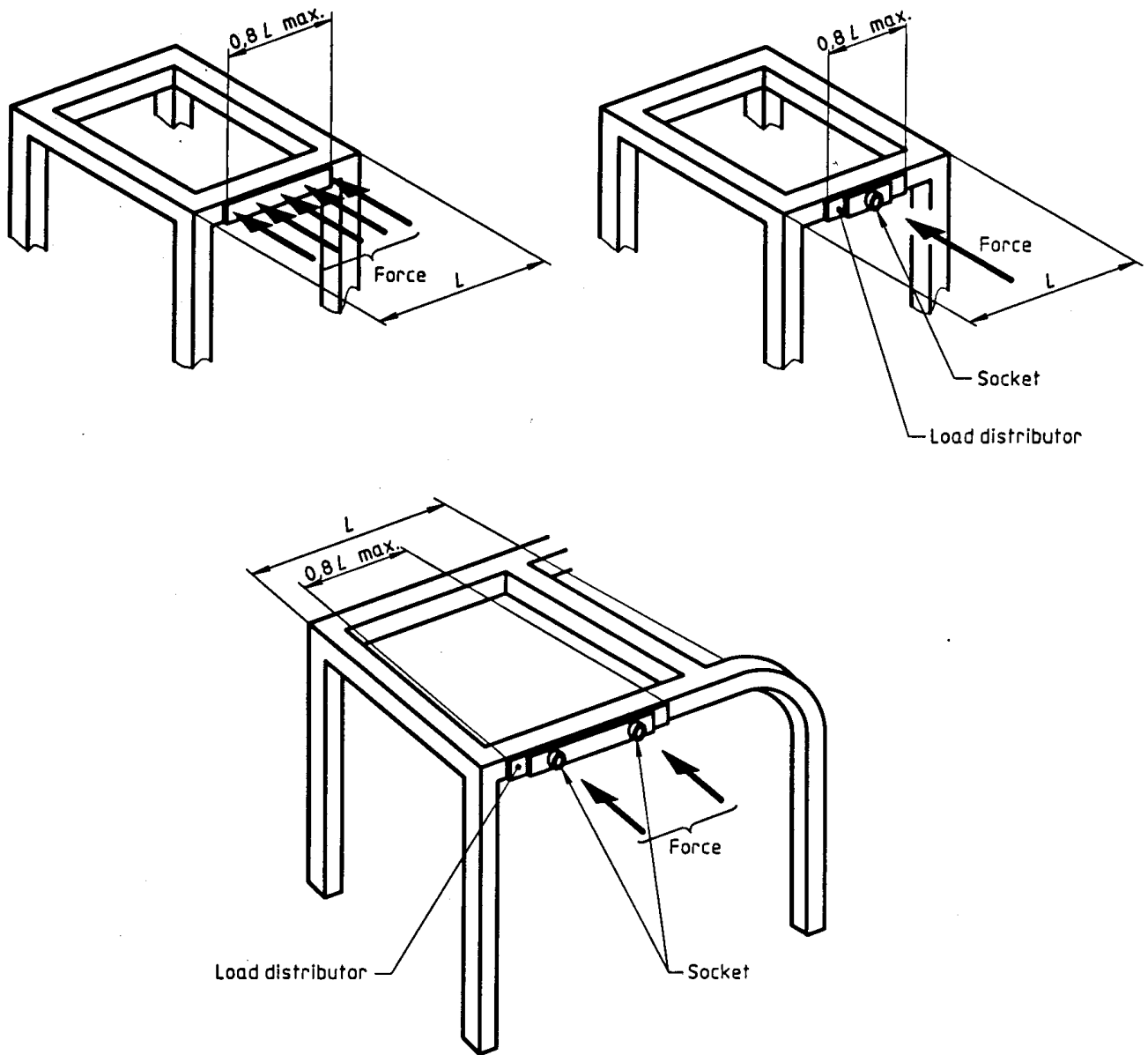

Figure 8.12.b Rear roll bar frame

Figures 8.12

**Position of beam for front crushing test
when full crushing force not sustained in front**



Load distributor and sockets are to prevent local penetration and to hold end load-generating device

Figures 8.13 and 8.14

**Structure with four-post system
Load-distribution devices, side loading**

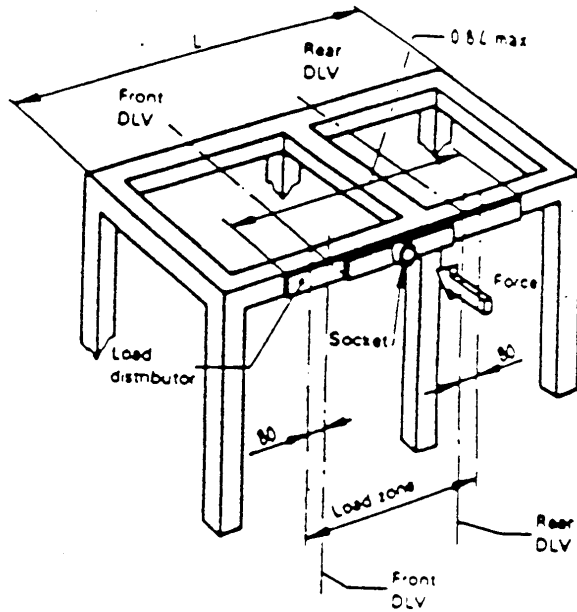

Load distributor and socket are to prevent penetration and to hold end load generating device

Figure 8.15

**Structure with more than a four-post system
Load-distribution device, side loading**

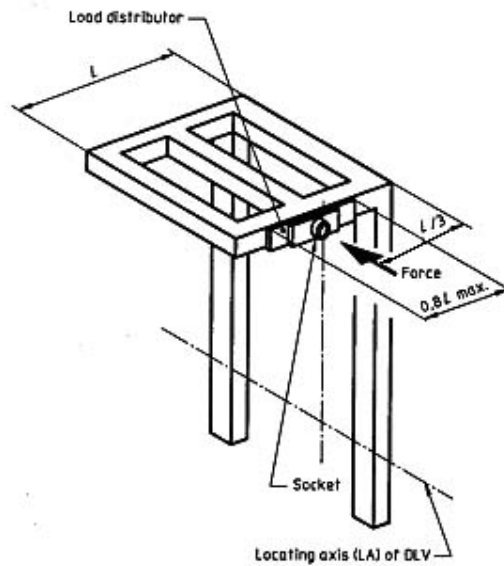

Load distributor and socket are to prevent penetration and to hold end load generating device

Figure 8.16

**Structure with two-post system
Load-distribution device, side loading**

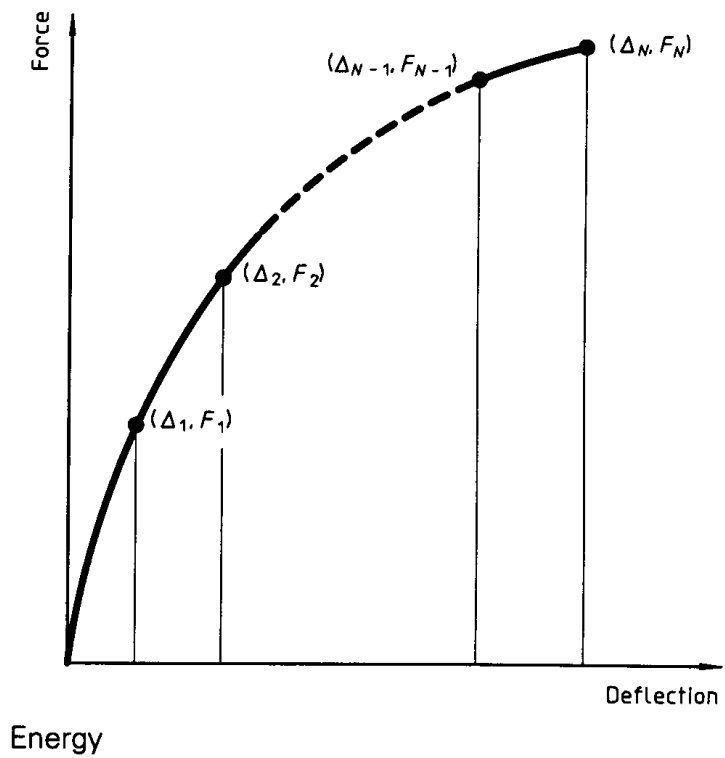

$$U = \frac{\Delta_1 F_1}{2} + (\Delta_2 - \Delta_1) \frac{F_1 + F_2}{2} + \dots$$

$$+ (\Delta_N - \Delta_{N-1}) \frac{F_{N-1} + F_N}{2}$$

To obtain the energy in joules, divide the area beneath the force-deflection curve by 1000.

Figure 8.17

Force-deflection curve for loading tests

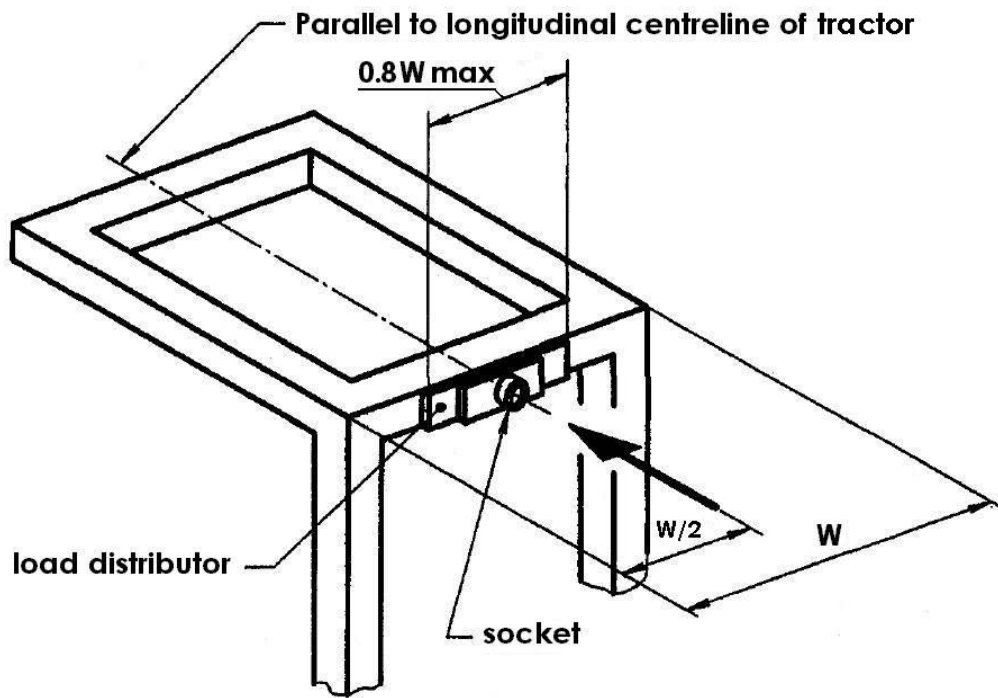
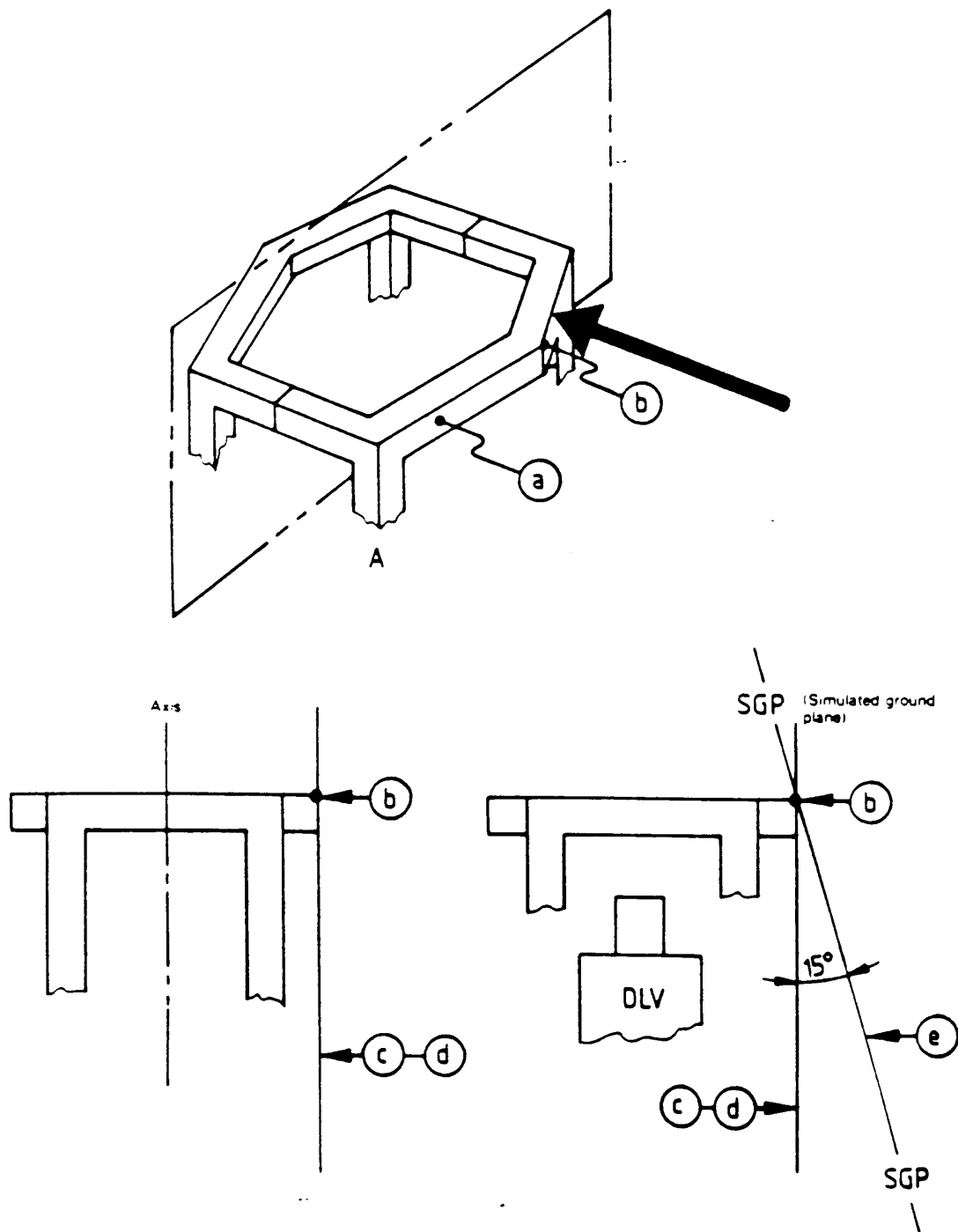

Figure 8.18

Longitudinal load application point



Note: See paragraph 1.11 for the meaning of a to e.

Figure 8.19

Deflection-limiting volume (DLV) application - determination of the lateral simulated ground plane (SGP)

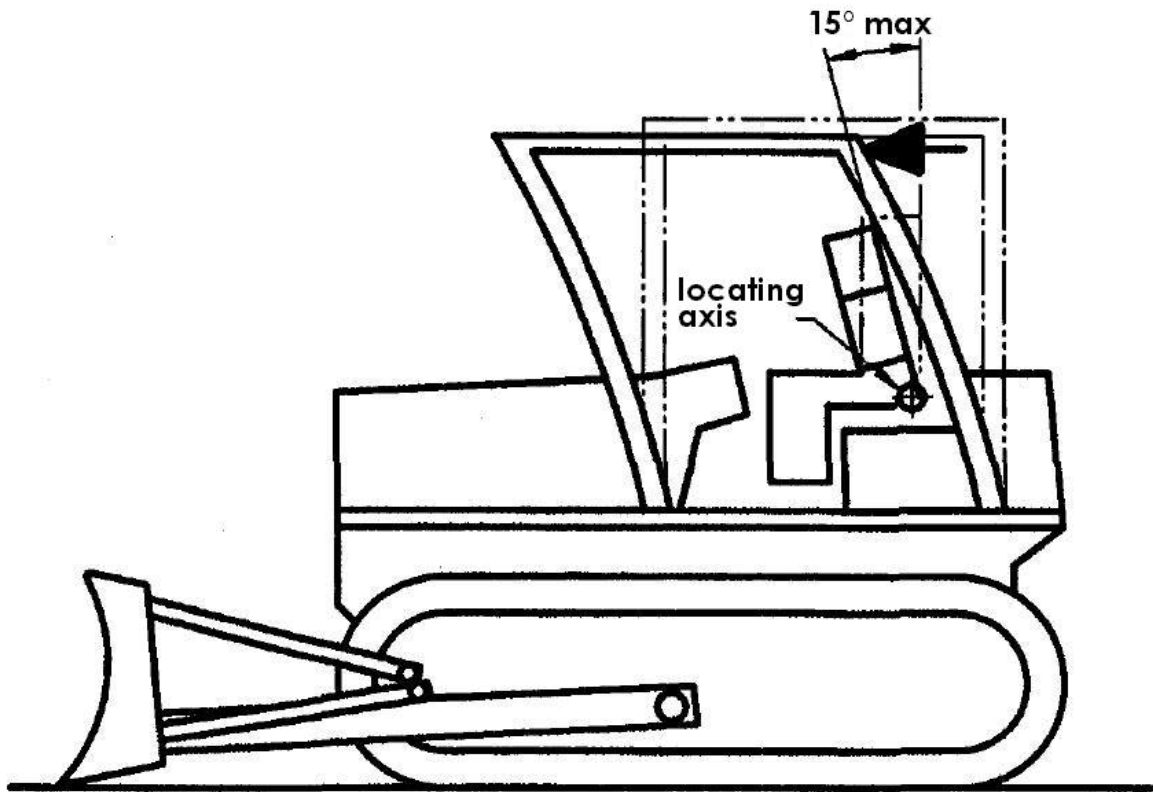

Figure 8.20

Allowable rotation of upper DLV about locating axis (LA)

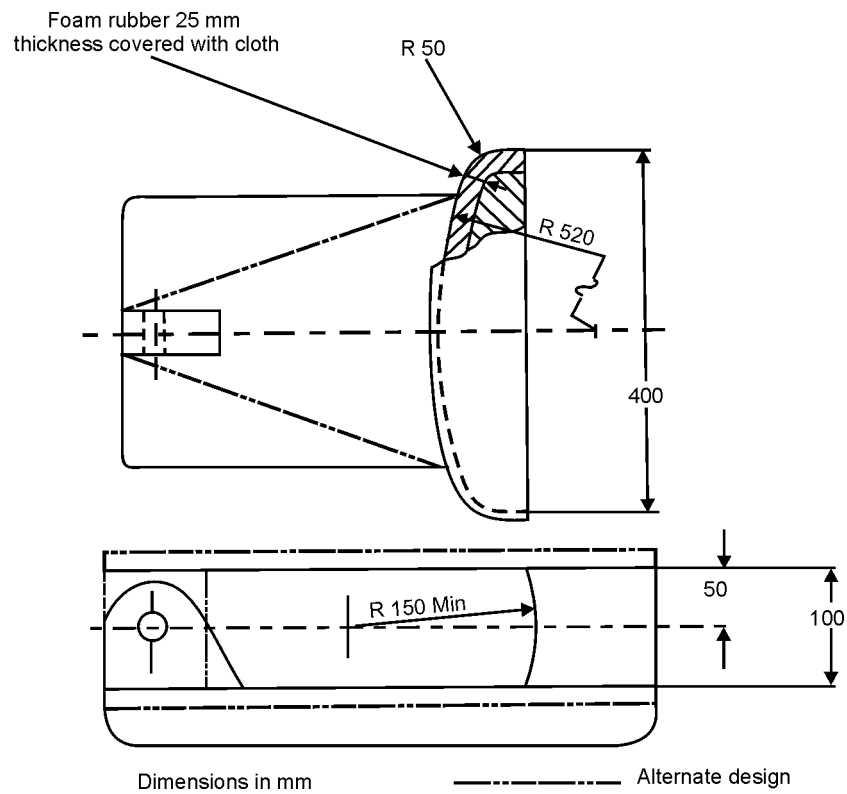

Figure 8.21

The load application device

Note: The dimensions not shown are optional to satisfy the test facility and do not influence the test results

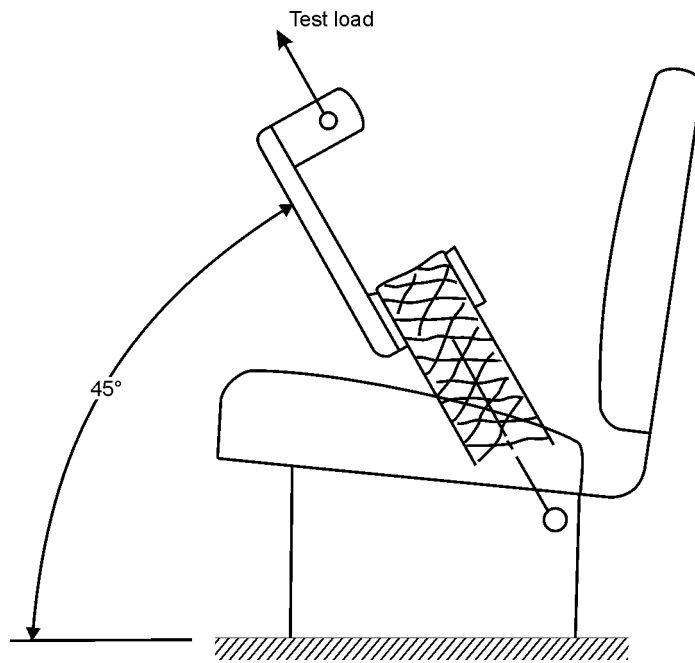

Figure 8.22

Load application in the upward and forward direction

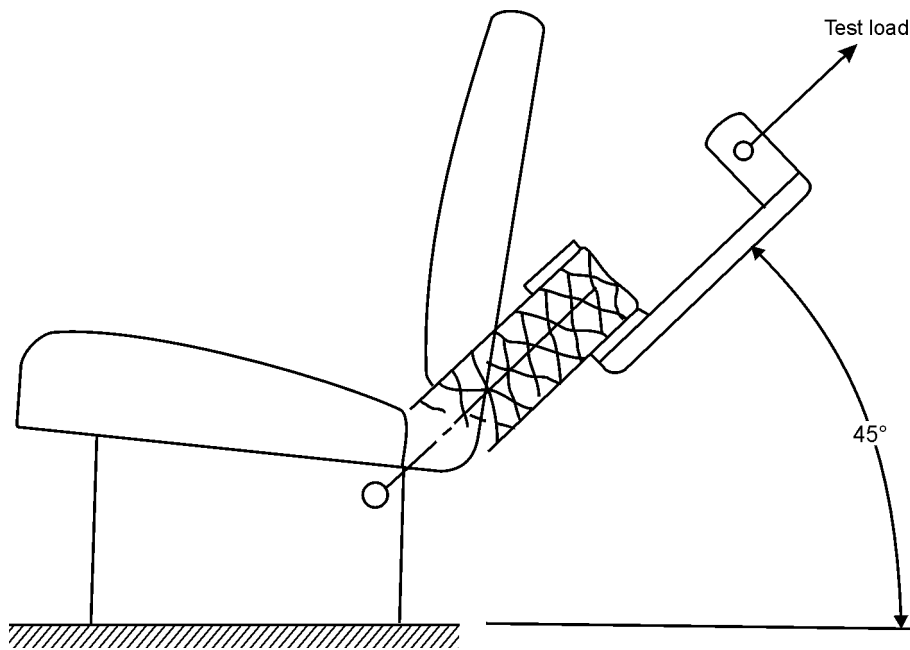

Figure 8.23

Load application in the upward and rearward direction

SPECIMEN TEST REPORT

Note: Units shown below, which appear in ISO 80000-1:2009/Cor.1:2011, shall be stated and followed by national units in parentheses, if necessary.

- Protective structure manufacturer's name and address:
- Submitted for test by:

- Make of the protective structure:
- Model of the protective structure:
- Type of the protective structure: *Cab, Frame, Rear rollbar, Cab with integrated frame, etc.*

- Date, location of test and Code version:

1. SPECIFICATIONS OF TEST TRACTOR

1.1 Identification of tractor to which the protective structure is fitted for the test

- 1.1.1
- Make of the tractor: (*)
 - Model (trade name):
 - Type: *rubber or steel tracks;*

(*) possibly different from tractor manufacturer's name

- 1.1.2 Numbers
- 1st Serial No. or prototype:
 - Serial No.:

1.2 Maximum mass recommended by the tractor manufacturer: kg

1.3 Track: mm

1.4 Dimensions of tracks: mm

1.5 Tractor seat:

- Tractor with a reversible driver's position (reversible seat and steering wheel): Yes / No
- Make/ type/ model of seat:
- Make/ type/ model of optional seat(s)
and position(s) of the seat index point (SIP):
 - (description of seat 1 and SIP position)
 - (description of seat 2 and SIP position)
 - (description of seat _ and SIP position)
- Seat belt anchorage: Type
- Seat mounting on the tractor: Type
- Other seat components: Type

- Seat operating position in the test: Description

Masses used for calculating the loads

Seat	Make/Model/Type
COMPONENTS	MASS (kg)
Driver seat	
Seat belt assembly	
Other seat components	
Total	

2. SPECIFICATIONS OF PROTECTIVE STRUCTURE

2.1 Photographs from side and rear showing mounting details including mudguards

2.2 General arrangement drawing of the side and the rear of the structure including position of the seat index points (SIP), details of mountings and position of the front part of the tractor capable of supporting the tractor when overturned (if necessary). The main dimensions must figure on the drawings, including external dimensions of tractor with protective structure fitted and main interior dimensions.

2.3 Brief description of the protective structure comprising:

- type of construction;
- details of mountings;
- details of cladding and padding;
- details of the front part of the tractor capable of supporting the tractor when overturned (if necessary)
- means of access and escape;
- additional frame: Yes/No

2.4 Tilttable/not tilttable structure

-- Tilttable / not tilttable (*)

If it is necessary to tilt with any tools, this should be stated as follows:

-- Tilttable with tools/ tilttable without tools (*)

-- Folding/ not folding (*)

If it is necessary to fold with any tools, this should be stated as follows:

-- Folding with tools/ folding without tools (*)

(*) *delete as appropriate*

2.5 Dimensions

Dimensions should be measured with seatpan and backrest loaded and adjusted according to Definition 1.8 of the Code.

2.5.1	Height of roof members above the seat index point:	mm
2.5.2	Height of roof members above the tractor footplate:	mm
2.5.3	Interior width of the protective structure 900 mm above the seat index point:	mm
2.5.4	Interior width of the protective structure above the seat index point at the level of centre of the steering wheel or of the segment connecting mid-points of handles of command hand levers:	mm
2.5.5	Distance from the centre of the steering wheel or from the middle of the segment connecting mid-points of handles of command hand levers to the right-hand side of the protective structure:	mm
2.5.6	Distance from the centre of the steering wheel or from the middle of the segment connecting mid-points of handles of command hand levers to the left-hand side of the protective structure:	mm
2.5.7	Minimum distance from the steering wheel rim or control hand levers to the protective structure:	mm
2.5.8	Horizontal distance from the seat index point to the rear of the protective structure at a height of 900 mm above the seat index point:	mm
2.5.9	Position (with reference to the rear axle) of the front part of tractor capable of supporting the tractor when overturned:	
	horizontal distance	mm
	vertical distance	mm

2.6 Details of materials used in the construction of the protective structure and steel specifications

Steel specifications shall be in conformity with ISO 630-1,2,3,4:2011-2012.

2.6.1	Main frame: (parts - material - sizes) <ul style="list-style-type: none"> • Is steel rimmed, semi-killed or killed?: • steel standard and reference: 	
2.6.2	Mountings: <ul style="list-style-type: none"> • Is steel rimmed, semi-killed or killed?: • steel standard and reference: 	(parts - material - sizes)
2.6.3	Assembly and mounting bolts:	(parts - sizes)

- 2.6.4 Roof : (parts - material - sizes)
- 2.6.5 Cladding: (parts - material - sizes)
- 2.6.6 Glass: (type - grade - sizes)
- 2.6.7 Front part of the tractor capable of supporting the tractor when overturned (if necessary) (parts - material - sizes)

2.7. Details of tractor manufacturer's reinforcements on original parts

3. TEST RESULTS

3.1 Side-load, vertical crushing and longitudinal load tests

3.1.1 Condition of tests

- Loading tests were made:

- to the side right/left
- longitudinally at the back/front

- Mass used for calculating loading energies and crushing forces: kg

- Energies and forces applied:

- side: kJ
- energy absorbed: kJ
- crushing force: kN
- back/front kN
- crushing force applied to the rear frame for track-laying tractors with an unballasted mass lower than 5000 kg, fitted with front-mounted protective structure having a two-post system: kN

3.1.2 Permanent deflections of the extremities of the protective structure measured after the series of tests:

- Back (forwards/backwards):

- left-hand: mm
- right-hand: mm

- Front (forwards/backwards):

- left-hand: mm
- right-hand: mm

- Sideways (to the left/to the right):

- front: mm

- rear: mm
- Top (downwards/upwards):
 - rear: left-hand: mm
 - right-hand: mm
 - front: left-hand: mm
 - right-hand: mm

Statement:

The acceptance conditions relative to the protection of the deflection-limiting volume are fulfilled. This structure is a roll-over protective structure in accordance with the Codes.

3.1.3 Curves

A copy of the force/deflection curves derived during the tests shall be included.

3.2 Cold weather performance (resistance to brittle fracture)

Method used to identify resistance to brittle fracture at reduced temperature:

.

Steel specifications shall be in conformity with ISO 630-1,2,3,4:2011-2012.

Steel specification: (reference and relevant standard)

3.3 Seat belt anchorage performance

3.3.1 Loading in the forward and upward direction

Driver seat	Make/Model/Type	
GRAVITY FORCE ($F_g = \text{seat mass} \times 9.81$) N	REQUIRED FORCE ($4450 + 4 F_g$) N	APPLIED FORCE N

3.3.2. Loading in the rearward and upward direction

Driver seat	Make/Model/Type	
GRAVITY FORCE ($F_g = \text{seat mass} \times 9.81$) N	REQUIRED FORCE ($2225 + 2 F_g$) N	APPLIED FORCE N

3.3.3 Curves, drawings and photos

A copy of the force/deflection curves derived during the tests shall be included.

Drawings and/or photos of the seat mounting and seat belt anchorages have to be added.

Statement (if necessary):

The testing station certifies that the tested seat is the worst variant among the seats listed below that are identical regarding the seatbelt anchorage performance test.

Statement:

During the test, no structural failure or release of seat, seat adjuster mechanism or other locking service occurred. The seat and safety belt anchorage tested fulfil the requirement of the OECD procedure.

3.4 Tractor(s) to which the protective structure is fitted

OECD Approval Number:						
Make	Model	Type	Other specifications	Maximum mass	Structure tiltable	Track
			<i>where applicable</i>	kg	<i>Yes/No</i>	mm

SPECIMEN TECHNICAL EXTENSION REPORT

Note: Units shown below, which appear in ISO 80000-1:2009/Cor.1:2011, shall be stated and followed by national units in parentheses, if necessary.

- Protective structure manufacturer's name and address:
- Submission for extension by:

- Make of the protective structure:
- Model of the protective structure:
- Type of the protective structure: *Cab, Frame, Rear rollbar, Cab with integrated frame, etc.*

- Date, location of extension and Code version:

- Reference of the original test:
- Approval number and date of the original test report:

- Statement giving the reasons of the extension and explaining the procedure chosen (e.g. extension with validation test):

Depending on the case some of the following paragraphs may be omitted if their content is identical to the one of the original test report. It is only necessary to highlight the differences between the tractor and protective structure described in the original test report and the one for which the extension has been required.

1. SPECIFICATION OF TEST TRACTOR

1.1 Identification of tractor to which the protective structure is fitted for the test

- 1.1.1 - Make of the tractor: (*)
- Model (trade name):
- Type: *rubber or steel tracks;*

(*) *possibly different from tractor manufacturer's name*

- 1.1.2 Numbers
- 1st Serial No. or prototype:
- Serial No.:

1.2 **Maximum mass recommended by the tractor manufacturer** kg

1.3 **Tracks:** mm

1.4 **Dimensions of tracks:** mm

1.5 Tractor seat

- Tractor with a reversible driver's position (reversible seat and steering wheel): Yes / No

- Make/ type/ model of seat:
- Make/ type/ model of optional seat(s)
and position(s) of the seat index point (SIP):
 - (description of seat 1 and SIP position)
 - (description of seat 2 and SIP position)
 - (description of seat __ and SIP position)
- Seat belt anchorage: Type
- Seat mounting on the tractor: Type
- Other seat components: Type
- Seat operating position in the test: Description

Masses used for calculating the loads

Seat	Make/Model/Type
COMPONENTS	MASS (kg)
Driver seat	
Seat belt assembly	
Other seat components	
Total	

2. SPECIFICATION OF PROTECTIVE STRUCTURE

2.1 Photographs from side and rear showing mounting details including mudguards

2.2 General arrangement drawing of the side and the rear of the structure including position of the seat index points (SIP), details of mountings and position of the part of front of the tractor capable of supporting the tractor when overturned (if necessary). The main dimensions must figure on the drawings, including external dimensions of tractor with protective structure fitted and main interior dimensions.

2.3 Brief description of the protective structure comprising:

- type of construction;
- details of mountings;
- details of cladding and padding;
- details of the front part of the tractor capable of supporting the tractor when overturned (if necessary);
- means of access and escape;
- additional frame:

Yes / No

2.4 Tiltable or not tiltable/ Folding or not folding structure

-- Tiltable / not tiltable (*)

If it is necessary to tilt with any tools, this should be stated as follows:

-- Tiltable with tools/ tiltable without tools (*)

-- Folding/ not folding (*)

If it is necessary to fold with any tools, this should be stated as follows:

-- Folding with tools/ folding without tools (*)

(*) delete as appropriate

2.5 Dimensions

Dimensions should be measured with seatpan and backrest loaded and adjusted according to Definition 1.8 of the Code.

2.5.1	Height of roof members above the seat index point:	mm
2.5.2	Height of roof members above the tractor footplate:	mm
2.5.3	Interior width of the protective structure 900 mm above the seat index point:	mm
2.5.4	Interior width of the protective structure above the seat index point at the level of centre of the steering wheel or of the segment connecting mid-points of handles of command hand levers:	mm
2.5.5	Distance from the centre of the steering wheel or from the middle of the segment connecting mid-points of handles of command hand levers to the right-hand side of the protective structure:	mm
2.5.6	Distance from the centre of the steering wheel or from the middle of the segment connecting mid-points of handles of command hand levers to the left-hand side of the protective structure:	mm
2.5.7	Minimum distance from the steering wheel rim or control hand levers to the protective structure:	mm
2.5.8	Horizontal distance from the seat index point to the rear of the protective structure at a height of 900 mm above the seat index point:	mm
2.5.9	Position (with reference to the rear axle) of the front part of tractor capable of supporting the tractor when overturned:	
	horizontal distance	mm
	vertical distance	mm

2.6 Details of materials used in the construction of the protective structure and specifications of steels used

Steel specifications shall be in conformity with ISO 630-1,2,3,4:2011-2012.

- | | | |
|-------|---|----------------------------|
| 2.6.1 | Main frame: | (parts - material - sizes) |
| | <ul style="list-style-type: none"> • Is steel rimmed, semi-killed or killed?: • steel standard and reference: | |
| 2.6.2 | Mountings: | (parts - material - sizes) |
| | <ul style="list-style-type: none"> • Is steel rimmed, semi-killed or killed?: • steel standard and reference: | |
| 2.6.3 | Assembly and mounting bolts: | (parts - sizes) |
| 2.6.4 | Roof : | (parts - material - sizes) |
| 2.6.5 | Cladding: | (parts - material - sizes) |
| 2.6.6 | Glass: | (type - grade - sizes) |
| 2.6.7 | Front part of the tractor capable of supporting the tractor when overturned (if necessary) | (parts - material - sizes) |

2.7. Details of tractor manufacturer's reinforcements on original parts

3. TEST RESULTS (in case of a validation test)

3.1 Side-load, vertical crushing and longitudinal load tests

3.1.1 Condition of tests

- Loading tests were made:

- to the side right/left
- longitudinally at the back/front

- Mass used for calculating loading energies and crushing forces: kg

- Energies and forces applied:

- side: kJ
- energy absorbed: kJ
- crushing force: kN
- back/front kN
- crushing force applied to the rear frame for track-laying tractors with an unballasted mass lower than 5000 kg, fitted with front-mounted protective structure having a two-post system: kN

3.1.2 Permanent deflections measured after the tests

3.1.2.1 Permanent deflections of the extremities of the protective structure measured after the series of tests:

- Back (forwards/backwards):
 - left-hand: mm
 - right-hand: mm
- Front (forwards/backwards):
 - left-hand: mm
 - right-hand: mm
- Sideways (to the left/to the right):
 - front: mm
 - rear: mm
- Top (downwards/upwards):
 - rear: left-hand: mm
 - right-hand: mm
 - front: left-hand: mm
 - right-hand: mm

3.1.2.2 Difference between total instantaneous deflection and residual deflection during sideways loading test (elastic deflection): mm

Statement:

The difference between the original tested models and the models for which the extension has been required are:

- ...

-

The results of the validation test fulfil the $\pm 7\%$ conditions (if relevant)

The test station has checked the modifications and certifies that the effect of these modifications does not affect the results on the strength of the protective structure.

The acceptance conditions relative to the protection of deflection-limiting volume are fulfilled. The structure is a roll-over protective structure in accordance with the Code.

3.1.3 Curves

A copy of the force/deflection curves derived during the tests shall be included (in the case of a validation test).

	Deflection measured when required energy level has been reached			Force measured when required energy level has been reached		
	original test mm	validation test mm	relative deviation %	original test kN	validation test kN	relative deviation %
Longitudinal loading test						
Lateral loading test						

If a horizontal overload test was required, the reason for the overload shall be described and the copy of additional force/deflection curves obtained during overload shall be included.

3.2 Cold weather performance (resistance to brittle fracture)

Method used to identify resistance to brittle fracture at reduced temperature:

·
·
·

Steel specifications shall be in conformity with ISO 630-1,2,3,4:2011-2012.

Steel specification: (reference and relevant standard)

3.3 Seat belt anchorage performance

3.3.1 Loading in the forward and upward direction

Driver seat	Make/Model/Type	
GRAVITY FORCE ($F_g = \text{seat mass} \times 9.81$) N	REQUIRED FORCE ($4450 + 4 F_g$) N	APPLIED FORCE N

3.3.2. Loading in the rearward and upward direction

Driver seat	Make/Model/Type	
GRAVITY FORCE ($F_g = \text{seat mass} \times 9.81$) N	REQUIRED FORCE ($2225 + 2 F_g$) N	APPLIED FORCE N

3.3.3 Curves, drawings and photos

A copy of the force/deflection curves derived during the tests shall be included.

Drawings and/or photos of the seat mounting and seat belt anchorages have to be added.

Statement:

During the test, no structural failure or release of seat, seat adjuster mechanism or other locking service occurred. The seat and safety belt anchorage tested fulfil the requirement of the OECD procedure.

3.4 Tractor(s) to which the protective structure is fitted

OECD Approval Number:						
Make	Model	Type	Other specifications	Maximum mass	Structure tiltable	Track
			<i>where applicable</i>	kg	<i>Yes/No</i>	mm

SPECIMEN ADMINISTRATIVE EXTENSION REPORT

Note: Units shown below, which appear in ISO 80000-1:2009/Cor.1:2011, shall be stated and followed by national units in parentheses, if necessary.

- Submitted for extension by:
- Date, location of extension and Code version:

- Reference of the original test:
- Approval number and date of the original test:

- Statement giving the reasons of the extension and explaining the procedure chosen.

1. Specification of the protective structure

- Frame or Cab:
- Manufacturer:
- Make:
- Model:
- Type:
- Serial Number from which modification applies:

2. Denomination of tractor(s) to which the protective structure is fitted

OECD Approval Number:						
Make	Model	Type	Other specifications	Maximum mass	Structure tiltable	Track
			<i>where applicable</i>	kg	<i>Yes/No</i>	mm

3. Details of modifications

Since the original test report the following modifications have been made:

4. Statement

The modifications do not to affect the results of the original test.

The original test report therefore applies.

NEW AMENDMENTS IN THE 2024 EDITION OF THE OECD TRACTOR CODES

Background

The 2024 edition of the Tractor Codes, released on 1 February 2024, incorporates several amendments as approved by the 2023 Annual Meeting.

Amendments:

General texts

Increase of the Basic fee to 4,000 EUR

Code 2

No change

Code 3

No change

Code 4

No change

Code 5

No change

Code 6

No change

Code 7

No change

Code 8

No Change

Code 9

No change

Code 10

No change