

CODE 10

**OECD STANDARD CODE FOR THE OFFICIAL TESTING OF
FALLING OBJECT PROTECTIVE STRUCTURES ON AGRICULTURAL
AND FORESTRY TRACTORS**

TABLE OF CONTENTS

INTRODUCTION	3
1. DEFINITIONS	3
1.1 Agricultural and forestry tractors	3
1.2 Falling Object Protective Structure (FOPS)	3
1.3 Safety zone	3
1.4 Permissible measurement tolerances	4
2. FIELD OF APPLICATION.....	4
3. RULES AND DIRECTIONS	4
3.1 General regulations.....	4
3.2 Apparatus and procedures	5
3.3 Performance requirements.....	7
3.4 Extension to other tractor models.....	8
3.5 Labelling.....	9
3.6 Cold weather performance of protective structures.....	9
SPECIMEN TEST REPORT	15
1. SPECIFICATION OF TEST TRACTOR.....	15
2. SPECIFICATION OF PROTECTIVE STRUCTURE	16
3. TEST RESULTS	17
SPECIMEN TECHNICAL EXTENSION REPORT	19
1. SPECIFICATION OF TEST TRACTOR.....	19
2. SPECIFICATION OF PROTECTIVE STRUCTURE.....	20
SPECIMEN ADMINISTRATIVE EXTENSION REPORT.....	22
ANNEX I CLEARANCE ZONE REFERRED TO THE SEAT REFERENCE POINT	23
INTRODUCTION	24
1. DEFINITIONS.....	24
1.2 Determination of Seat Reference Point; Seat location and adjustment for test.....	24
1.3 Safety zone	24

CODE 10

OECD STANDARD CODE FOR THE OFFICIAL TESTING OF FALLING OBJECT PROTECTIVE STRUCTURES ON AGRICULTURAL AND FORESTRY TRACTORS

INTRODUCTION

The FOPS testing procedure considered in this Code refers to the tractor used in its traditional agricultural tasks. However, it is reasonable to consider that a specific use of the tractor, such as dedicated forestry applications, for which generally the tractor has to be properly equipped, can need FOPS tests at higher levels of energy. These FOPS tests can be carried out using other appropriate test methods.

1. DEFINITIONS

1.1 *Agricultural and forestry tractors*

Self-propelled wheeled vehicles, having at least two axles, or with tracks, designed to carry out the following operations, primarily for agricultural and forestry purposes:

- to pull trailers;
- to carry, pull or propel agricultural and forestry tools or machinery and, where necessary, supply power to operate them with the tractor in motion or stationary.

1.2 *Falling Object Protective Structure (FOPS)*

Assembly providing reasonable overhead protection to an operator in driving position from falling objects.

1.3 *Safety zone*

1.3.1 Clearance zone

For tractors equipped with ROPS tested in accordance with Codes 3, 4, 6 and 7 the safety zone shall comply with the specifications of the Clearance Zone as described in point 1.6 of each of these codes.

1.3.2 Deflection-Limiting Volume (DLV)

For tractors equipped with ROPS tested in accordance with Code 8 the safety zone shall comply with the Deflection-Limiting Volume (DLV), as described in ISO 3164:2013.

In the event the tractor has a reversible driver's position (reversible seat and steering wheel), the safety zone shall be the combined envelope of the two DLVs defined by the two different positions of the steering wheel and the seat.

1.3.3 Top area of the safety zone

Respectively the top plane of the DLV or the surface defined by points I₁, A₁, B₁, C₁, C₂, B₂, A₂, I₂ of clearance zone for Codes 3 and 4; the plane described in 1.6.2.3 and 1.6.2.4 of Code 6; and the surface defined by points H₁, A₁, B₁, C₁, C₂, B₂, A₂, H₂ for Code 7 .

1.4 Permissible measurement tolerances

Distance $\pm 5\%$ of maximum deflection measured, or ± 1 mm
Mass $\pm 0.5\%$

2. FIELD OF APPLICATION

2.1 This OECD Standard Code is applicable to agricultural and forestry tractors having at least two axles for pneumatic tyred wheels or having tracks instead of wheels.

2.2 This Code establishes test procedures and performance requirements for those tractors exposed to potential hazards of falling objects encountered carrying out some agricultural tasks during their normal operation.

3. RULES AND DIRECTIONS

3.1 General regulations

3.1.1 The protective structure may be manufactured either by the tractor manufacturer or by an independent firm. In either case the test is only valid for the model of tractor on which the test is carried out. The protective structure must be retested for each model of tractor to which it is to be fitted. However, testing stations may certify that the strength tests are also valid for tractor models derived from the original model by modifications to the engine, transmission and steering and front suspension (*see below 3.4: Extension to other tractor models*). On the other hand, more than one protective structure may be tested for any one model of tractor.

3.1.2 The protective structure submitted for test shall include at least all components which transfer loading from the impact location of the drop test object to the safety zone. The protective structure submitted for test shall be either (i) rigidly attached to the test bench at its normal mounting locations (*see Figure 10.3 – Minimum Test Configuration*), or (ii) attached to the tractor chassis in the normal manner, by means any brackets, mountings or suspension components used in normal production and other parts of the tractor that may be affected by loads imposed by the protective structure (*see Figures 10.4(a) & 10.4(b)*). The vehicle chassis shall be mounted rigidly to the test bay floor.

3.1.3 A protective structure may be designed solely to protect the driver in the event of an object falling. Onto this structure it may be possible to fit weather protection for the driver, of a more or less temporary nature. The driver will usually remove this in warm weather. There are protective structures, however, in which the cladding is permanent and warm weather ventilation provided by windows or flaps. As the cladding may add to the strength of the structure and if removable may well be absent when an accident occurs, all parts that can be so taken away by the driver shall be removed for the purpose of the test. Doors and windows that can be opened shall be either removed or fixed in the open position for the test, so that they do not add to the strength of the protective structure.

3.1.3.1 In case of an openable roof hatch on the vertical projection of the safety zone, on request of the manufacturer, under his responsibility and in accordance with his instructions, the test can be either performed with the roof hatch:

- in the closed - locked position

or

- in the open position

or

- removed;

In any case, the requirements of paragraph 3.3 shall be fulfilled.

A description of the test condition shall be stated in the test report.

Throughout the remainder of these rules, reference will only be made to testing the protective structure. It must be understood that this includes cladding not of a temporary nature.

A description of any temporary cladding supplied is to be included in the specifications. All glass or similar brittle material shall be removed prior to the test. Tractor and protective structure components which might sustain needless damage during the test and which do not affect the strength of the protective structure or its dimensions may be removed prior to the test if the manufacturer wishes. No repairs or adjustment may be carried out during the test. Several identical samples can be provided by the manufacturer if several drop tests are required.

3.1.4 Should the same structure be used for FOPS and ROPS evaluations the FOPS test shall precede the ROPS tests (according to Codes 3, 4, 6, 7 or 8), the removal of impact dents or replacement of the FOPS cover is permitted.

3.2 Apparatus and procedures

3.2.1 Apparatus

3.2.1.1 Drop test object

The drop test object shall be a spherical object dropped from a height sufficient to develop the energy of 1365 J, the drop height being defined as a function of its mass. The test object, whose impact surface shall have properties to protect against deformation during testing, shall be a solid steel or ductile iron sphere with a typical mass of 45 ± 2 kg and a diameter between 200 and 250 mm (Table 10.1).

ENERGY LEVEL (J)	SAFETY ZONE	DROP OBJECT	DIMENSIONS (mm)	MASS (kg)
1365	Clearance zone*	Sphere	$200 \leq \text{Diameter} \leq 250$	45 ± 2
1365	DLV**	Sphere	$200 \leq \text{Diameter} \leq 250$	45 ± 2

Table 10.1

Energy level, safety zone and drop test object selection

* For tractors the ROPS of which is to be tested according to Codes 3, 4, 6 or 7.

** For tractors the ROPS of which is to be tested according to Code 8.

Test Facility apparatus is also required to provide:

3.2.1.2 Means of raising the drop test object to the required height.

3.2.1.3 Means of releasing the drop test object so that it drops without restraint.

3.2.1.4 Surface of such firmness that it is not penetrated by the machine or test bed under the loading of the drop test.

3.2.1.5 Means of determining whether the FOPS enters the safety zone during the drop test. This may be either of the following:

- a safety zone template, placed upright, made of a material which will indicate any penetration by the FOPS; grease or other suitable material may be put on the lower surface of the FOPS cover to indicate such penetration;
- a dynamic instrumentation system of sufficient frequency response to indicate the expected deflection of the FOPS with respect to the safety zone.

3.2.1.6 Safety zone requirements:

The safety zone template, if any, shall be fixed firmly to the same part of the tractor as the operator's seat and shall remain there during the entire formal test period.

3.2.2 Procedure

The drop test procedure shall consist of the following operations, in the order listed.

3.2.2.1 Place the drop test object (3.2.1.1) on the top of the FOPS, at the location designated in 3.2.2.2.

3.2.2.2 When the safety zone is represented by the clearance zone the point of impact shall be at a location which is within the vertical projection of the clearance zone and is furthest removed from major structural members (Figure 10.1).

When the safety zone is represented by the DLV, the impact location shall be entirely within the vertical projection of the safety zone, in that volume's upright position, on to the top of the FOPS. It is intended that the selection of impact location shall include at least one within the vertical projection of the top plane area of the safety zone.

Two cases have to be considered:

3.2.2.2.1 Case 1: Where major, upper, horizontal members of the FOPS do not enter the vertical projection of the safety zone on to the top of the FOPS.

The impact location shall be as close as possible to the centroid of the upper FOPS structure (Figure 10.2 – Case 1).

3.2.2.2.2 Case 2: Where major, upper, horizontal members of the FOPS enter the vertical projection of the safety zone on to the top of the FOPS.

When the covering material of all the surface areas above the safety zone is of uniform thickness, the impact location shall be in the surface of greatest area, this being the largest section of vertical projected area of the safety zone which does not include major, upper, horizontal members. The impact location shall be at that point, within the surface of greatest area, which has the least possible distance from the centroid of the top of the FOPS (Figure 10.2 – Case 2).

3.2.2.3 Irrespective of whether the safety zone is represented by the clearance zone or the DLV, where different materials or different thicknesses are used in different areas above the safety zone, each area shall be subjected to a drop test. If several drop tests are required, several identical samples of the FOPS (or parts of it) could be provided by the manufacturer (one for each drop test). If design features, such as openings for windows or equipment, or variations in cover material or thickness, indicate a more vulnerable location within the vertical projection of the safety zone, the drop location should be adjusted to that location. In addition, if openings in the FOPS cover are intended to be filled with devices or equipment to provide adequate protection, those devices or equipment shall be in place during the drop test.

3.2.2.4 Raise the drop test object vertically to a height above the position indicated in 3.2.2.1 and 3.2.2.2 to develop the energy of 1365 J.

3.2.2.5 Release the drop object so that it falls without restraint onto the FOPS.

3.2.2.6 As it is unlikely that the free fall will result in the drop test object hitting at the location as specified in 3.2.2.1 and 3.2.2.2, the following limits are placed on deviations.

3.2.2.7 The impact point of the drop test object shall be entirely within a circle of 100 mm radius whose centre shall coincide with the vertical centre line of the drop test object as positioned according to 3.2.2.1 and 3.2.2.2).

3.2.2.8 There is no limitation on location or attitude of subsequent impacts due to rebound.

3.3 Performance requirements

The safety zone shall not be entered into by any part of the protective structure under the first or subsequent impacts of the drop test object. Should the drop test object penetrate the FOPS, it shall be considered to have failed that test.

Note 1: In the case of multilayer protective structure all the layers including the innermost layer shall be considered.

Note 2: The drop test object is considered to have penetrated the protective structure when at least half of the sphere volume has penetrated the innermost layer.

The FOPS shall completely cover and overlap the vertical projection of the safety zone.

If the tractor is to be equipped with a FOPS fitted on an approved ROPS, the testing station which performed the ROPS test will normally be the only one allowed to carry out the FOPS test and to require for the approval.

3.4 Extension to other tractor models

3.4.1 Administrative extension

If there are changes in the make, denomination or marketing features of the tractor or protective structure tested or listed in the original test report, the testing station that has carried out the original test can issue an “administrative extension report”. This extension report shall contain a reference to the original test report.

3.4.2 Technical extension

If the test was carried out with the minimum components required (*as in Figure 10.3*), then the testing station that has carried out the original test can issue a “technical extension report” in the following cases: [see 3.4.2.1]

If the test was carried out including the attachments / mountings of the protective structure to the tractor/chassis (*as in Figure 10.4*), then when technical modifications occur on the tractor, to the protective structure or to the method of attachment of the protective structure to the vehicle chassis, the testing station that has carried out the original test can issue a “technical extension report” in the following cases: [see 3.4.2.1]

3.4.2.1 Extension of the structural test results to other models of tractors

The impact test needs not to be carried out on each model of tractor, provided that the protective structure and tractor comply with the conditions referred to hereunder 3.4.2.1.1 to 3.4.2.1.3.

3.4.2.1.1 The structure shall be identical to the one tested;

3.4.2.1.2 If the test carried out included the method of attachment to the vehicle chassis, the tractor attachment components/ protective structure mountings shall be identical;

3.4.2.1.3 The position and critical dimensions of the seat in the protective structure and the relative position of the protective structure on the tractor shall be such that the safety zone would have remained within the protection of the deflected structure throughout all tests (this shall be checked by using the same reference of clearance zone as in the original test report, respectively Seat Reference Point [SRP] or Seat Index Point [SIP]¹).

3.4.2.2 Extension of the structural test results to modified models of the protective structure

This procedure has to be followed when the provisions of paragraph 3.4.2.1 are not fulfilled, it shall not be used when the method of attachment of the protective structure to the tractor does not remain of the same principle (e.g. rubber supports replaced by a suspension device):

Modifications having no impact on the results of the initial test (e.g. weld attachment of the mounting plate of an accessory in a non-critical location on the structure), addition of seats with different SRP or SIP

¹ For extension tests to test reports that originally used seat reference point (SRP), the required measurements shall be made with reference to SRP instead of SIP and the use of SRP shall be clearly indicated (see Annex 1).

location in the protective structure (subject to checking that the new safety zone(s) remain(s) within the protection of the deflected structure throughout all tests).

More than one protective structure modifications may be included in a single extension report if they represent different options of the same protective structure. The options not tested shall be described in a specific section of the extension report.

3.4.3 In any case the test report shall contain a reference to the original test report.

3.5 *Labelling*

3.5.1 OECD labelling is optional. If a label is utilised, it shall contain at least the following information:

3.5.1.1 OECD reference;

3.5.1.2 OECD approval number.

3.5.2 The label shall be durable and permanently attached to the protective structure such that it can be easily read and it shall be protected from environmental damage.

3.6 *Cold weather performance of protective structures*

3.6.1 If the protective structure is claimed to have properties resistant to cold weather embrittlement, the manufacturer shall give details that shall be included in the report.

3.6.2 The following requirements and procedures are intended to provide strength and resistance to brittle fracture at reduced temperatures. It is suggested that the following minimum material requirements shall be met in judging the protective structure's suitability at reduced operating temperatures in those countries requiring this additional operating protection:

3.6.2.1 Bolts and nuts used to attach the protective structure to the tractor and used to connect structural parts of the protective structure shall exhibit suitable controlled reduced temperature toughness properties.

3.6.2.2 All welding electrodes used in the fabrication of structural members and mounts shall be compatible with the protective structure material as given in 3.8.2.3 below.

3.6.2.3 Steel materials for structural members of the protective structure shall be of controlled toughness material exhibiting minimum Charpy V-Notch impact requirements as shown in Table 10.2. Steel grade and quality shall be specified in accordance with ISO 630-1,2,3,4:2011-2012.

Steel with an as-rolled thickness less than 2.5 mm and with a carbon content less than 0.2 per cent is considered to meet this requirement.

Structural members of the protective structure made from materials other than steel shall have an impact resistance equivalent to the one required for steel materials

3.6.2.4 When testing the Charpy V-Notch impact energy requirements, the specimen size shall be no less than the largest of the sizes stated in Table 1 that the material will permit.

3.6.2.5 The Charpy V-Notch tests shall be made in accordance with the procedure in ASTM A 370-1979, except for specimen sizes that shall be in accordance with the dimensions given in Table 10.2.

3.6.2.6 Alternatives to this procedure are the use of killed or semi-killed steel for which an adequate specification shall be provided. Steel grade and quality shall be specified in accordance with ISO 630-1,2,3,4:2011-2012.

3.6.2.7 Specimens are to be longitudinal and taken from flat stock, tubular or structural sections before forming or welding for use in the protective structure. Specimens from tubular or structural sections are to be taken from the middle of the side of greatest dimension and shall not include welds.

3.6.2.8 Alternatively, these requirements can be verified by applying the test object impact if all structural members are at, or below, -18°C .

Specimen size	Energy at	Energy at
	- 30 °C	- 20 °C
mm	J	J ^{b)}
10 x 10 ^{a)}	11	27.5
10 x 9	10	25
10 x 8	9.5	24
10 x 7,5 ^{a)}	9.5	24
10 x 7	9	22.5
10 x 6.7	8.5	21
10 x 6	8	20
10 x 5 ^{a)}	7.5	19
10 x 4	7	17.5
10 x 3.5	6	15
10 x 3	6	15
10 x 2.5 ^{a)}	5.5	14

Table 10.2

Impact Energy - Minimum Charpy V-Notch impact energy requirements for protective structure material at specimen temperatures of -20°C and -30°C

- a) Indicates preferred size. Specimen size shall be no less than largest preferred size that the material permits.
- b) The energy requirement at – 20 °C is 2.5 times the value specified for – 30 °C. Other factors affect impact energy strength, i.e. direction of rolling, yield strength, grain orientation and welding. These factors shall be considered when selecting and using steel.

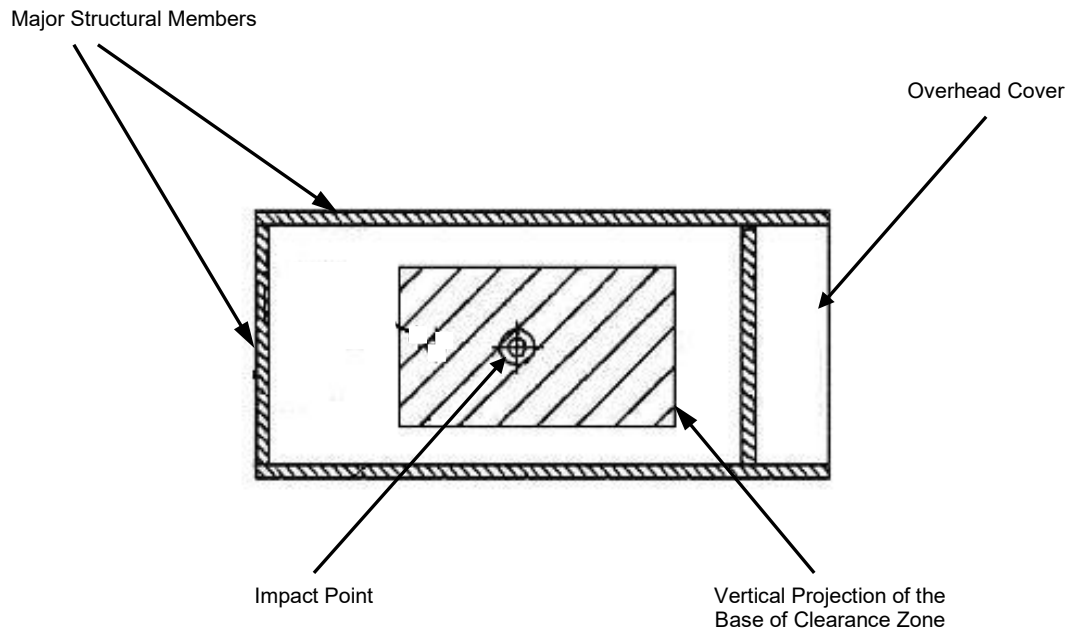
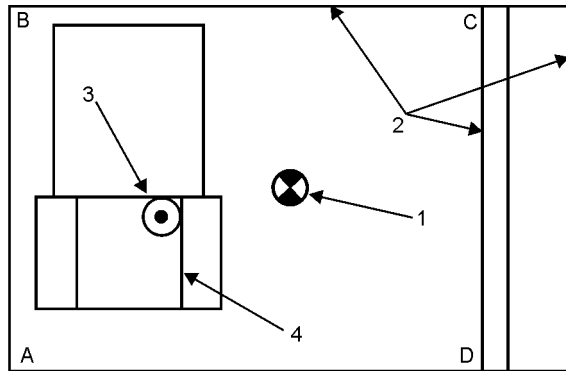

Figure 10.1

Impact point referred to the clearance zone



Case 1

Key

1. Centroid of A-B-C-D
2. Major members
3. Drop object
4. DLV top plane

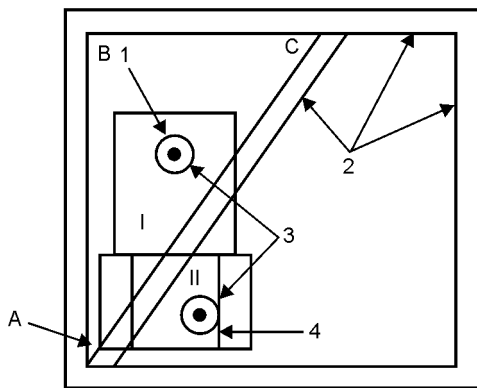

Case 2

Key

1. Centroid of A-B-C
2. Major members
3. Drop object
4. DLV top plane

Note: I has a greater area than II

Figure 10.2

Drop test impact points referred to the DLV

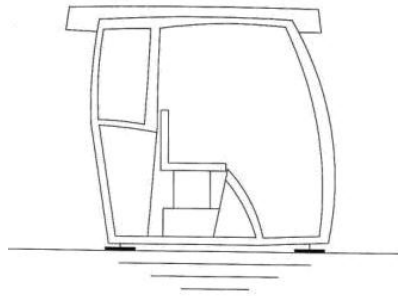

Figure 10.3
Minimum FOPS test configuration
Protective structure rigidly attached to the test bench at its normal mounting location

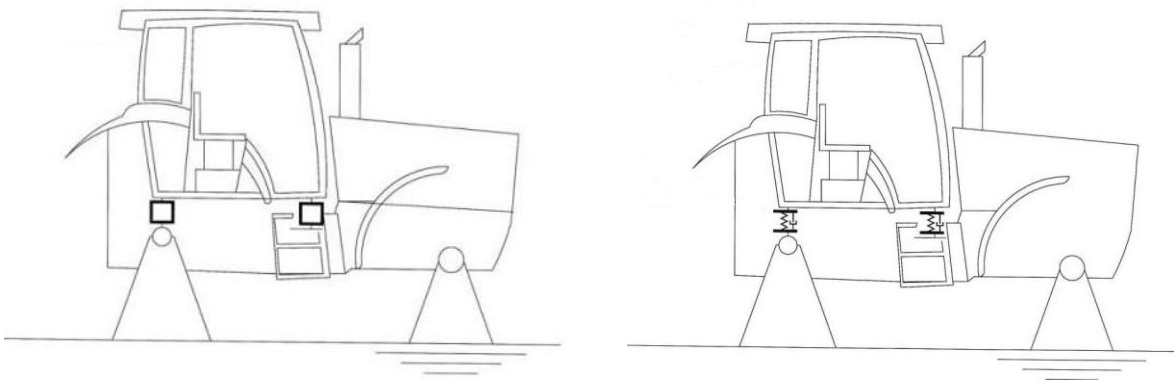

Figure 10.4:- FOPS test configurations when attached to the vehicle chassis
Figure 10.4a (left) by mountings / attachments and Figure 10.4b (right) by suspension components

SPECIMEN TEST REPORT

Note: Units shown below, which appear in ISO 80000-1:2009/Cor.1:2011, shall be stated and followed by national units in parentheses, if necessary.

- Protective structure manufacturer's name and address:
- Submitted for test by:

- Make of the protective structure:
- Model of the protective structure:
- Type of the protective structure: *Cab, Frame, Rear rollbar, Cab with integrated frame, etc.*

- Date, location of test and Code version:

1. SPECIFICATION OF TEST TRACTOR

1.1 Identification of tractor to which the protective structure is fitted for the test

1.1.1 Make of the tractor: (*)

- Model (trade name):
 - Type: 2 WD or 4 WD; rubber or steel tracks (if applicable); articulated 4 WD or articulated 4 WD with twin (dual) wheels (if applicable)
- (*) it may differ from the tractor manufacturer's name

1.1.2 Numbers

- 1st Serial No. or prototype:
- Serial No.:

1.2 Tractor seat

- Tractor with a reversible driver's position (reversible seat and steering wheel): Yes / No
- Make / type / model of seat:
- Make / type / model of optional seat(s) and position(s) of the seat reference point (SRP) or seat index point (SIP):

(description of seat 1 and SRP or SIP position)

(description of seat 2 and SRP or SIP position)

(description of seat _ and SRP or SIP position)

2. SPECIFICATION OF PROTECTIVE STRUCTURE

2.1 **Photographs showing mounting details.** Photographs showing sides, front and rear of the protective structure and mounting details (including mudguards if pertinent).

2.2 **General arrangement drawing** of the structure including position of the seat reference points (SRP or SIP) and details of mountings. The main dimensions must figure on the drawings, including external dimensions of tractor with protective structure fitted and main interior dimensions.

2.3 **Brief description** of the protective structure comprising:

2.3.1 type of construction of:

- ROPS: description or reference to the related OECD Approval number;
- FOPS: description of each part and/or layer constituting the overhead protection;

2.3.2 details of mountings of:

- ROPS: description or reference to the related OECD Approval number;
- FOPS: description of overhead protection mountings;

2.4 Dimensions

When the tractor is fitted with different optional seats or has a reversible driver's position (reversible seat and steering wheel), the dimensions in relation to the seat reference points or the seat index points shall be measured in each case (SRP 1, SRP 2, etc. or SIP 1, SIP 2, etc.).

2.4.1 Height of roof members above the seat reference point or seat index point: mm

2.4.2 Height of roof members above the tractor footplate: mm

2.4.3 Overall height of the tractor with the protective structure fitted: mm

2.4.4 Overall width of the protective structure (if mudguards are included, this is to be stated): mm

2.5 **Details and specifications of materials used in the construction of the protective structure** (Steel specifications shall be in accordance with ISO 630-1,2,3,4:2011-2012; the main properties of plastic materials shall be indicated)

2.5.1 Main frame: (parts – material – sizes)
- Is steel rimmed, semi-killed or killed:
- Steel standard and reference:

2.5.2 ROPS Mountings: (parts – material – sizes or reference to a ROPS OECD Approval number)

2.5.3 ROPS Assembly and mounting bolts: (parts – sizes or reference to a ROPS OECD Approval number)

2.5.4 FOPS: (parts – material – sizes)

2.5.5 FOPS Mountings: (parts – material – sizes)

2.5.6 FOPS Assembly and mounting bolts: (parts – sizes)

2.6 Details of tractor manufacturer’s reinforcements on original parts

2.7 OECD ROPS test report approval number according to Code ____

3. TEST RESULTS

3.1 Falling-object test

3.1.1 Test conditions:

e.g.: Test performed with the roof hatch:

- in the closed - locked position

or

- in the open position

or

- removed

3.1.1.1 Falling object used:

3.1.1.1.1 Sphere:

- Diameter:

mm

- Mass:

kg

3.1.1.1.2 Height of drop:

mm

3.1.1.1.3 Number of drops:

3.1.1.1.4 Energy level met in test:

J

3.1.2 Results:

Statement:

The acceptance conditions of the test are fulfilled. The structure is a Falling Object Protective Structure in accordance with the Code.

3.1.3 Documentation of impact location(s) showing the location relative to the safety zone and providing justification for their selection..

3.1.4 Photographs:

One photograph of the test object and test arrangement before application of test. Additional photograph(s) showing the top and bottom of FOPS structure after the test.

3.2 Cold weather performance (resistance to brittle fracture)

Method used to identify resistance to brittle fracture at reduced temperature:

-

-

Steel specifications shall be in conformity with ISO 630-1,2,3,4:2011-2012.

Steel specification: (reference and relevant standard)

3.3 Tractor(s) to which the protective structure is fitted

OECD Approval Number:										
Make	Model	Type	Other specifications	Mass			Tiltable	Wheel-Base	Minimum track	
		<i>2/4 WD, etc</i>		<i>where applicable</i>	Front	Rear			Total	Front
							<i>Yes/No</i>	mm	mm	

SPECIMEN TECHNICAL EXTENSION REPORT

Note: Units shown below, which appear in ISO 80000-1:2009/Cor.1:2011, shall be stated and followed by national units in parentheses, if necessary.

- Protective structure manufacturer's name and address:
- Submission for extension by:

- Make of the protective structure:
- Model of the protective structure:
- Type of the protective structure: *Cab, Frame, Rear rollbar, Cab with integrated frame, etc.*

- Date, location of extension and Code version:

- Reference of the original test:
- Approval number and date of the original test report:

- Statement giving the reasons of the extension and explaining the procedure chosen (e.g. extension with validation test):

Depending on the case some of the following paragraphs may be omitted if their content is identical to the one of the original test report. It is only necessary to highlight the differences between the tractor and protective structure described in the original test report and the one for which the extension has been required.

1. SPECIFICATION OF TEST TRACTOR

1.1 Identification of tractor to which the protective structure is fitted for the test

- 1.1.1 - Make of the tractor: (*)
- Model (trade name):
- Type: *2 WD or 4 WD; rubber or steel tracks (if applicable); articulated 4 WD or articulated 4 WD with twin (dual) wheels (if applicable)*

(*) possibly different from tractor manufacturer's name

1.1.2 Numbers

- 1st Serial No. or prototype:
- Serial No.:

1.2 Tractor seat

- Tractor with a reversible driver's position (reversible seat and steering wheel): Yes / No
- Make/ type/ model of seat:
- Make/ type/ model of optional seat(s)
- and position(s) of the seat reference point or seat index point (SRP or SIP) :
(description of seat 1 and SRP or SIP position)

(description of seat 2 and SRP or SIP position)

(description of seat ___ and SRP or SIP position)

2. SPECIFICATION OF PROTECTIVE STRUCTURE

2.1 Photographs showing sides, front and rear of the protective structure and mounting details (including mudguards if pertinent).

2.2 General arrangement drawing of the side and the rear of the structure including position of the seat reference (or index) points (SRP or SIP) and details of mountings. The main dimensions must figure on the drawings, including external dimensions of tractor with protective structure fitted and main interior dimensions.

2.3 Brief description of the protective structure comprising:

-- type of construction of:

- ROPS: description or reference to the related OECD Approval number;
- FOPS: description of each part and/or layer constituting the overhead protection;

-- details of mountings of:

- ROPS: description or reference to the related OECD Approval number;
- FOPS: description of overhead protection mountings;

2.4 Dimensions

When the tractor is fitted with different optional seats or has a reversible driver's position (reversible seat and steering wheel), the dimensions in relation to the seat reference points (or seat index points) shall be measured in each case (SRP 1, SRP 2, or SIP 1, SIP 2, etc.).

2.4.1 Height of roof members above the seat reference (or index) point: mm

2.4.2 Height of roof members above the tractor footplate: mm

2.4.3 Overall height of the tractor with the protective structure fitted: mm

2.4.4 Overall width of the protective structure (if mudguards are included, this is to be stated): mm

2.5 Details and specifications of materials used in the construction of the protective structure (Steel specifications shall be in accordance with ISO 630-1,2,3,4:2011-2012; the main properties of plastic materials shall be indicated).

2.5.1 Main frame: (parts – material – sizes)

- Is steel rimmed, semi-killed, killed?:
- Steel standard and reference:

2.5.2 ROPS Mountings: (parts – material – sizes or reference to a ROPS OECD Approval number)

2.5.3 ROPS Assembly and mounting bolts:(parts –sizes or reference to a ROPS OECD Approval number)

2.5.4 FOPS: (parts – material – sizes)

2.5.5 FOPS Mountings: (parts – material – sizes)

2.5.6 FOPS Assembly and mounting bolts: (parts – sizes)

2.6 Details of tractor manufacturer's reinforcements on original parts

2.7 OECD ROPS approval number according to Code XX

3. CONCLUSION

3.1 The difference between the original tested models and the models for which the extension has been required are:

- ...
-

The test station has checked the modifications and certifies that the effect of these modifications do not to affect the results on the strength of the protective structure.

The structure is a falling object protective structure in accordance with the Code.

3.2 Tractor(s) to which the protective structure is fitted

OECD Approval Number:										
Make	Model	Type	Other specifications	Mass			Tiltable	Wheel-Base	Minimum track	
				Front	Rear	Total			Front	Rear
		<i>2/4 WD, etc</i>	<i>where applicable</i>	kg	kg	kg	<i>Yes/No</i>	mm	mm	

SPECIMEN ADMINISTRATIVE EXTENSION REPORT

Note: Units shown below, which appear in ISO 80000-1:2009/Cor.1:2011, shall be stated and followed by national units in parentheses, if necessary.

- Submitted for extension by:
- Date, location of extension and Code version:

- Reference of the original test:
- Approval number and date of the original test:

- Statement giving the reasons of the extension and explaining the procedure chosen.

1. Specification of the protective structure

- Frame or Cab:
- Manufacturer:
- Make:
- Model:
- Type:
- Serial Number from which modification applies:

2. Denomination of tractor(s) to which the protective structure is fitted

OECD Approval Number:										
Make	Model	Type	Other specifications <i>where applicable</i>	Mass			Tiltable <i>Yes/No</i>	Wheel-Base mm	Minimum track	
		<i>2/4 WD, etc</i>		Front	Rear	Total			Front	Rear
				kg	kg	kg			mm	

3. Details of modifications

Since the original test report the following modifications have been made:

4. Statement

The modifications do not to affect the results of the original test.

The original test report therefore applies.

ANNEX I

**CLEARANCE ZONE REFERRED TO
THE SEAT REFERENCE POINT**

INTRODUCTION

The paragraphs considered in the Annex refer to the definitions of the seat reference point (SRP) and the clearance zone of ROPS based on the SRP as the reference point.

In the case of extension reports to test reports that originally used SRP, required measurements shall be made with reference to SRP instead of SIP. Moreover, the use of SRP shall be clearly indicated. For drafting such extension reports, the paragraphs detailed in the Annex should be followed. For the paragraphs non-reported in the Annex, previous versions of Code 3, Code 4, Code 6 or Code 7 should be considered.

1. DEFINITIONS

1.2 Determination of Seat Reference Point; Seat location and adjustment for test

For tractors equipped with ROPS tested in accordance with Code 3 please refer to Section 1.5 in Annex 1 of Code 3.

For tractors equipped with ROPS tested in accordance with Code 4 please refer to Section 1.5 in Annex 1 of Code 4.

For tractors equipped with ROPS tested in accordance with Code 6 please refer to Section 1.5 in Annex 1 of Code 6

For tractors equipped with ROPS tested in accordance with Code 7 please refer to Section 1.5 in Annex 1 of Code 7.

1.3 Safety zone

For tractors equipped with ROPS tested in accordance with Code 3 please refer to Section 1.6 in Annex 1 of Code 3.

For tractors equipped with ROPS tested in accordance with Code 4 please refer to Section 1.6 in Annex 1 of Code 4.

For tractors equipped with ROPS tested in accordance with Code 6 please refer to Section 1.6 in Annex 1 of Code 6.

For tractors equipped with ROPS tested in accordance with Code 7 please refer to Section 1.6 in Annex 1 of Code 7.

NEW AMENDMENTS IN THE 2024 EDITION OF THE OECD TRACTOR CODES

Background

The 2024 edition of the Tractor Codes, released on 1 February 2024, incorporates several amendments as approved by the 2023 Annual Meeting.

Amendments:

General texts

Increase of the Basic fee to 4,000 EUR

Code 2

No change

Code 3

No change

Code 4

No change

Code 5

No change

Code 6

No change

Code 7

No change

Code 8

No Change

Code 9

No change

Code 10

No change