

**CODE 7**

**OECD STANDARD CODE FOR THE OFFICIAL TESTING  
OF REAR MOUNTED ROLL-OVER PROTECTIVE STRUCTURE  
ON NARROW-TRACK AGRICULTURAL  
AND FORESTRY TRACTORS**

Table of contents

1. DEFINITIONS .....	3
1.1 Agricultural and forestry tractors .....	3
1.2 Rolling Over Protective Structure (ROPS).....	3
1.3 Track.....	3
1.4 Wheelbase.....	4
1.5 Determination of seat index point; Seat location and adjustment for test .....	4
1.6 Clearance zone.....	4
1.7 Mass.....	6
1.8 Permissible measurement tolerances .....	7
1.9 Symbols .....	7
2. FIELD OF APPLICATION.....	8
3. RULES AND DIRECTIONS .....	8
3.1 Conditions for testing the strength of protective structures and of their attachment to tractors ..	8
3.2 Static test procedure.....	12
3.3 Extension to other tractor models.....	16
3.4 Labelling.....	18
3.5 Cold weather performance of protective structures.....	18
3.6 Seatbelt anchorage performance.....	20
3.7 Foldable ROPS performance (optional) .....	22
SPECIMEN TEST REPORT .....	43
1. SPECIFICATIONS OF TEST TRACTOR .....	43
2. SPECIFICATIONS OF PROTECTIVE STRUCTURE.....	44
3. TEST RESULTS .....	47
SPECIMEN TECHNICAL EXTENSION REPORT .....	50
1. SPECIFICATION OF TEST TRACTOR.....	50
2. SPECIFICATION OF PROTECTIVE STRUCTURE .....	52
3. TEST RESULTS (in case of a validation test) .....	53
SPECIMEN ADMINISTRATIVE EXTENSION REPORT.....	58
ANNEX I CLEARANCE ZONE REFERRED TO THE SEAT REFERENCE POINT .....	59
INTRODUCTION .....	60
1. DEFINITIONS .....	60
1.5 Determination of seat reference point; seat location and adjustment for test.....	60
1.6 Clearance zone.....	61
ANNEX II DYNAMIC TEST METHOD.....	67
INTRODUCTION .....	68
3.1 Conditions for testing the strength of protective structures and of their attachment to tractors	68
3.2 Dynamic test procedure.....	71
3.3 Extension to other tractor models.....	76
3.4 Labelling.....	76
3.5 Cold weather performance of protective structures.....	76
3.6 Seatbelt anchorage performance.....	76

CODE 7

**OECD STANDARD CODE FOR THE OFFICIAL TESTING  
OF REAR-MOUNTED ROLL-OVER PROTECTIVE STRUCTURES  
ON NARROW-TRACK AGRICULTURAL AND FORESTRY TRACTORS**

**1. DEFINITIONS**

**1.1 *Agricultural and forestry tractors***

Self-propelled wheeled vehicles, having at least two axles, or with tracks, designed to carry out the following operations, primarily for agricultural and forestry purposes:

to pull trailers;

to carry, pull or propel agricultural and forestry tools or machinery and, where necessary, supply power to operate them with the tractor in motion or stationary.

**1.2 *Rolling Over Protective Structure (ROPS)***

Roll-over protective structure (safety cab or frame), hereinafter called “protective structure”, means the structure on a tractor the essential purpose of which is to avoid or limit risks to the driver resulting from roll-over of the tractor during normal use.

The roll-over protective structure is characterized by the provision of space for a clearance zone large enough to protect the driver when seated either inside the envelope of the structure or within a space bounded by a series of straight lines from the outer edges of the structure to any part of the tractor that might come into contact with flat ground and that is capable of supporting the tractor in that position if the tractor overturns.

**1.3 *Track***

**1.3.1 Preliminary definition: median plane of the wheel or track**

The median plane of the wheel is equidistant from the two planes containing the periphery of the rims or tracks at their outer edges.

**1.3.2 Definition of track**

The vertical plane through the wheel axis intersects its median plane along a straight line which meets the supporting surface at one point. If **A** and **B** are the two points thus defined for the wheels on the same axle of the tractor, then the track width is the distance between points **A** and **B**. The track may be thus defined for both front and rear wheels. Where there are twin wheels, the track is the distance between two planes each being the median plane of the pairs of wheels. For tracklaying tractors, the track is the distance between the median planes of the tracks.

### 1.3.3 Additional definition: median plane of the tractor

Take the extreme positions of points **A** and **B** for the tractor rear axle, which gives the maximum possible value for the track. The vertical plane at right angles to the line **AB** at its centre point is the median plane of the tractor.

## 1.4 *Wheelbase*

The distance between the vertical planes passing through the two lines **AB** as defined above, one for the front wheels and one for the rear-wheels.

## 1.5 *Determination of seat index point; Seat location and adjustment for test*

### 1.5.1 Seat index point (SIP)<sup>1</sup>

The seat index point shall be determined in accordance with ISO 5353:1995

### 1.5.2 Seat location and adjustment for test

1.5.2.1 where the seat position is adjustable, the seat must be adjusted to its rear uppermost position;

1.5.2.2 where the inclination of the backrest is adjustable, it must be adjusted to the mid position;

1.5.2.3 where the seat is equipped with suspension, the latter must be blocked at mid-travel, unless this is contrary to the instructions clearly laid down by the seat manufacturer;

1.5.2.4 where the position of the seat is adjustable only lengthwise and vertically, the longitudinal axis passing through the seat index point shall be parallel with the vertical longitudinal plane of the tractor passing through the centre of the steering wheel and not more than 100 mm from that plane.

## 1.6 *Clearance zone*

### 1.6.1 Reference plane

The clearance zone is illustrated in Figures 7.1 and 7.2. The zone is defined in relation to the reference plane and the seat index point (SIP). The reference plane is a vertical plane, generally longitudinal to the tractor and passing through the seat index point and the centre of the steering wheel. Normally the reference plane coincides with the longitudinal median plane of the tractor. This reference plane shall be assumed to move horizontally with the seat and steering wheel during loading but to remain perpendicular to the tractor or the floor of the roll-over protective structure. The clearance zone shall be defined on the basis of Sections 1.6.2 and 1.6.3.

### 1.6.2 Determination of the clearance zone for tractors with a non-reversible seat

The clearance zone for tractors with a non-reversible seat is defined in 1.6.2.1 to 1.6.2.13 below and is bounded by the following planes, the tractor being on a horizontal surface, the seat adjusted and located as

---

<sup>1</sup> For extension tests to test reports that originally used seat reference point (SRP), the required measurements shall be made with reference to SRP instead of SIP and the use of SRP shall be clearly indicated (see Annex I).

specified in Sections 1.5.2.1 to 1.5.2.4<sup>2</sup>, and the steering wheel, where adjustable, adjusted to the mid position for seated driving:

1.6.2.1 a horizontal plane **A<sub>1</sub> B<sub>1</sub> B<sub>2</sub> A<sub>2</sub>**,  $(810 + a_v)$  mm above the seat index point (SIP) with line **B<sub>1</sub>B<sub>2</sub>** located  $(a_h-10)$  mm behind the SIP;

1.6.2.2 an inclined plane **H<sub>1</sub> H<sub>2</sub> G<sub>2</sub> G<sub>1</sub>**, perpendicular to the reference plane, including both a point 150 mm behind line **B<sub>1</sub>B<sub>2</sub>** and the rearmost point of the seat backrest;

1.6.2.3 a cylindrical surface **A<sub>1</sub> A<sub>2</sub> H<sub>2</sub> H<sub>1</sub>** perpendicular to the reference plane, having a radius of 120 mm, tangential to the planes defined in 1.6.2.1 and 1.6.2.2 above;

1.6.2.4 a cylindrical surface **B<sub>1</sub> C<sub>1</sub> C<sub>2</sub> B<sub>2</sub>**, perpendicular to the reference plane, having a radius of 900 mm extending forward for 400 mm and tangential to the plane defined in 1.6.2.1 above along line **B<sub>1</sub>B<sub>2</sub>**;

1.6.2.5 an inclined plane **C<sub>1</sub> D<sub>1</sub> D<sub>2</sub> C<sub>2</sub>**, perpendicular to the reference plane, joining the surface defined in 1.6.2.4 above and passing 40 mm from the forward external edge of the steering wheel. In the case of a high steering wheel position, this plane extends forward from line **B<sub>1</sub>B<sub>2</sub>** tangentially to the surface defined in 1.6.2.4 above;

1.6.2.6 a vertical plane **D<sub>1</sub> K<sub>1</sub> E<sub>1</sub> E<sub>2</sub> K<sub>2</sub> D<sub>2</sub>** perpendicular to the reference plane 40 mm forward of the external edge of the steering wheel;

1.6.2.7 a horizontal plane **E<sub>1</sub> F<sub>1</sub> P<sub>1</sub> N<sub>1</sub> N<sub>2</sub> P<sub>2</sub> F<sub>2</sub> E<sub>2</sub>** passing through a point  $(90-a_v)$  mm below the seat index point (SIP);

1.6.2.8 a surface **G<sub>1</sub> L<sub>1</sub> M<sub>1</sub> N<sub>1</sub> N<sub>2</sub> M<sub>2</sub> L<sub>2</sub> G<sub>2</sub>**, if necessary curved from the bottom limit of the plane defined in 1.6.2.2 above to the horizontal plane defined in 1.6.2.7 above, perpendicular to the reference plane, and in contact with the seat backrest throughout its length;

1.6.2.9 two vertical planes **K<sub>1</sub> I<sub>1</sub> F<sub>1</sub> E<sub>1</sub>** and **K<sub>2</sub> I<sub>2</sub> F<sub>2</sub> E<sub>2</sub>** parallel to the reference plane, 250 mm either side of the reference plane, and bounded at the top 300 mm above the plane defined in 1.6.2.7 above;

1.6.2.10 two inclined and parallel planes **A<sub>1</sub> B<sub>1</sub> C<sub>1</sub> D<sub>1</sub> K<sub>1</sub> I<sub>1</sub> L<sub>1</sub> G<sub>1</sub> H<sub>1</sub>** and **A<sub>2</sub> B<sub>2</sub> C<sub>2</sub> D<sub>2</sub> K<sub>2</sub> I<sub>2</sub> L<sub>2</sub> G<sub>2</sub> H<sub>2</sub>** starting from the upper edge of the planes defined in 1.6.2.9 above and joining the horizontal plane defined in 1.6.2.1 above at least 100 mm from the reference plane on the side where the loading is applied;

1.6.2.11 two portions of vertical planes **Q<sub>1</sub> P<sub>1</sub> N<sub>1</sub> M<sub>1</sub>** and **Q<sub>2</sub> P<sub>2</sub> N<sub>2</sub> M<sub>2</sub>** parallel to the reference plane, 200 mm either side of the reference plane, and bounded towards the top 300 mm above the horizontal plane defined in 1.6.2.7 above;

1.6.2.12 two portions of **I<sub>1</sub> Q<sub>1</sub> P<sub>1</sub> F<sub>1</sub>** and **I<sub>2</sub> Q<sub>2</sub> P<sub>2</sub> F<sub>2</sub>** of a vertical plane, perpendicular to the reference plane and passing  $(210-a_h)$  mm in front of the SIP;

---

<sup>2</sup> Users are reminded that the seat index point is determined according to ISO 5353 and is a fixed point with respect to the tractor that does not move as the seat is adjusted away from the mid position.

1.6.2.13 two portions  $I_1 Q_1 M_1 L_1$  and  $I_2 Q_2 M_2 L_2$  of the horizontal plane passing 300 mm above the plane defined in 1.6.2.7 above.

### 1.6.3 Determination of the clearance zone for tractors with a reversible driver's position

For tractors with a reversible driver's position (reversible seat and steering wheel), the clearance zone is the envelope of the two clearance zones defined by the two different positions of the steering wheel and the seat.

**1.6.3.1** If the protective structure is a of a rear two-post type, for each position of the steering wheel and of the seat, the clearance zone shall respectively be defined on the basis of above sections 1.6.1 and 1.6.2 of present Code for driver's position in normal position, and on the basis of sections 1.6.1 and 1.6.2 of Code 6 for driver's position in reverse position (see Figure 7.2.a).

**1.6.3.2** If the protective structure is of another type, for each position of the steering wheel and of the seat, the clearance zone shall be defined on the basis of sections 1.6.1 and 1.6.2 of the present Code (see Figure 7.2.b).

### 1.6.4 Optional seats

1.6.4.1 In case of tractors that could be fitted with optional seats, the envelope comprising the seat index points of all options offered shall be used during the tests. The protective structure shall not enter the larger clearance zone which takes account of these different seat index points.

1.6.4.2 In the case where a new seat option is offered after the test has been performed, a determination shall be made to see whether the clearance zone around the new SIP falls within the envelope previously established. If it does not, a new test must be performed.

1.6.4.3 Optional seat does not include a seat for a person in addition to the driver and from where the tractor cannot be controlled. The SIP shall not be determined because the definition of the clearance zone is in relation to the driver seat.

## 1.7 Mass

### 1.7.1 Unballasted / Unladen Mass

The mass of the tractor excluding optional accessories but including coolant, oils, fuel, tools plus the protective structure. Not included are optional front or rear weights, tyre ballast, mounted implements, mounted equipment or any specialised components;

### 1.7.2 Maximum Permissible Mass

The maximum mass of the tractor stated by the manufacturer to be technically permissible and declared on the vehicle's identification plate and/or in the Operator's Handbook;

### 1.7.3 Reference Mass

The mass, selected by the manufacturer, used in formulae to calculate the height of fall of the pendulum block, the energy inputs and crushing forces to be used in the tests. Must not be less than the unballasted mass and must be sufficient to ensure the Mass Ratio does not exceed 1.75 (see sections 1.7.4 and 2.1.3);

### 1.7.4 Mass Ratio

The ratio of  $\left( \frac{\text{Max. Permissible Mass}}{\text{Reference Mass}} \right)$  ..... This must not be greater than 1.75

**1.8 Permissible measurement tolerances**

Linear dimension:	± 3 mm
except for: -- tyre deflection :	± 1 mm
-- structure deflection during horizontal loadings:	± 1 mm
-- height of fall of the pendulum block:	± 1 mm
Masses:	± 1 %
Forces: ± 2 %	
Angles:	± 2 °

**1.9 Symbols**

<b><math>a_h</math></b>	(mm)	Horizontal distance between the seat adjusted according to the point 1.5.1 and the seat adjusted according to the point 1.5.2
<b><math>a_v</math></b>	(mm)	Vertical distance between the seat adjusted according to the point 1.5.1 and the seat adjusted according to the point 1.5.2
<b>B</b>	(mm)	Minimum overall width of the tractor;
<b><math>B_6</math></b>	(mm)	Maximum outer width of the protective structure;
<b>D</b>	(mm)	Deflection of the structure at the point of impact (dynamic tests) or at the point of, and in line with, the load application (static tests);
<b>D'</b>	(mm)	Deflection of the structure for the calculated energy required;
<b><math>E_a</math></b>	(J)	Strain energy absorbed at point when load is removed. Area contained within <b>F-D</b> curve;
<b><math>E_i</math></b>	(J)	Strain energy absorbed. Area under <b>F-D</b> curve;
<b><math>E'_i</math></b>	(J)	Strain energy absorbed after additional loading following a crack or tear;
<b><math>E''_i</math></b>	(J)	Strain energy absorbed in overload test in the event of the load having been removed before starting this overload test. Area under <b>F-D</b> curve;
<b><math>E_{il}</math></b>	(J)	Energy input to be absorbed during longitudinal loading;
<b><math>E_{is}</math></b>	(J)	Energy input to be absorbed during side loading;
<b>F</b>	(N)	Static load force;
<b>F'</b>	(N)	Loading force for calculated energy required, corresponding to <b><math>E'_i</math></b> ;
<b>F-D</b>		Force/deflection diagram;
<b><math>F_{max}</math></b>	(N)	Maximum static load force occurring during loading, with the exception of the overload;
<b><math>F_v</math></b>	(N)	Vertical crushing force;
<b>H</b>	(mm)	Falling height of the pendulum block (dynamic tests);
<b>H'</b>	(mm)	Falling height of the pendulum block for additional test (dynamic tests);
<b>I</b>	(kgm <sup>2</sup> )	Tractor reference moment of inertia about the centre line of the rear wheels, whatever the mass of these rear wheels may be;
<b>L</b>	(mm)	Tractor reference wheelbase;
<b>M</b>	(kg)	Tractor reference mass during strength tests.

## 2. FIELD OF APPLICATION

2.1 This OECD Standard Code is applicable to tractors having at least two axles for pneumatic tyred wheels or having tracks instead of wheels and shall apply to tractors having the following characteristics:

2.1.1 ground clearance of not more than 600 mm beneath the lowest points of the front and rear axles, allowing for the differential;

2.1.2 fixed or adjustable minimum track width with one of the axles less than 1 150 mm fitted with tyres of a larger size. It is assumed that the axle mounted with the wider tyres is set at a track width of not more than 1 150 mm. It must be possible to set the track width of the other axle in such a way that the outer edges of the narrower tyres do not go beyond the outer edges of the tyres of the other axle. Where the two axles are fitted with rims and tyres of the same size, the fixed or adjustable track width of the two axles must be less than 1 150 mm;

2.1.3 mass greater than 400 kg unladen but including the roll-over protective structure and tyres of the largest size recommended by the manufacturer. For tractors with a reversible driver's position (reversible seat and steering wheel), the unladen mass shall be less than 3 500 kg and the maximum permissible mass shall not exceed 5 250 kg. For all tractors, the Mass Ratio (*Maximum Permissible Mass / Reference Mass*) must not be greater than 1.75.

2.1.4 roll-over protective structure of the rollbar, frame or cab type, mounted partly or entirely behind the Seat Index Point and having a zone of clearance whose upper limit is  $(810 + a_v)$  mm above the seat index point in order to provide a sufficiently large area or unobstructed space for the protection of the driver.

2.2 It is recognised that there may be designs of tractors, for example, special forestry machines, such as forwarders and skidders, for which this Standard Code is not applicable.

## 3. RULES AND DIRECTIONS

### 3.1 *Conditions for testing the strength of protective structures and of their attachment to tractors*

#### 3.1.1 General requirements

##### 3.1.1.1 Test purposes

Tests made using special rigs are intended to simulate such loads as are imposed on a protective structure, when the tractor overturns. These tests enable observations to be made on the strength of the protective structure and any brackets attaching it to the tractor and any parts of the tractor which transmit the test load.

##### 3.1.1.2 Test methods

Tests may be performed in accordance with the static procedure or the dynamic procedure (see Annex II). The two methods are deemed equivalent.

##### 3.1.1.3 General rules governing preparation for tests

3.1.1.3.1 The protective structure must conform to the series production specifications. It shall be attached in accordance with the manufacturer's recommended method to one of the tractors for which it is designed.



**Note:** A complete tractor is not required for the static strength test; however, the protective structure and parts of the tractor to which it is attached represent an operating installation, hereinafter referred to as « the assembly ».

3.1.1.3.2 For both the static test and the dynamic test the tractor as assembled (or the assembly) must be fitted with all series production components which may affect the strength of the protective structure or which may be necessary for the strength test.

Components which may create a hazard in the clearance zone must also be fitted on the tractor (or the assembly) so that they may be examined to see whether the requirements of the Acceptance Conditions in 3.1.3 have been fulfilled. All components of the tractor or the protective structure including weather protective must be supplied or described on drawings.

3.1.1.3.3 For the strength tests, all panels and detachable non-structural components must be removed so that they may not contribute to the strengthening of the protective structure.

3.1.1.3.4 The track width must be adjusted so that the protective structure will, as far as possible, not be supported by the tyres or the tracks during the strength tests. If these tests are conducted in accordance with the static procedure, the wheels or tracks may be removed.

## 3.1.2 Tests

### 3.1.2.1 Sequence of tests according to the Static Procedure

The sequence of tests, without prejudice to the additional tests mentioned in sections 3.2.1.6, and 3.2.1.7 is as follows:

- (1) **loading at the rear of the structure**  
(see 3.2.1.1);
- (2) **crushing at the rear of the structure**  
(see 3.2.1.4);
- (3) **loading at the front of the structure**  
(see 3.2.1.2);
- (4) **loading at the side of the structure**  
(see 3.2.1.3);
- (5) **crushing at the front of the structure**  
(see 3.2.1.5).

### 3.1.2.2 General requirements

3.1.2.2.1 If, during the test, any part of the tractor restraining equipment breaks or moves, the test shall be restarted.

3.1.2.2.2 No repairs or adjustments of the tractor or protective structure may be carried out during the tests.

3.1.2.2.3 The tractor gear box shall be in neutral and the brakes off during the tests.

3.1.2.2.4 If the tractor is fitted with a suspension system between the tractor body and the wheels, it shall be blocked during the tests.

3.1.2.2.5 The side chosen for application of the first load on the rear of the structure shall be that which, in the opinion of the testing authorities, will result in the application of the series of loads under the most unfavourable conditions for the structure. The lateral load shall be applied to the opposite side of the median plane of the tractor than the longitudinal load. The front load shall be applied on the same side of the longitudinal median plane of the protective structure as the lateral load.

### 3.1.3 Acceptance conditions

3.1.3.1 A protective structure is regarded as having satisfied the strength requirements if it fulfils the following conditions:

3.1.3.1.1 during static testing, at the point when the energy required is attained in each horizontal load test prescribed or in the overload test the force must be greater than 0.8 F;

3.1.3.1.2 if during the test, cracks or tears appear as a result of the application of the crushing force, an additional crushing test as defined in 3.2.1.7 must be performed immediately after the crushing test which caused these cracks or tears to appear;

3.1.3.1.3 during the tests other than the overload test, no part of the protective structure must enter the clearance zone as defined in 1.6;

3.1.3.1.4 during the tests other than the overload test, all parts of the clearance zone shall be secured by the structure, in accordance with 3.2.2.2;

3.1.3.1.5 during the tests the protective structure must not impose any constraints on the seat structure;

3.1.3.1.6 the elastic deflection, measured in accordance with 3.2.2.3 shall be less than 250 mm.

3.1.3.2 There shall be no accessories presenting a hazard for the driver. There shall be no projecting part or accessory which is liable to injure the driver should the tractor overturn, or any accessory or part which is liable to trap him – for example by the leg or the foot – as a result of the deflections of the structure.

### 3.1.4 Test report

3.1.4.1 The report shall include:

3.1.4.1.1 a general description of the protective structure's shape and construction (normally at least a scale of 1/20 for the general drawings and 1/2.5 for drawing of the attachments).

The main dimensions must figure on the drawings, including external dimensions of tractor with protective structure fitted and main interior dimensions;

3.1.4.1.2 a general description of materials and fastening;

3.1.4.1.3 details of provisions for normal entry and exit and for escape where appropriate;

3.1.4.1.4 details of heating and ventilation system, where appropriate;

3.1.4.1.5 a brief description of any interior padding, where appropriate.

3.1.4.2 The test report must clearly identify the tractor (make, type, model, trade name, etc.) used for testing and the other tractors for which the protective structure is intended.

### 3.1.5 Test apparatus and equipment

#### 3.1.5.1 Static testing rig

3.1.5.1.1 The static testing rig must be designed in such a way as to permit thrusts or loads to be applied to the protective structure.

3.1.5.1.2 Provision must be made so that the load can be uniformly distributed normal to the direction of loading and along a flange having a length of one of the exact multiples of 50 between 250 and 700 mm. The stiff beam shall have a vertical face dimension of 150 mm. The edges of the beam in contact with the protective structure shall be curved with a maximum radius of 50 mm.

3.1.5.1.3 The pad shall be capable of being adjusted to any angle in relation to the load direction, in order to be able to follow the angular variations of the structure's load-bearing surface as the structure deflects.

3.1.5.1.4 Direction of the force (deviation from horizontal and vertical):

- at start of test, under zero load:  $\pm 2^\circ$ ;
- during test, under load:  $10^\circ$  above and  $20^\circ$  below the horizontal. These variations must be kept to a minimum.

3.1.5.1.5 The deflection rate shall be sufficiently slow, less than 5 mm/s so that the load may at all moments be considered as static.

#### 3.1.5.2 Apparatus for measuring the energy absorbed by the structure

3.1.5.2.1 The force versus deflection curve shall be plotted in order to determine the energy absorbed by the structure. There is no need to measure the force and deflection at the point where the load is applied to the structure; however, force and deflection shall be measured simultaneously and co-linearly.

3.1.5.2.2 The point of origin of deflection measurements shall be selected so as to take account only of the energy absorbed by the structure and/or by the deflection of certain parts of the tractor. The energy absorbed by the deflection and/or the slipping of the anchoring must be ignored.

#### 3.1.5.3 Means of anchoring the tractor to the ground

3.1.5.3.1 Anchoring rails with the requisite track width and covering the necessary area for anchoring the tractor in all the cases illustrated must be rigidly attached to a non-yielding base near the testing rig.

3.1.5.3.2 The tractor must be anchored to the rails by any suitable means (plates, wedges, wire ropes, jacks, etc.) so that it cannot move during the tests. This requirement shall be checked during the test, by means of the usual devices for measuring length.

If the tractor moves, the entire test shall be repeated, unless the system for measuring the deflections taken into account for plotting the force versus deflection curve is connected to the tractor.

#### 3.1.5.4 Crushing rig

A rig as shown in Figure 7.3 shall be capable of exerting a downward force on a protective structure through a rigid beam approximately 250 mm wide, connected to the load-applying mechanism by means of universal joints. Suitable axle stands must be provided so that the tractor tyres do not bear the crushing force.

#### 3.1.5.5 Other measuring apparatus

The following measuring devices are also needed:

3.1.5.5.1 device for measuring the elastic deflection (the difference between the maximum momentary deflection and the permanent deflection, see Figure 7.4).

3.1.5.5.2 device for checking that the protective structure has not entered the clearance zone and that the latter has remained within the structure's protective during the test (section 3.2.2.2).

### 3.2 *Static test procedure*

#### 3.2.1 Loading and crushing tests

##### 3.2.1.1 Loading at the rear

3.2.1.1.1 The load shall be applied horizontally and parallel to the median plane of the tractor.

The load shall be applied to the uppermost transverse structural member of the protective structure (i.e. that part which would be likely to strike the ground first in an overturn).

The point of application of the load shall be located at one sixth of the width of the top of the protective structure inwards from the outside corner. The width of the protective structure shall be taken as the distance between two lines parallel to the median plane of the tractor touching the outside extremities of the protective structure in the horizontal plane touching the top of the uppermost transverse structural members.

In the event that the ROPS is formed of curved members and no appropriate corners exist, the following general procedure shall apply for determining W. The test engineer shall identify the curved member most likely to first strike ground in the event of an asymmetrical overturn (e.g. an overturn where one side of the ROPS is likely to bear the initial loading). The endpoints of W shall be the mid-points of the external radii created between other straight or curved members which form the uppermost ROPS structure. In the event that multiple curved members could be selected, the test engineer shall establish ground lines for each possible member to determine which surface is most likely to strike ground first. See Figure 7.3 b) and c) for examples.

NOTE In the event of curved members, only the width at the end of the structure to which the longitudinal load is to be applied need be considered

The length of the load distribution device (see 3.1.5.1.2) shall be not less than one third of the width of the protective structure and not more than 49 mm greater than this minimum.

3.2.1.1.2 The energy absorbed by the protective structure during the test shall be at least:

$$E_{it} = 2.165 \times 10^{-7} M L^2$$

or

$$E_{it} = 0.574 \times I$$

3.2.1.1.3 For tractors with a reversible driver's position (reversible seat and steering wheel), the energy shall be whichever is the higher of the formula selected above or the following:

$$E_{it} = 500 + 0.5 M$$

3.2.1.2 Loading at the front

3.2.1.2.1 The load shall be applied horizontally and parallel to the median plane of the tractor.

The load shall be applied to the uppermost transverse structural member of the protective structure (i.e. that part which would be likely to strike the ground first in an overturn).

The point of application of the load shall be located at one sixth of the width of the top of the protective structure inwards from the outside corner. The width of the protective structure shall be taken as the distance between two lines parallel to the median plane of the tractor touching the outside extremities of the protective structure in the horizontal plane touching the top of the uppermost transverse structural members.

In the event that the ROPS is formed of curved members and no appropriate corners exist, the following general procedure shall apply for determining W. The test engineer shall identify the curved member most likely to first strike ground in the event of an asymmetrical overturn (e.g. an overturn where one side of the ROPS is likely to bear the initial loading). The endpoints of W shall be the mid-points of the external radii created between other straight or curved members, which form the uppermost ROPS structure. In the event that multiple curved members could be selected, the test engineer shall establish ground lines for each possible member to determine which surface is most likely to strike ground first. See Figure 7.3 b) and c) for examples.

3.2.1.2.2 The energy absorbed by the protective structure during the test shall be at least:

$$E_{it} = 500 + 0.5 M$$

3.2.1.2.3 In case of tractors with a reversible driver's position (reversible seat and steering wheel):

- if the protective structure is a rear two-post rollbar the preceding formula shall also apply;
- for other types of protective structures, the energy shall be whichever is the higher of the above or either of the following as selected:

$$E_{il} = 2.165 \times 10^{-7} ML^2$$

or

$$E_{il} = 0.574 I$$

### 3.2.1.3 Loading at the side

3.2.1.3.1 The side loading shall be applied horizontally, in a vertical plane perpendicular to the tractor's median plane passing 60 mm in front of the seat index point, the seat being at the mid position of the longitudinal adjustment. The load application point shall be that part of the roll-over protective structure likely to hit the ground first in a sideways overturning accident, normally the upper edge.

3.2.1.3.2 The assembly shall be lashed to the ground as described in 3.1.5.3.

3.2.1.3.3 The energy absorbed by the protective structure during the test shall be at least:

$$E_{is} = 1.75 M$$

3.2.1.3.4 For tractors with a reversible driver's position (reversible seat and steering wheel), the load application point shall be in the plane at right angles to the median plane and passing at the midpoint of the segment joining the two seat index points defined by joining the two different positions of the seat. For protective structures having a two-post system, the load shall be located on one of the two posts.

3.2.1.3.5 In case of tractors with a reversible driver's position (reversible seat and steering wheel) where the protective structure is a rear two-post rollbar, the energy shall be whichever is higher of the following:

$$E_{is} = 1.75 M$$

or

$$E_{is} = 1.75 M (B_6 + B)/2B$$

### 3.2.1.4 Crushing at the rear

The beam shall be positioned over the rear uppermost structural member(s) and the resultant of crushing forces shall be located in the tractor's median plane. A force  $F_v$  shall be applied where:

$$F_v = 20 M$$

The force  $F_v$  shall be maintained for five seconds after the cessation of any visually detectable movement of the protective structure.

Where the rear part of the protective structure roof will not sustain the full crushing force, the force shall be applied until the roof is deflected to coincide with the plane joining the upper part of

the protective structure with that part of the rear of the tractor capable of supporting the tractor when overturned.

The force shall then be removed, and the crushing beam repositioned over that part of the protective structure which would support the tractor when completely overturned. The crushing force  $F_v$  shall then be applied again.

#### 3.2.1.5 Crushing at the front

The beam shall be positioned across the front uppermost structural member(s) and the resultant of crushing forces shall be located in the tractor's median plane. A force  $F_v$  shall be applied where:

$$F_v = 20 M$$

The force  $F_v$  shall be maintained for five seconds after the cessation of any visually detectable movement of the protective structure.

Where the front part of the protective structure roof will not sustain the full crushing force, the force shall be applied until the roof is deflected to coincide with the plane joining the upper part of the protective structure with that part of the front of the tractor capable of supporting the tractor when overturned.

The force shall then be removed, and the crushing beam repositioned over that part of the protective structure which would support the tractor when completely overturned. The crushing force  $F_v$  shall then be applied again.

#### 3.2.1.6 Additional overload test (Figures 7.5 to 7.7)

An overload test shall be carried out in all cases where the force decreases by more than 3 per cent during the last 5 per cent of the deflection reached when the energy required is absorbed by the structure (see Figure 7.6).

The overload test involves the gradual increase of the horizontal load by increments of 5 per cent of the initial energy requirement up to a maximum of 20 per cent of energy added (see Figure 7.7).

The overload test is satisfactory if, after each increase by 5, 10, or 15 per cent in the energy required, the force decreases by less than 3 per cent for a 5 per cent increment and remains greater than **0.8  $F_{max}$** .

The overload test is satisfactory if, after the structure has absorbed 20 per cent of the added energy, the force exceeds **0.8  $F_{max}$** .

Additional cracks or tears and/or entry into or lack of protective of the clearance zone due to elastic deflection are permitted during the overload test. However, after the removal of the load, the structure shall not enter the clearance zone, which shall be completely protected.

#### 3.2.1.7 Additional crushing tests

If cracks or tears which cannot be considered as negligible appear during a crushing test, a second, similar crushing, but with a force of **1.2  $F_v$**  shall be applied immediately after the crushing test which caused the cracks or tears to appear.

Additional cracks or tears or entry into or lack of protection of the clearance zone, due to elastic deformation, are permitted during the additional crushing test. After removing the load, however, the protective structure shall not infringe on the clearance zone, which shall be completely protected.

### 3.2.2 Measurements to be made

#### 3.2.2.1 Fractures and cracks

After each test all structural members, joints and attachment systems shall be visually examined for fractures or cracks, any small cracks in unimportant parts being ignored.

#### 3.2.2.2 Entry into the clearance zone

During each test the protective structure shall be examined to see whether any part of it has entered a clearance zone as defined in 1.6 above.

Furthermore, the clearance zone shall not be outside the protection of the protective structure. For this purpose it is considered to be outside the protection of the roll-over protective structure if any part of it would have come in contact with the ground plane if the tractor had overturned in the direction from which the impact came. For this purpose the front and rear tyres and track setting are assumed to be the smallest specified by the manufacturer.

#### 3.2.2.3 Elastic deflection under side loading

The elastic deflection shall be measured  $(810 + a_v)$  mm above the seat index point, in the vertical plane in which the load is applied. For this measurement, any apparatus similar to that illustrated in Figure 7.4 may be used.

#### 3.2.2.4 Permanent deflection

After the final crushing test, the permanent deflection of the protective structure shall be recorded. For this purpose, before the start of the test, the position of the main roll-over protective structure members in relation to the seat index point shall be used.

### 3.3 *Extension to other tractor models*

#### 3.3.1 Administrative extension

If there are changes in the make, denomination or marketing features of the tractor or protective structure tested or listed in the original test report, the testing station that has carried out the original test can issue an “administrative extension report”. This extension report shall contain a reference to the original test report.

#### 3.3.2 Technical extension

When technical modifications occur on the tractor, the protective structure or the method of attachment of the protective structure to the tractor, the testing station that has carried out the original test can issue a “technical extension report” in the following cases:

##### 3.3.2.1 Extension of the structural test results to other models of tractors



Loading and crushing tests need not be carried out on each model of tractor, provided that the protective structure and tractor comply with the conditions referred to hereunder 3.3.2.1.1 to 3.3.2.1.5.

3.3.2.1.1 The structure shall be identical to the one tested;

3.3.2.1.2 The required energy shall not exceed the energy calculated for the original test by more than 5 per cent; the 5 % limit shall also apply to extensions in the case of substituting tracks for wheels on the same tractor.

3.3.2.1.3 The method of attachment and the tractor components to which the attachment is made shall be identical;

3.3.2.1.4 Any components such as mudguards and bonnet that may provide support for the protective structure shall be identical;

3.3.2.1.5 The position and critical dimensions of the seat in the protective structure and the relative position of the protective structure on the tractor shall be such that the clearance zone would have remained within the protection of the deflected structure throughout all tests (this shall be checked by using the same reference of clearance zone as in the original test report, respectively Seat Reference Point [SRP] or Seat Index Point [SIP]).

3.3.2.2 Extension of the structural test results to modified models of the protective structure

This procedure has to be followed when the provisions of paragraph 3.3.2.1 are not fulfilled, it may not be used when the method of attachment of the protective structure to the tractor does not remain of the same principle (e.g. rubber supports replaced by a suspension device):

3.3.2.2.1 Modifications having no impact on the results of the initial test (e.g. weld attachment of the mounting plate of an accessory in a non-critical location on the structure), addition of seats with different SIP location in the protective structure (subject to checking that the new clearance zone(s) remain(s) within the protection of the deflected structure throughout all tests).

3.3.2.2.2 Modifications having a possible impact on the results of the original test without calling into question the acceptability of the protective structure (e.g. modification of a structural component, modification of the method of attachment of the protective structure to the tractor). A validation test can be carried out and the test results will be drafted in the extension report.

The following limits for this type extension are fixed:

3.3.2.2.2.1 no more than 5 extension may be accepted without a validation test;

3.3.2.2.2.2 the results of the validation test will be accepted for extension if all the acceptance conditions of the Code are fulfilled and:

- if the deflection measured after each impact test does not deviate from the deflection measured after each impact test in the original test report by more than  $\pm 7\%$  (in case of a dynamic test);
- if the force measured when the required energy level has been reached in the various horizontal load tests does not deviate from the force measured when the required energy has

been reached in the original test by more than  $\pm 7\%$  and the deflection measured<sup>3</sup> when the required energy level has been reached in the various horizontal load tests does not deviate from the deflection measured when the required energy has been reached in the original test by more than  $\pm 7\%$  (in case of a static test).

3.3.2.2.3 more than one protective structure modifications may be included in a single extension report if they represent different options of the same protective structure, but only one validation test can be accepted in a single extension report. The options not tested shall be described in a specific section of the extension report.

3.3.2.2.3 Increase of the reference mass declared by the manufacturer for a protective structure already tested. If the manufacturer wants to keep the same approval number it is possible to issue an extension report after having carried out a validation test (the limits of  $\pm 7\%$  specified in 3.3.2.2.2 are not applicable in such a case).

### **3.4 Labelling**

3.4.1 OECD labelling is optional. If it is utilised, it shall contain at least the following information:

3.4.1.1 OECD reference;

3.4.1.2 OECD approval number.

3.4.2 The label shall be durable and permanently attached to the protective structure so that it can be easily read and it shall be protected from environmental damage.

### **3.5 Cold weather performance of protective structures**

3.5.1 If the protective structure is claimed to have properties resistant to cold weather embrittlement, the manufacturer shall give details that shall be included in the report.

3.5.2 The following requirements and procedures are intended to provide strength and resistance to brittle fracture at reduced temperatures. It is suggested that the following minimum material requirements shall be met in judging the protective structure's suitability at reduced operating temperatures in those countries requiring this additional operating protection.

3.5.2.1 Bolts and Nuts used to attach the protective structure to the tractor and used to connect structural parts of the protective structure shall exhibit suitable controlled reduced temperature toughness properties.

3.5.2.2 All welding electrodes used in the fabrication of structural members and mounts shall be compatible with the protective structure material as given in 3.5.2.3 below.

3.5.2.3 Steel materials for structural members of the protective structure shall be of controlled toughness material exhibiting minimum Charpy V-Notch impact energy requirements as shown in Table 7.1. Steel grade and quality shall be specified in accordance with ISO 630-1,2,3,4:2011-2012.

---

<sup>3</sup> Permanent + elastic deflection measured at the point when the required energy level is obtained.

Steel with an as-rolled thickness less than 2.5 mm and with a carbon content less than 0.2 per cent is considered to meet this requirement.

Structural members of the protective structure made from materials other than steel shall have equivalent low temperature impact resistance.

3.5.2.4 When testing the Charpy V-Notch impact energy requirements, the specimen size shall be no less than the largest of the sizes stated in Table 7.1 that the material will permit.

3.5.2.5 The Charpy V-Notch tests shall be made in accordance with the procedure in ASTM A 370-1979, except for specimen sizes that shall be in accordance with the dimensions given in Table 7.1.

Specimen size	Energy at	
	-30 °C	-20 °C
mm	J	J <sup>b)</sup>
10 x 10 <sup>a)</sup>	11	27.5
10 x 9	10	25
10 x 8	9.5	24
10 x 7,5 <sup>a)</sup>	9.5	24
10 x 7	9	22.5
10 x 6.7	8.5	21
10 x 6	8	20
10 x 5 <sup>a)</sup>	7.5	19
10 x 4	7	17.5
10 x 3.5	6	15
10 x 3	6	15
10 x 2.5 <sup>a)</sup>	5.5	14

Table 7.1  
Minimum Charpy V-notch impact energies

- a) Indicates preferred size. Specimen size shall be no less than largest preferred size that the material permits.
- b) The energy requirement at -20 °C is 2.5 times the value specified for -30 °C. Other factors affect impact energy strength, i.e. direction of rolling, yield strength, grain orientation and welding. These factors shall be considered when selecting and using steel.

3.5.2.6 Alternatives to this procedure are the use of killed or semi-killed steel for which an adequate specification shall be provided. Steel grade and quality shall be specified in accordance with ISO 630-1,2,3,4:2011-2012.

3.5.2.7 Specimens are to be longitudinal and taken from flat stock, tubular or structural sections before forming or welding for use in the protective structure. Specimens from tubular or structural sections are to be taken from the middle of the side of greatest dimension and shall not include welds.

### 3.6 *Seatbelt anchorage performance (optional)*

#### 3.6.1 Scope

Seat belts are one of the operator restraint systems used for securing the driver in motor vehicles.

This recommended procedure provides minimum performance and tests requirements for anchorage for agricultural and forestry tractors.

It applies to the anchorage of pelvic restraint systems.

#### 3.6.2 Explanation of terms used in the performance testing

3.6.2.1 The *seat belt assembly* is any strap or belt device fastened across the lap or pelvic girdle area designed to secure a person in a machine.

3.6.2.2 The *extension belt* is intended as any strap, belt, or similar device that aids in the transfer of seat belt loads.

3.6.2.3 The *anchorage* is intended as the point where the seat belt assembly is mechanically attached to the seat system or tractor.

3.6.2.4 The *seat mounting* is intended as all intermediary fittings (such as slides, etc.) used to secure the seat to the appropriate part of the tractor.

3.6.2.5 The *Operator Restraint System* is intended as the total system composed of seat belt assembly, seat system, anchorages and extension which transfers the seat belt load to the tractor.

3.6.2.6 *Applicable Seat Components* comprise all components of the seat whose mass could contribute to loading of the seat mounting (to the vehicle structure) during a roll-over event.

#### 3.6.3 Test procedure

The procedure is applicable to a seat belt anchorage system provided for a driver or a person in addition to the driver carried by the tractor.

Only static tests for anchorages are given in this procedure.

If, for a given protective structure, a manufacturer provides more than one seat with identical components which transfer the load from the seatbelt anchorage, to the seat mounting on the ROPS floor or tractor chassis, the Testing Station is authorized to test only one configuration, corresponding to the heaviest seat.

The seat shall be in position during the tests and fixed to the mounting point on the tractor using all intermediary fittings (such as suspension, slides, etc.) specified for the complete tractor. No additional non-standard fittings contributing to the strength of the construction may be used.

The worst case loading scenario for seat belt anchorage performance testing should be identified with consideration to the following points:-

- If the masses of alternative seats are comparable, those featuring seat belt anchorages which transfer loading through the seat structure (*e.g. via the suspension system and/or adjustment slides*), will be required to withstand much higher test loading. They are therefore likely to represent the worst case;
- If the applied loading will pass through the seat mountings to the vehicle chassis, the seat should be adjusted longitudinally to achieve the minimum amount of overlap of the mounting slides / rails. This will usually be when the seat is in the fully-rearward position but, if certain vehicle installations limit seat rearward travel, the fully-forward seat position may provide the worst case loading position. Observation of the amount of seat movement and mounting slide / rail overlap is required.

The anchorages shall be capable of withstanding the loads applied to the seat belt system using a device as shown in Figure 7.8. The seat belt anchorages shall be capable of these test loads applied with the seat adjusted in the worst position of the longitudinal adjustment to ensure that the test condition is met. The test loads shall be applied with the seat in the mid-position of the longitudinal adjustment if a worst position among the possible seat adjustments is not recognised by the testing station. For a suspended seat, the seat shall be set to the midpoint of the suspension travel, unless this is contradictory to a clearly stated instruction by the seat manufacturer. Where special instructions exist for the seat setting, these shall be observed and specified in the report.

After the load is applied to the seat system, the load application device shall not be repositioned to compensate for any changes that may occur to the load application angle.

#### 3.6.3.1 Forward loading

A tensile force shall be applied in a forward and upward direction at an angle of  $45^\circ \pm 2^\circ$  to the horizontal, as shown in Figure 7.9. The anchorages shall be capable of withstanding a force of 4 450 N. In the event that the force applied to the seat belt assembly is transferred to the vehicle chassis by means of the seat, the seat mounting shall be capable of withstanding this force plus an additional force equal to four times the force of gravity on the mass of all applicable seat components, applied  $45^\circ \pm 2^\circ$  to the horizontal in a forward and upward direction, as shown in Figure 7.9.

#### 3.6.3.2 Rearward loading

A tensile force shall be applied in a rearward and upward direction at an angle of  $45^\circ \pm 2^\circ$  to the horizontal, as shown in Figure 7.10. The anchorages shall be capable of withstanding a force of 2 225 N. In the event that the force applied to the seat belt assembly is transferred to the vehicle chassis by means of the seat, the seat mounting shall be capable of withstanding this force plus an additional force equal to two times the force of gravity on the mass of all applicable seat components, applied  $45^\circ \pm 2^\circ$  to the horizontal in a rearward and upward direction, as shown in Figure 7.10.

Both tensile forces shall be equally divided between the anchorages.

#### 3.6.3.3 Seatbelt buckle release force (if required by the manufacturer)

The seat belt buckle shall open with a maximum force of 140 N following the load applications. This requirement is fulfilled for seat belt assemblies that satisfy the requirements of UN-ECE R-16 or Directive 77/541/EEC as last amended.

#### 3.6.4. Test result

Condition of acceptance

Permanent deformation of any system component and anchorage area is acceptable under the action of the forces specified in 3.6.3.1 and 3.6.3.2. However, there shall be no failure allowing release of the seat belt system, seat assembly, or the seat adjustment locking mechanism.

The seat adjuster or locking device need not be operable after application of the test load.

The results of a test performed on an identical “operator restraint system” may be included in more than one test report provided that this system is fitted exactly in the same conditions. The results of a test performed after the approval of the test report of the protective structure shall be drafted in a technical extension report.

### **3.7 Foldable ROPS performance (optional)**

#### 3.7.1 Scope

This recommended procedure provides minimum performance and tests requirements for rear mounted foldable ROPS

- raised and/or lowered manually by a standing operator (with or without partial assistance).
- locked manually or automatically.

#### 3.7.2 Explanation of terms used in the performance testing:

3.7.2.1 hand-operated foldable ROPS is a rear-mounted dual pillar protective structure with hand raising/lowering directly managed by the operator (with or without partial assistance).

3.7.2.2 automatic foldable ROPS is a rear-mounted dual pillar protective structure with full assisted raising/lowering operations.

3.7.2.3 locking system is a device fitted to lock, by hand or automatically, the ROPS in the raised or lowered positions.

3.7.2.4 grasping area is defined by the manufacturer as a portion of the ROPS and/or additional handle fitted to the ROPS where the operator is allowed to carry out the raising/lowering operations.

3.7.2.5 accessible part of the grasping area is intended as the area where the ROPS is handled by the operator during the raising/lowering operations. This area shall be defined with regard to the geometric centre of cross sections of the grasping area.

3.7.2.6 accessible zone is the volume where a standing operator can apply a force in order to raise/lower the ROPS.

3.7.2.7 pinching point is a dangerous point where parts move in relation to each other or to fixed parts in such a way as may cause persons or certain parts of their bodies to be pinched.

3.7.2.8 shear point is a dangerous point where parts move along each other or along other parts in such a way as may cause persons or certain parts of their bodies to be pinched or shorn.

3.7.2.9 place to stand is a place on the tractor platform accessible from the driving position main access with sufficient space for a standing operator.

### 3.7.3 Hand-operated foldable ROPS

#### 3.7.3.1 Prior conditions for the test

##### 3.7.3.1.1 Grasping area

The manual handling shall be done by a standing operator with one or more grasps on grasping area of the roll-bar.

The roll-bar can be handled from the ground or from a place to stand on the platform (Figures 7.11a and 7.11b).

The operator can handle the roll-bar in parallel with or in front of its trajectory.

A multiple step process with multiple operator positions and multiple defined grasping areas is allowed.

The grasping area shall be clearly and permanently identified (Figure 7.12).

This area has to be designed without sharp edges, sharp angles and rough surfaces likely to cause injury to the operator.

This area could be on one or both sides of the tractor and could be a structural part of the roll-bar or additional handles. In this grasping area the manual handling to raise or lower the roll-bar shall not create shearing, pinching or uncontrollable movement hazards to the operator.

##### 3.7.3.1.2 Accessible zones

Three accessible zones with different amount of allowed force are defined with respect to horizontal plane of the ground and the vertical planes tangent to the outer parts of the tractor that limit the position or the displacement of the operator (Figure 7.13).

Zone I: comfort zone

Zone II: accessible zone without forward leaning of the body

Zone III: accessible zone with forward leaning of the body

Handling of the roll-bar in parallel with its trajectory

The position and the movement of the operator are limited by obstacles. These are parts of the tractor and are defined by vertical planes tangent to the external edges of the obstacle.

If the operator needs to move the feet during the manual handling of the roll-bar a displacement is allowed either within a parallel plane to the roll-bar trajectory or within just one more parallel plane to the previous one so as to overcome an obstacle. The overall displacement shall be considered as a combination of straight lines parallel and perpendicular to the roll-bar trajectory. A perpendicular displacement is accepted provided that the operator comes closer to the roll-bar. The accessible area shall be considered as the envelope of the different accessible zones (Figure 7.14).

Handling of the roll-bar in front of its trajectory:

Only for handling of the roll-bar in front of its trajectory are considered as accessible extensions of the zone II and zone III (Figure 7.15). In these extensions the acceptable actuation forces are the same ones as respectively in zone II and in the zone III.

If the operator needs to move during the manual handling of the roll-bar it must be done so by a displacement without any obstacle within a plane parallel to the roll-bar trajectory.

In this case the accessible area shall be considered as the envelope of the different accessible zones.

#### 3.7.3.1.3 Place to stand

Any place to stand on the platform declared by the manufacturer shall be accessible from the main access to the driving position and fulfil the following requirements:

- A place provided for standing shall have sufficient space for both of the operator's feet, be flat and have a slip-resistant surface. Depending on the machine configuration, it may consist of two separate surfaces and may use machine components. It shall be positioned so the operator can maintain stability while carrying out the service required and be on the same height level with a tolerance of  $\pm 50$  mm.
- Handhold(s) and/or railings shall be provided in order to allow three-point contact. Parts of the machine can be considered to fulfill this requirement.

It is considered that a place for standing has sufficient space if its surface is at least a square in cross section of 400 mm per side (Figure 7.16).

Alternatively the place to stand requirement may be met by providing sufficient space for one foot on a flat surface and one knee on the seat.

#### 3.7.3.1.4 Test conditions

The tractor must be fitted with tyres having the greatest diameter indicated by the manufacturer and the smallest cross-section for tyres of that diameter. The tyres must be inflated to the pressure recommended for field work.

The rear wheels must be set to the narrowest track width; the front wheels must be set as closely as possible to the same track width. If it is possible to have two front track settings which differ equally from the narrowest rear track setting, the wider of these two front track settings must be selected.

#### 3.7.3.2 Test procedure

The aim of the test is to measure the force necessary to raise or lower the roll-bar. The test will be carried out in static condition: no initial movement of the roll-bar. Each measurement of the force necessary to raise or lower the roll-bar shall be made in a direction tangent to the trajectory of the roll-bar and passing through the geometric centre of cross sections of the grasping area.

The grasping area is considered accessible when located within the accessible zones or the envelope of different accessible zones (Figure 7.17).

The force necessary to raise and lower the roll-bar shall be measured in different points that are within the accessible part of the grasping area (Figure 7.18).

The first measure is carried out at the extremity of the accessible part of the grasping area when the roll-bar is fully lowered (Point 1).



The second measure is defined according to the position of Point 1 after rotation up to the point where the perpendicular to the trajectory of the roll-bar is vertical (Point 2).

The third measure is carried out after rotation of the roll-bar up to the top of the accessible part of the grasping area (Point 3).

If in this third measure the roll-bar is not fully raised, a point shall be measured at the extremity of the accessible part of the grasping area when the roll bar is fully raised (Point 4).

If between point 1 and point 3 the trajectory of extremity of the accessible part of the grasping area crosses the limit between Zone I and Zone II an additional measurement shall be made at this point (Figure 7.19).

The maximum forces in these points shall not exceed the acceptable force of the zone (I, II or III).

In order to measure the force in the required points, it is possible either to measure directly the value or to measure the torque needed to raise or lower the roll-bar so as to calculate the force.

### 3.7.3.3 Condition of acceptance

#### 3.7.3.3.1 Force requirement

The force acceptable for the actuation of the ROPS depends on the accessible zone as shown in Table 6.2.

Zone	I	II	III
Acceptable force (N)	100	75	50

**Table 7.2**

Allowed forces

An increase of no more than 25 % of these acceptable forces is allowed when the roll-bar is fully lowered and fully raised.

An increase of no more than 25 % of these acceptable forces is allowed if the roll-bar is handled in front of its trajectory.

An increase of no more than 50 % of these acceptable forces is allowed in the lowering operation.

#### 3.7.3.3.2 Additional requirement

The manual handling to raise or lower the roll-bar shall not create shearing, pinching or uncontrollable movement hazards to the operator.

A pinching point is not considered dangerous for the operator hands part if in the grasping area the safety distances between the roll-bar and fixed parts of the tractor are no less than 100 mm for hand, wrist, fist and 25 mm for finger (ISO 13854:2017). The safety distances shall be checked with respect to the mode of handling foreseen by the manufacturer in the operator's manual.

#### 3.7.4. Hand locking system

The device fitted to lock the ROPS in the upright/lowered position must be designed:

- to be handled by one standing operator and located in one of the accessible zones;
- to be hardly separated from the ROPS (for example captive pins as locking pins or retaining pins);
- to avoid any confusion in the locking operation (the proper location of the pins shall be indicated);
- to avoid unintentional removing or losing of parts.

If the devices employed to lock the ROPS in the upright/lowered position are pins they shall be inserted or removed freely. If to do so there is a need to apply a force on the roll-bar this shall comply with the requirements of points 1 and 3 or 4 (see 3.7.3).

For all other locking devices, they shall be engineered according to an ergonomic approach for what concerns the shape and the force specially avoiding pinching or shearing hazards.

#### 3.7.5. Preliminary test of automatic locking system

An automatic locking system fitted on hand-operated foldable ROPS has to be submitted to a preliminary test before the ROPS strength test.

The roll-bar shall be moved from the lower position to the upright locked position and back. These operations correspond to one cycle. 500 cycles shall be completed.

This could be done manually or with the use of external energy (hydraulic, pneumatic or electric actuators). In both cases the force shall be applied within a plane parallel to the trajectory of the roll-bar and passing through the grasping area, the angular speed of the roll-bar shall be roughly constant and less than 20 deg/s.

After the 500 cycles, the force applied when the roll-bar is in the upright position shall not exceed by more than 50 % the allowed force (Table 7.2).

The unlocking of the roll-bar shall be done following the operator manual.

After the completion of the 500 cycles there shall be no maintenance or adjustment on the locking system.

Note 1: The preliminary test could be applied to automatic foldable ROPS systems as well. The test should be carried out before the ROPS strength test.

Note 2: The preliminary test could be carried out by the manufacturer. In such a case the manufacturer shall provide the test station with a certificate stating that the test has been done according the test procedure and that there was no maintenance or adjustment on the locking system after the completion of the 500 cycles. The test station will check the performance of the device with one cycle from the lower position to the upright locked position and back.

Dimensions in mm

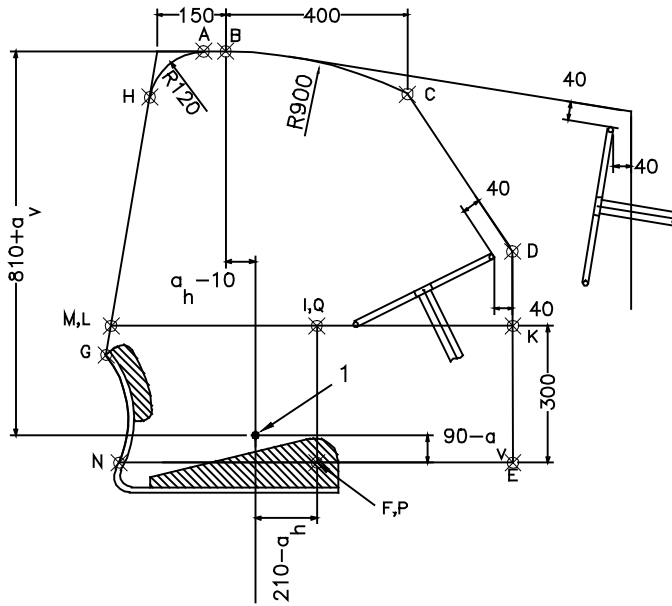

Figure 7.1.a

Side view  
Section in reference plan

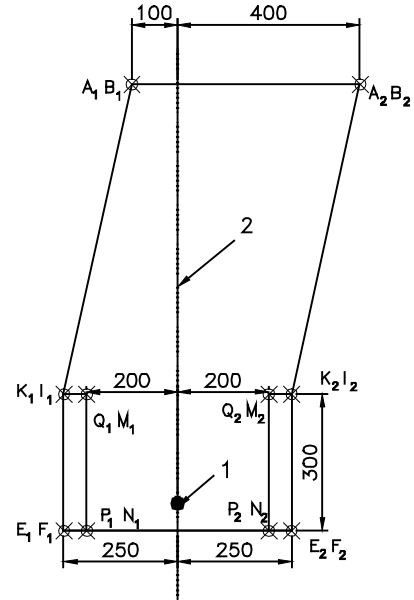

Figure 7.1.b

Rear view

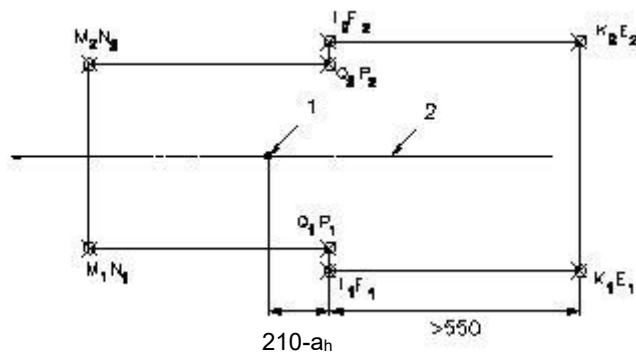

Figure 7.1.c

Seen from above

- 1 – Seat index point
- 2 – Reference plane

Figure 7.1

**Clearance zone**

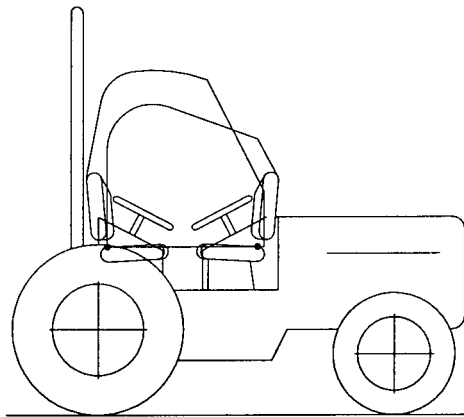

Figure 7.2.a

**Clearance zone for tractors with reversible seat position:  
two-post rollbar**

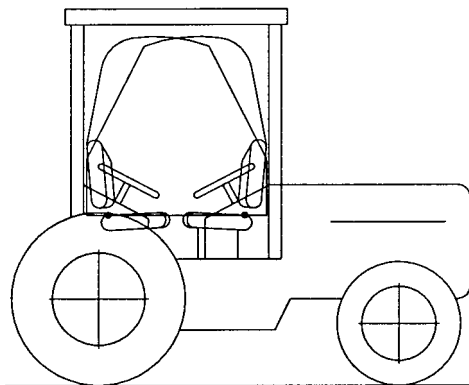

Figure 7.2.b

**Clearance zone for tractors with reversible seat position:  
other types of ROPS**

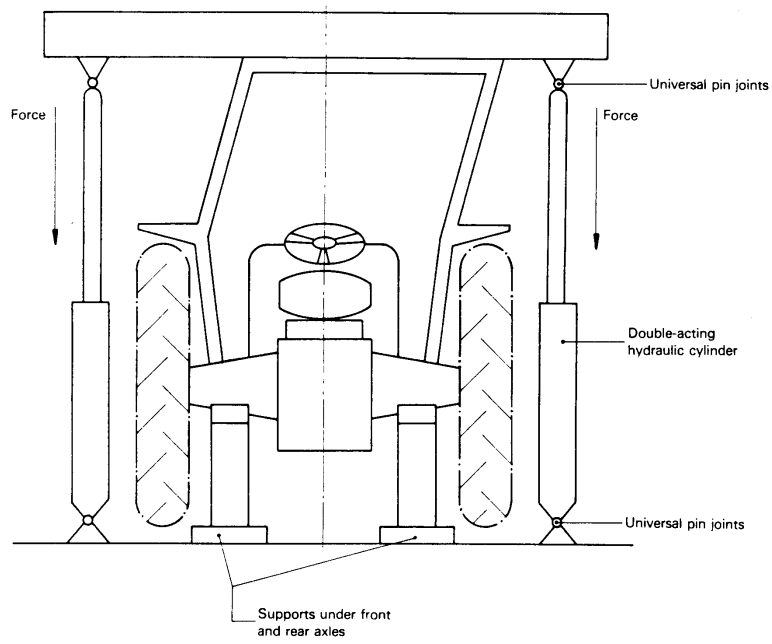
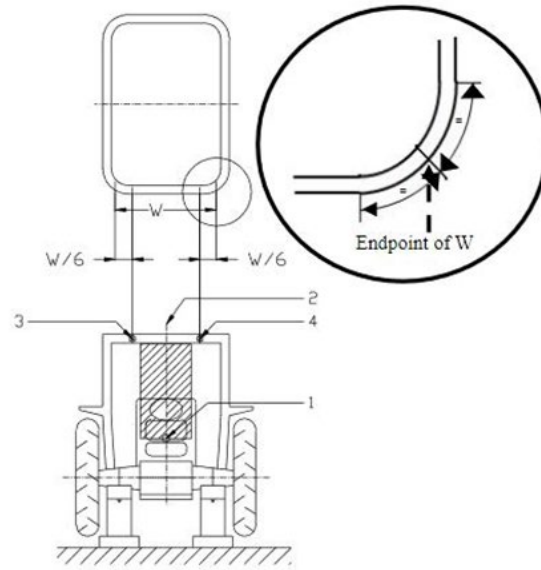

Figure 7.3

**Example of crushing rig of the tractor**



**KEY**

- 1 – Seat index point
- 2 – SIP, longitudinal centre-plane
- 3 – Point of second longitudinal load application, front or rear
- 4 – Point of longitudinal load application, rear or front

Figure 7.3 b Four-post ROPS

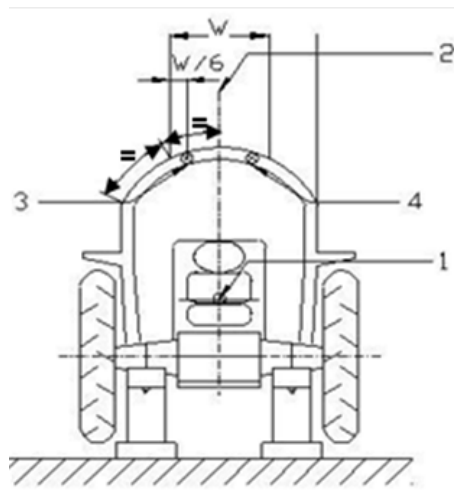
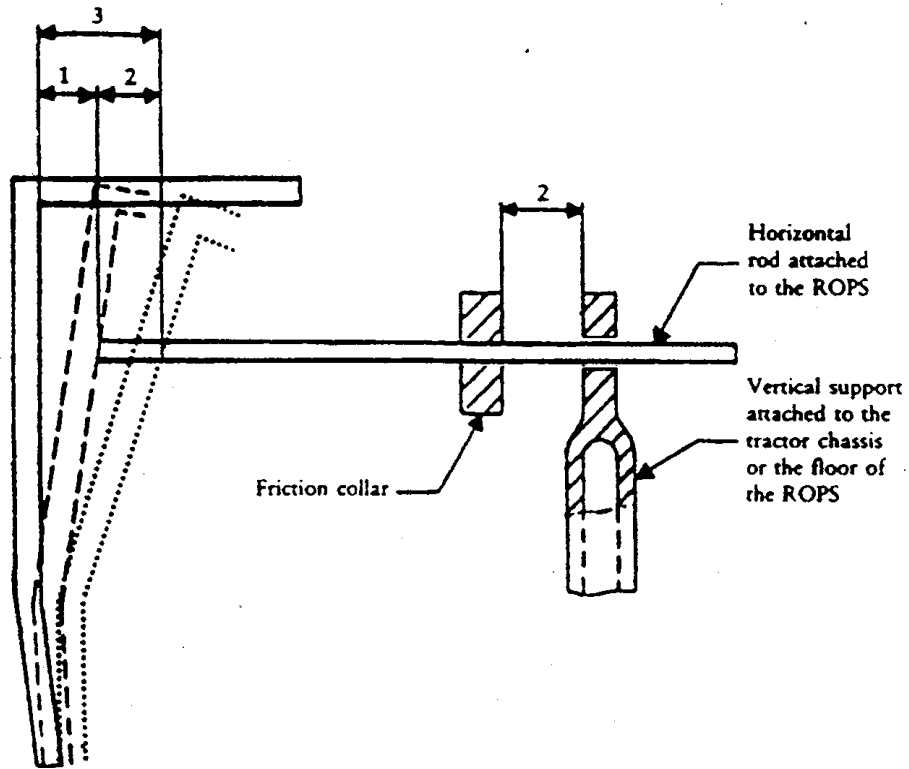

Figure 7.3 c Two-post ROPS

**KEY**

- 1 – Seat index point (SIP)
- 2 – SIP, longitudinal centre-plane
- 3 – Point of second longitudinal load application, front or rear
- 4 – Point of longitudinal load application, rear or front

**Example of ‘W’ for ROPS with curved members**



- 1 – Permanent deflection
- 2 – Elastic deflection
- 3 – Total deflection (permanent plus elastic)

Figure 7.4

**Example of apparatus for measuring elastic deflection**

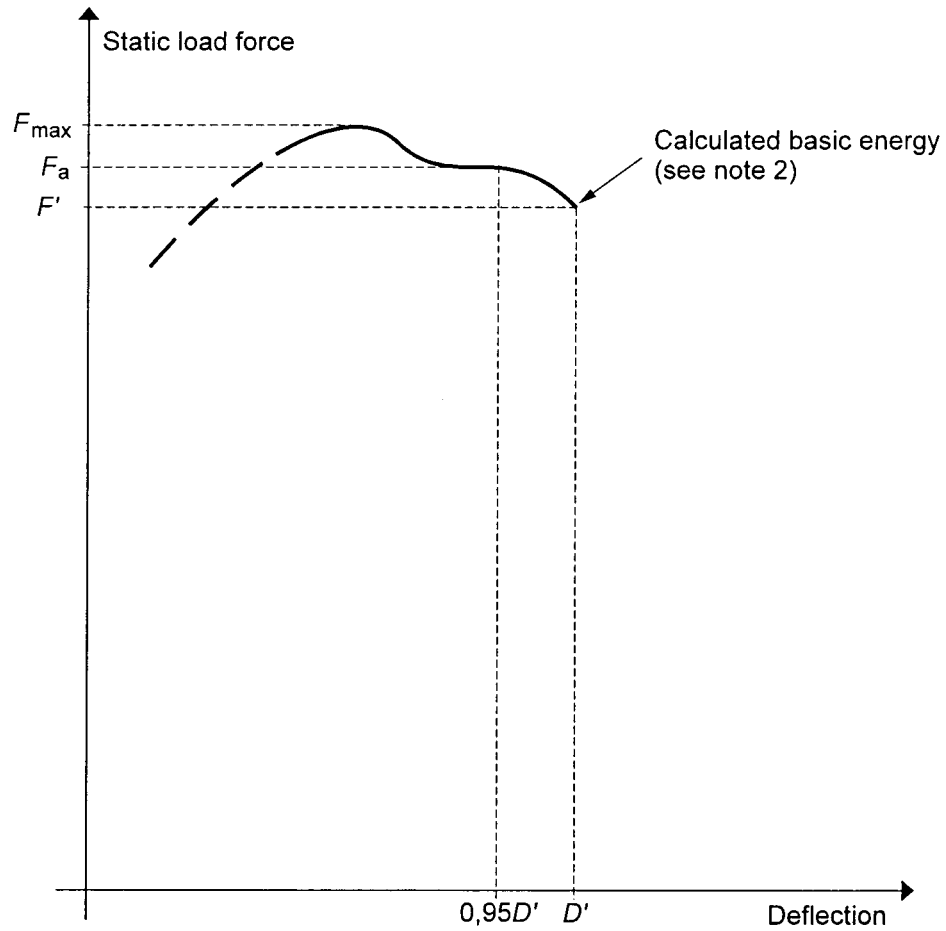

Notes:

1. Locate  $F_a$  in relation to  $0,95 D'$
2. Overload test not necessary as  $F_a \leq 1,03 F'$

Figure 7.5

**Force / deflection curve  
Overload test not necessary**



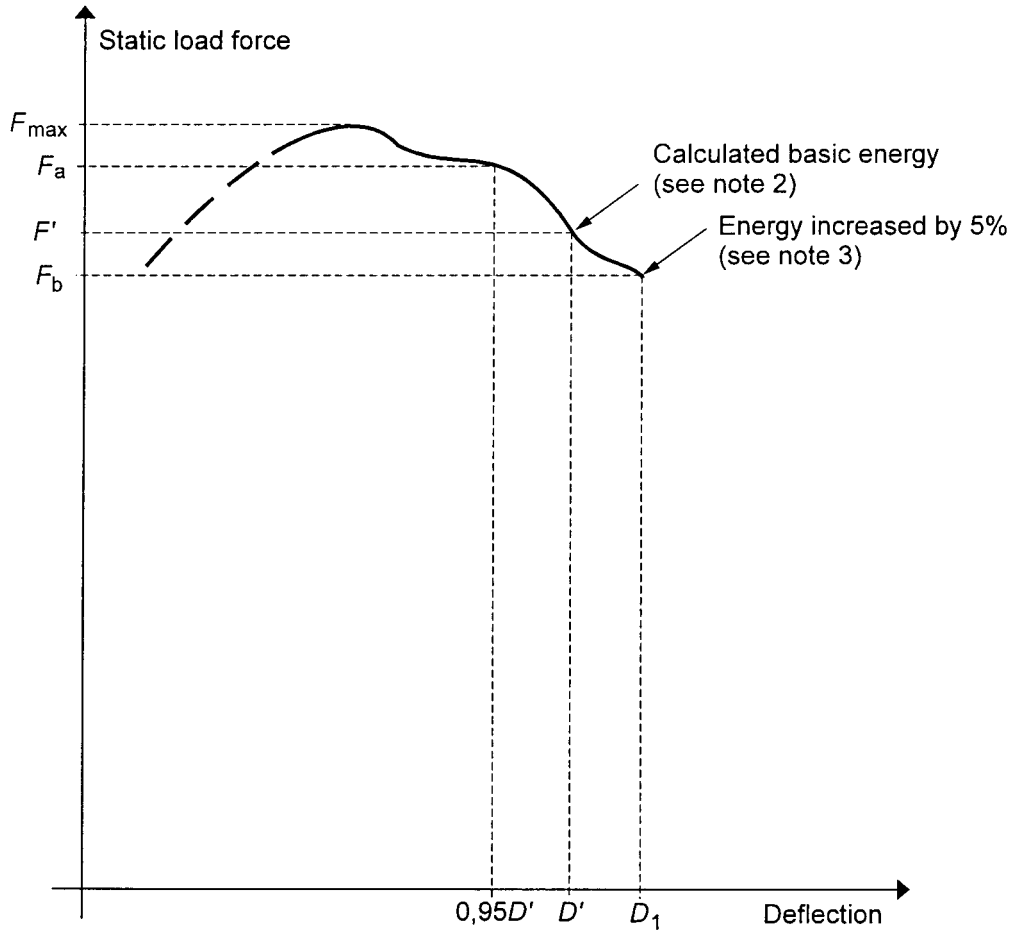

Notes:

1. Locate  $F_a$  in relation to  $0,95 D'$
2. Overload test necessary as  $F_a > 1,03 F'$
3. Overload test performance satisfactory as  $F_b > 0,97F'$  and  $F_b > 0,8F_{max}$ .

Figure 7.6

**Force / deflection curve  
Overload test necessary**

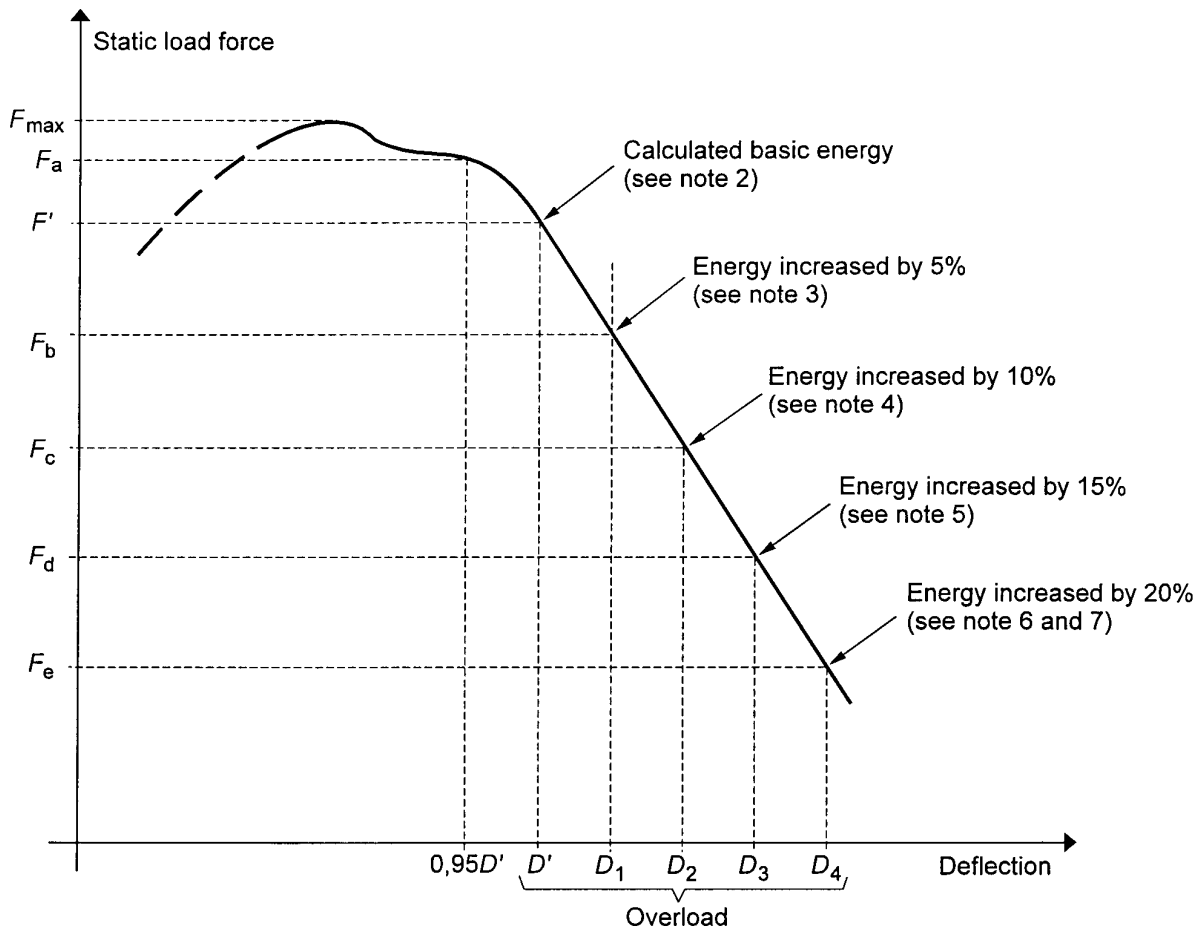

Notes:

1. Locate  $F_a$  in relation to  $0,95 D'$
2. Overload test necessary as  $F_a > 1,03 F'$
3.  $F_b < 0,97 F'$  therefore further overload necessary
4.  $F_c < 0,97 F_b$  therefore further overload necessary
5.  $F_d < 0,97 F_c$  therefore further overload necessary
6. Overload test performance satisfactory, if  $F_e > 0,8 F_{max}$
7. Failure at any stage when load drops below  $0,8 F_{max}$ .

Figure 7.7

**Force / deflection curve  
Overload test to be continued**

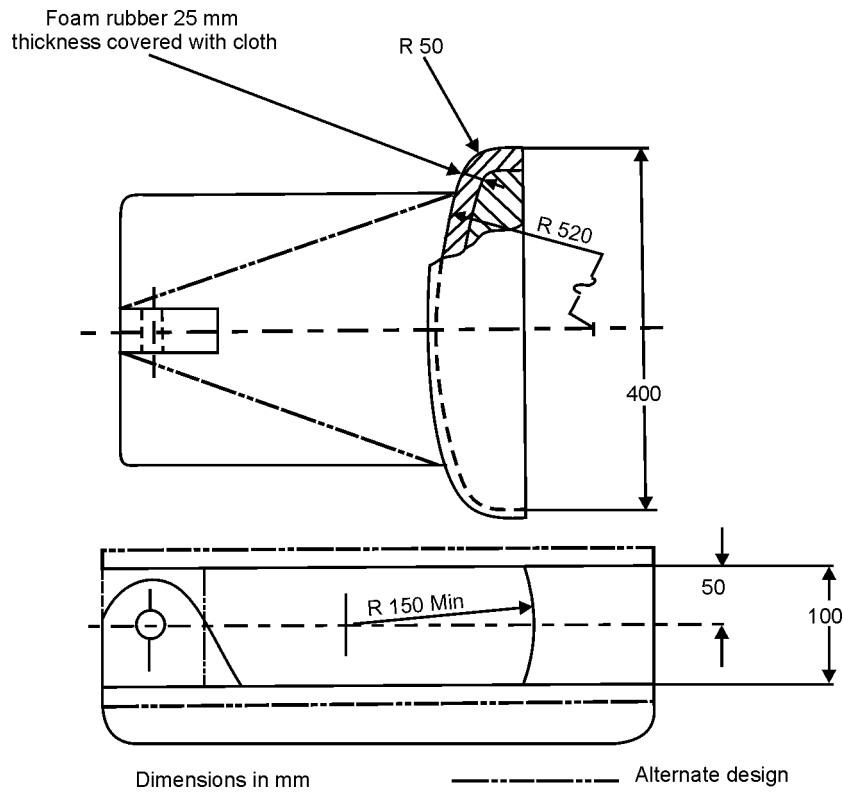

Figure 7.8

**The load application device**

Note: The dimensions not shown are optional to satisfy the test facility and do not influence the test results.

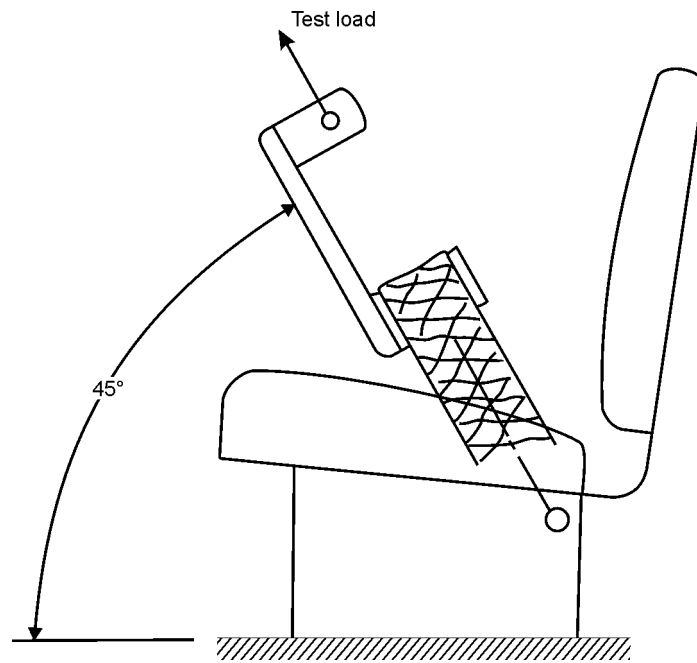

Figure 7.9

**Load application in the upward and forward direction**

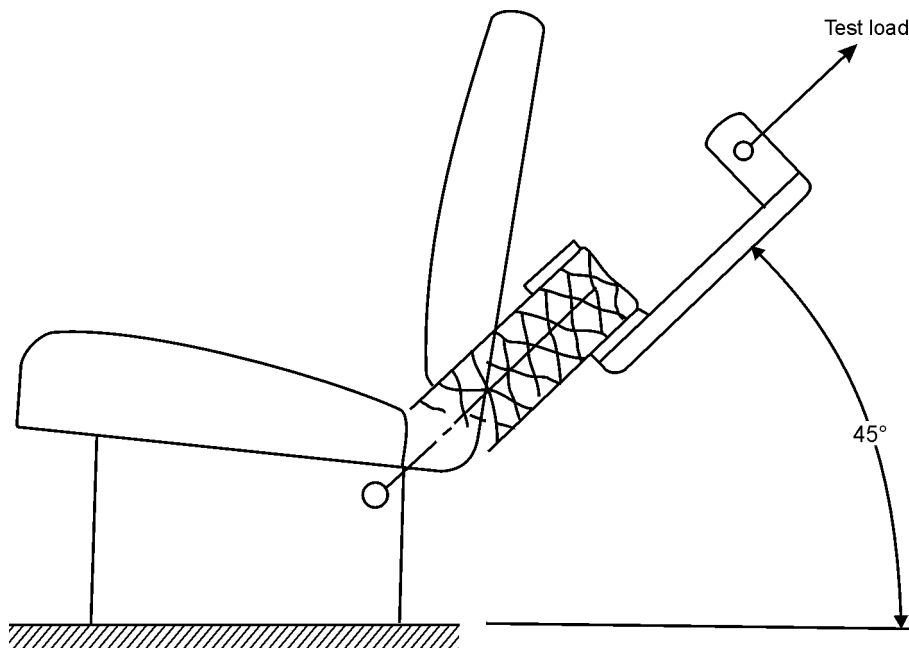
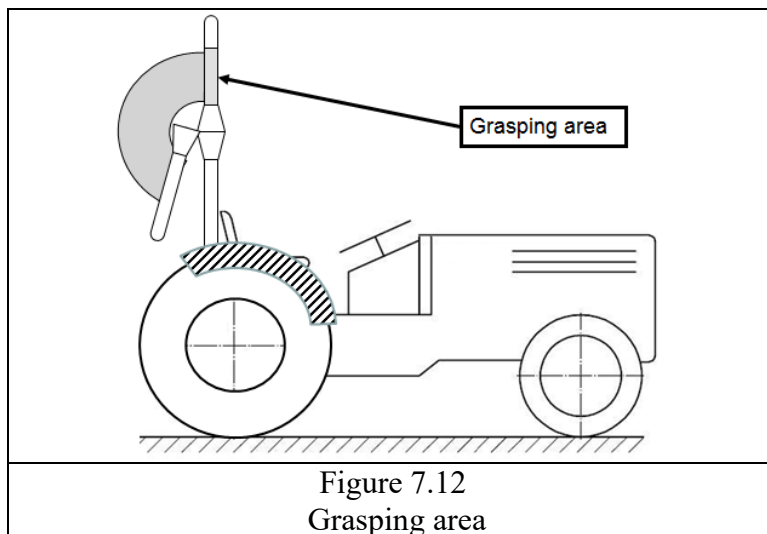
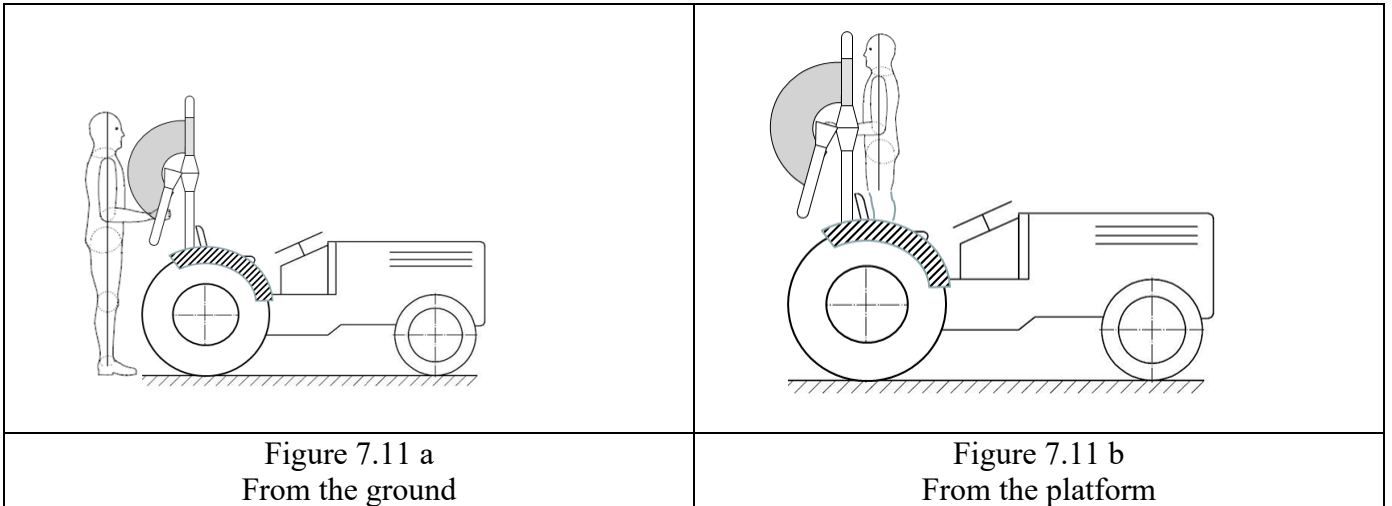
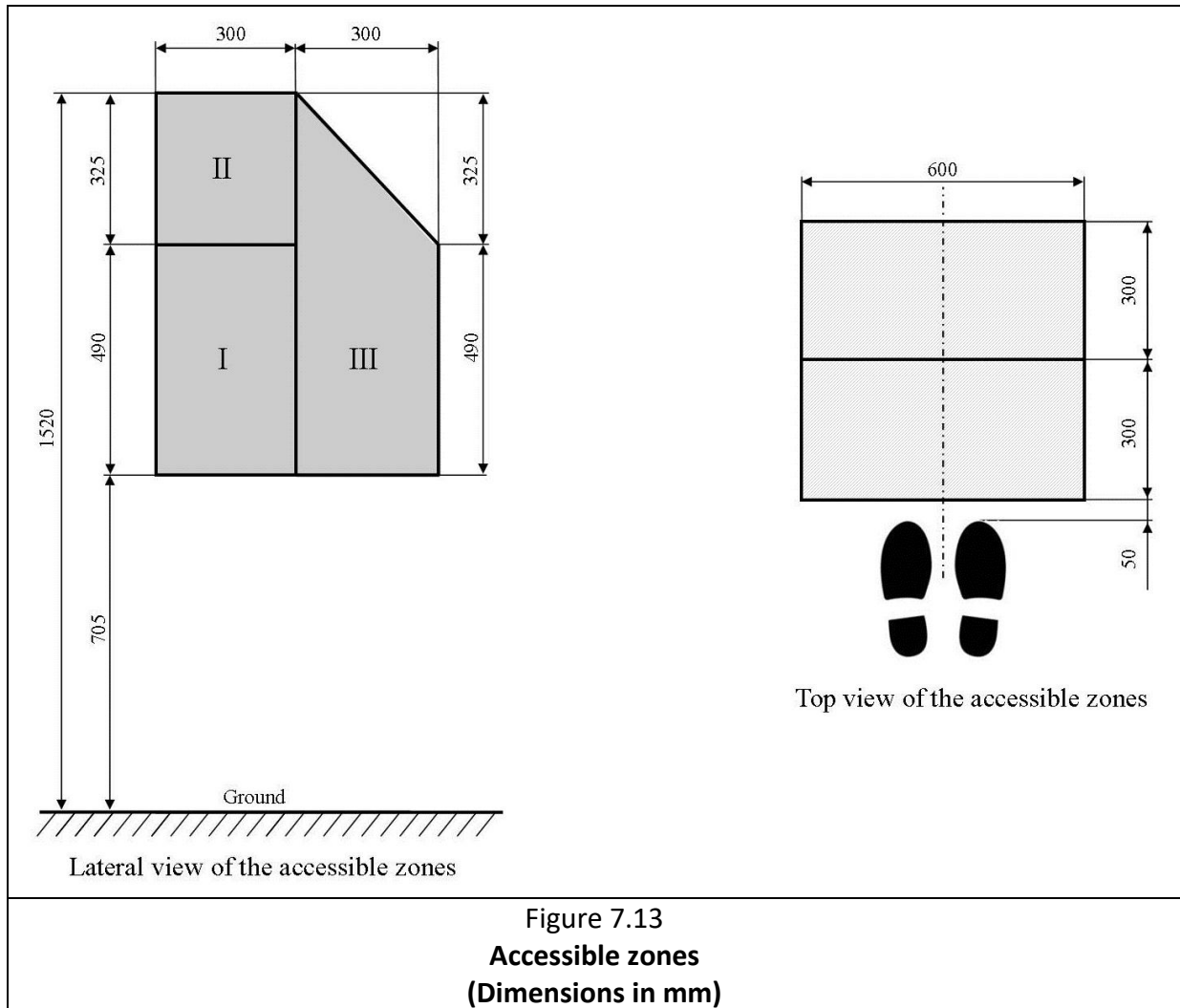
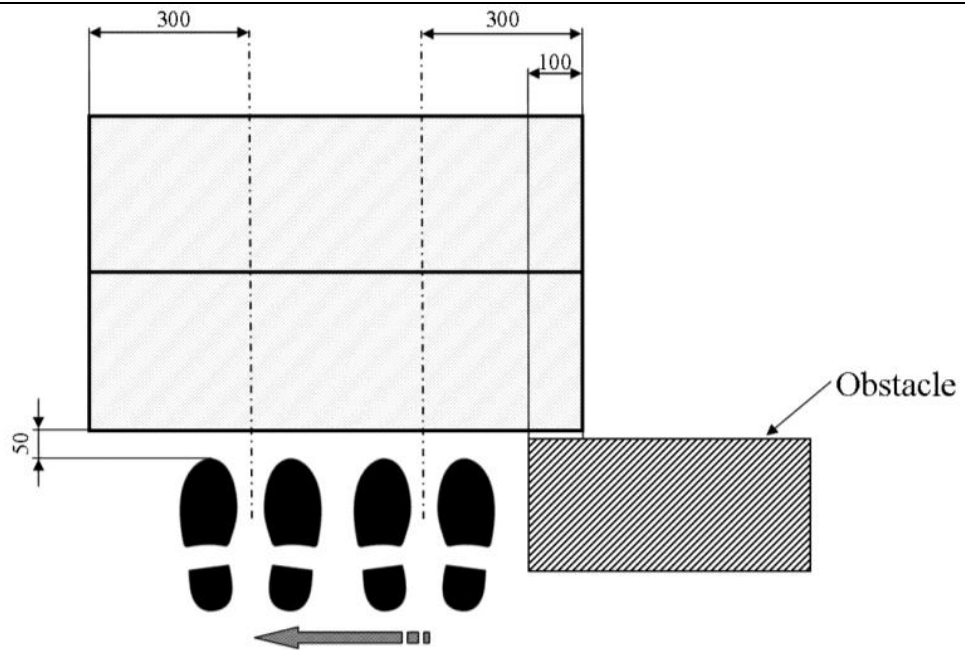

Figure 7.10

**Load application in the upward and rearward direction**







Displacement without change of direction

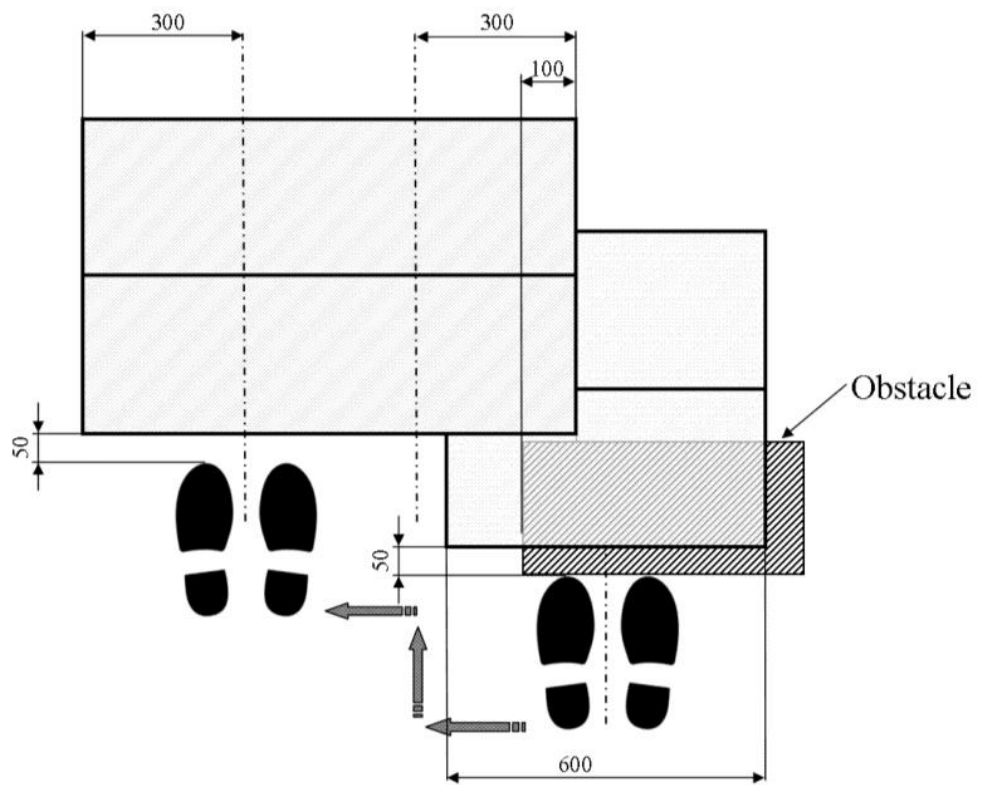

Displacement with one change of direction

Figure 7.14  
Envelope of the accessible zones  
(Dimensions in mm)

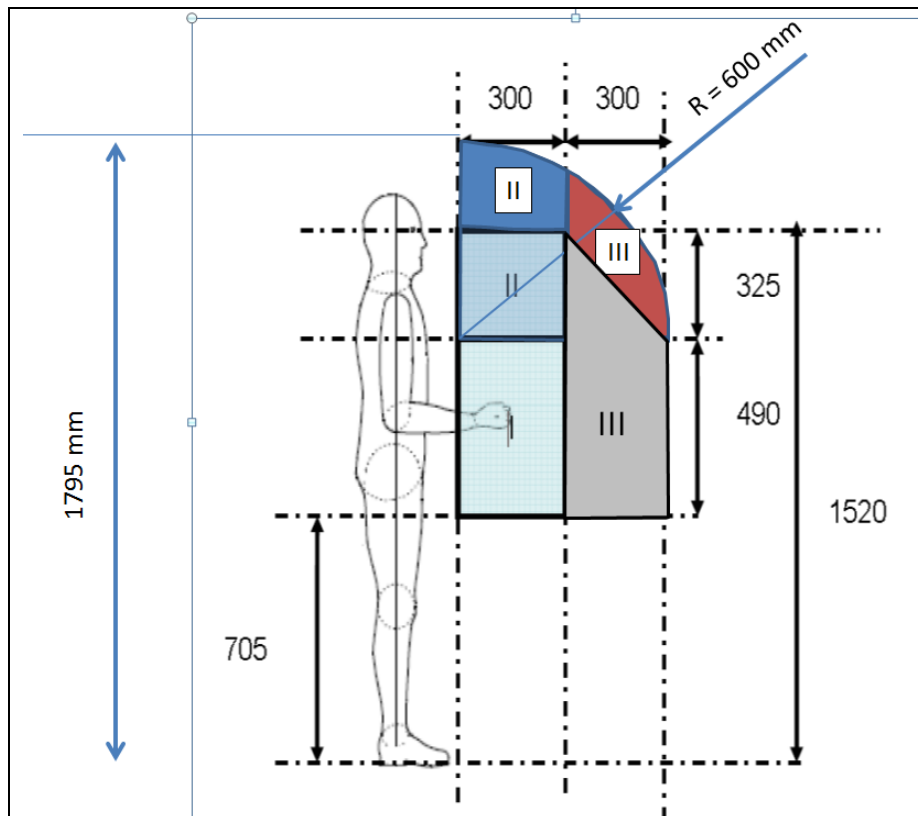

Figure 7.15  
Handling of the roll-bar in front of its trajectory.  
Accessible zones  
(Dimensions in mm)

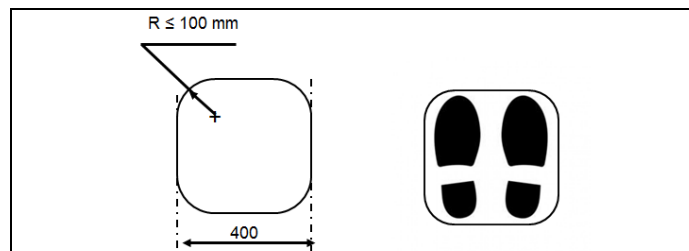

Figure 7.16  
Place to stand on the platform.



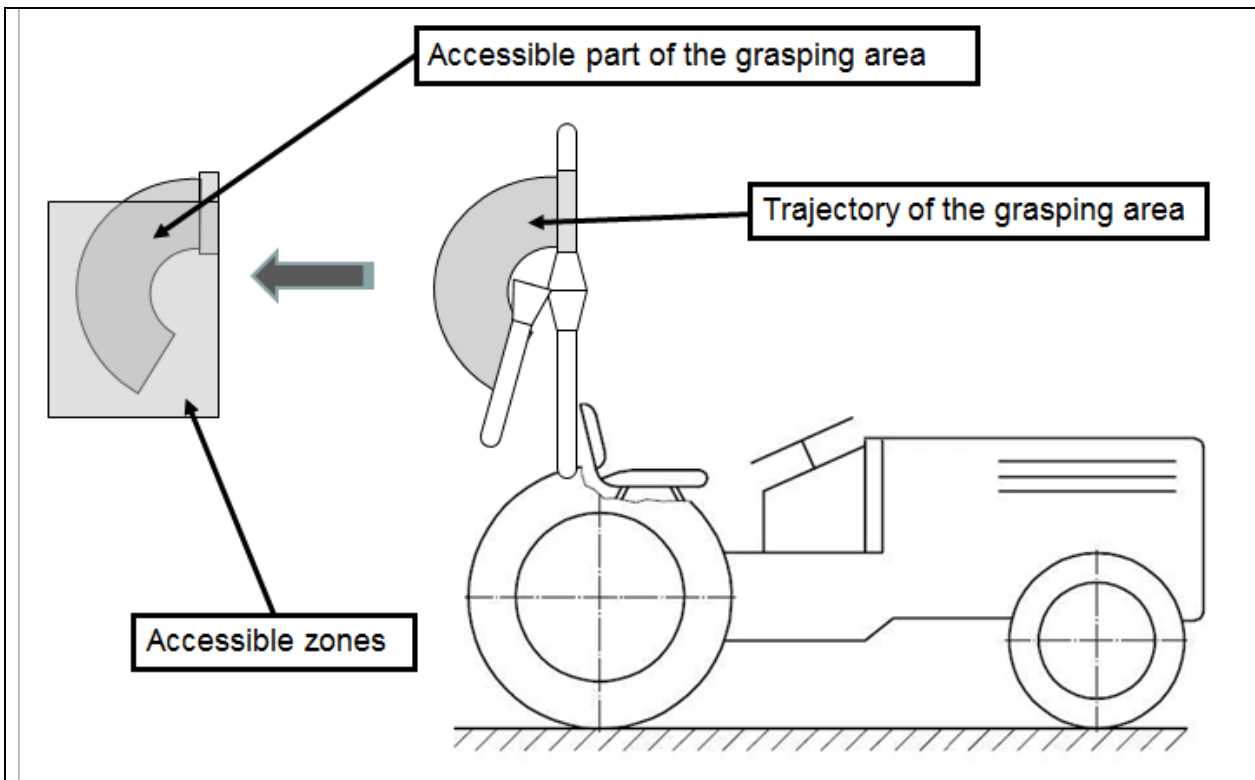

Figure 7.17  
Example of accessible part of a grasping area

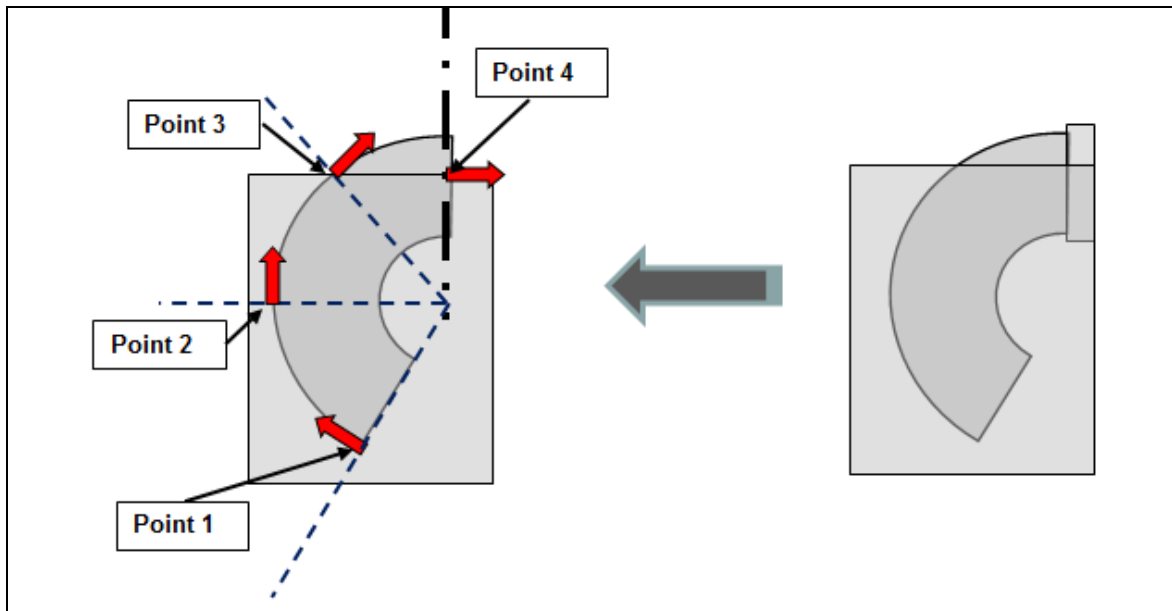

Figure 7.18  
Points where the force requirement shall be controlled

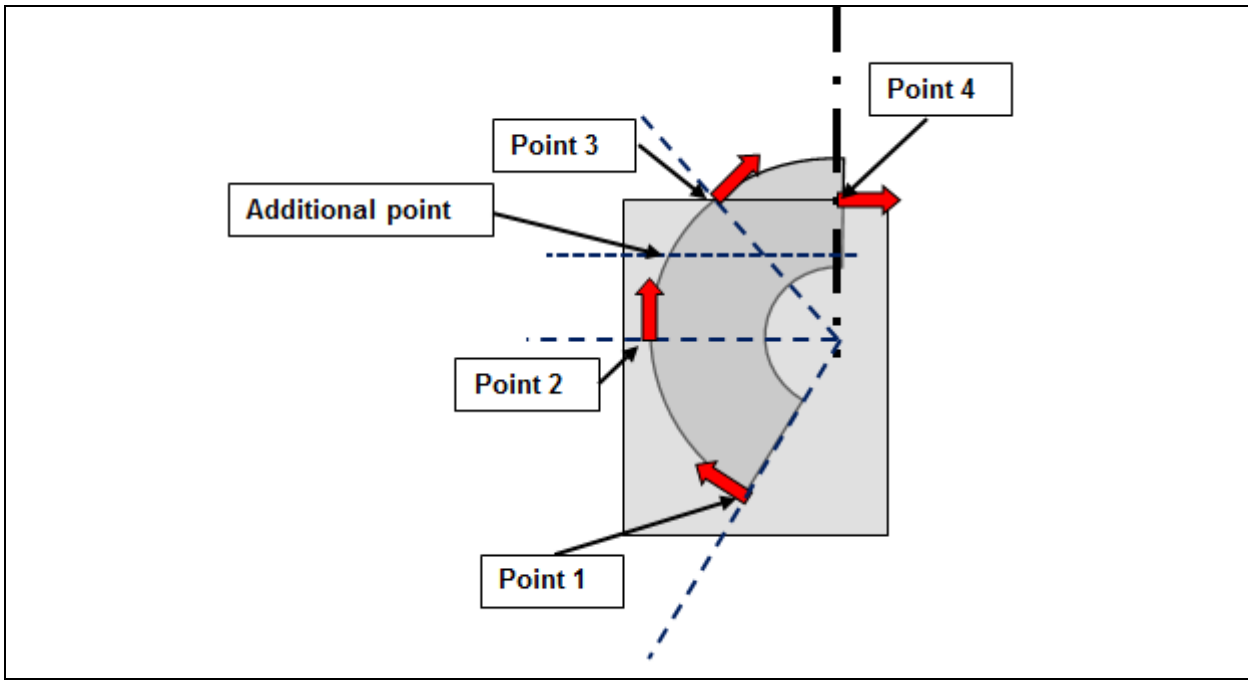

Figure 7.19  
Additional point where the force requirement shall be controlled

**SPECIMEN TEST REPORT**

**Note:** Units shown below, which appear in ISO 80000-1:2009/Cor.1:2011, shall be stated and followed by national units in parentheses, if necessary.

- Protective structure manufacturer’s name and address:
- Submitted for test by:
  
- Make of the protective structure:
- Model of the protective structure:
- Type of the protective structure: *Cab, Frame, Rear rollbar, Cab with integrated frame, etc.*
  
- Date, location of test and Code version:

**1. SPECIFICATIONS OF TEST TRACTOR**

**1.1 Identification of tractor to which the protective structure is fitted for the test**

- 1.1.1 - Make of the tractor: (\*)  
 - Model (trade name):  
 - Type: *2 WD or 4 WD; rubber or steel tracks (if applicable); articulated 4 WD or articulated 4 WD with twin (dual) wheels (if applicable)*  
 (\*) possibly different from tractor manufacturer's name

1.1.2 Numbers

- 1<sup>st</sup> Serial No. or prototype:
- Serial No.:

**1.2 Mass of unballasted tractor with protective structure fitted and without driver**

Front	kg
Rear	kg
Total	kg

- Maximum permissible mass of tractor: kg
- Reference mass used for calculating impact energies and crushing forces: kg
- Mass Ratio value - (*Maximum Permissible Mass / Reference Mass*): .....

1.3 Wheelbase/moment of inertia of the tested tractor

- Wheelbase of the tested tractor: mm
- Moment of inertia used for calculating impact energy at the rear: kgm<sup>2</sup>

**1.4 Test tyre dimensions and track settings**

	Minimum	Tyres		
	track	Dimensions	Diameter	Pressure
	mm	mm	mm	kPa
Front				
Rear				

**1.5 Tractor seats**

- Tractor with a reversible driver’s position (reversible seat and steering wheel): Yes / No
- Make/ type/ model of seat:
- Make/ type/ model of optional seat(s)  
and position(s) of the seat index point (SIP) (only for driver seats):  
(description of seat 1 and SIP position)  
(description of seat 2 and SIP position)  
(description of seat \_ and SIP position)
- Seat belt anchorage: Type
- Seat mounting on the tractor: Type
- Other seat components: Type
- Seat operating position in the test: Description

**Masses used for calculating the loads**

Seat	Make/Model/Type
COMPONENTS	MASS (kg)
Driver seat:	
Seat belt assembly:	
Other seat components:	
Total:	

**2. SPECIFICATIONS OF PROTECTIVE STRUCTURE**

**2.1 Photographs from side and rear** showing mounting details including mudguards

**2.2 General arrangement drawing of the side and the rear** of the structure including position of the seat index points (SIP), details of mountings and position of the part of front of the tractor capable of supporting the tractor when overturned (if necessary). General description of the protective structure's shape and construction (normally at least a scale of 1/20 for the general drawings and 1/2.5 for drawing of the attachments). The main dimensions must figure on the drawings, including external dimensions of tractor with protective structure fitted and main interior dimensions.

**2.3 Brief description** of the protective structure comprising:

- type of construction;
- details of mountings;
- details of cladding and padding;
- details of the front part of the tractor capable of supporting the tractor when overturned (if necessary);
- means of access and escape;
- additional frame: Yes / No.

**2.4 Tiltable/not tiltable structure**

- Tiltable / not tiltable (\*)
  - If it is necessary to tilt with any tools, this should be stated as follows:
    - Tiltable with tools/ tiltable without tools (\*)
- Folding/ not folding (\*)
  - If it is necessary to fold with any tools, this should be stated as follows:
    - Folding with tools/ folding without tools (\*)

(\*) *delete as appropriate*

**2.5 Dimensions**

Dimensions should be measured with seatpan and backrest loaded and adjusted according to Definition 1.5 of the Code.

When the tractor is fitted with different optional seats or has a reversible driver’s position (reversible seat and steering wheel), the dimensions in relation to the seat index points shall be measured in each case (SIP 1, SIP 2, etc.).

2.5.1	Height of roof members above the seat index point:	mm
2.5.2	Height of roof members above the tractor footplate:	mm
2.5.3	Interior width of the protective structure (810 + $a_v$ ) mm above the seat index point:	mm
2.5.4	Interior width of the protective structure vertically above the seat index point at the level of centre of the steering wheel:	mm
2.5.5	Distance from the centre of the steering wheel to the right-hand side of the protective structure:	mm
2.5.6	Distance from the centre of the steering wheel to the left-hand side of the protective structure:	mm
2.5.7	Minimum distance from the steering wheel rim to the protective structure:	mm

2.5.8 Horizontal distance from the seat index point to the rear of the protective structure at a height of  $(810 + a_v)$  mm above the seat index point: mm

2.5.9 Position (with reference to the rear axle) of the front part of the tractor capable of supporting the tractor when overturned (if necessary):

- horizontal distance mm
- vertical distance mm

## 2.6 Details of materials used in the construction of the protective structure and steel specifications

Steel specifications shall be in conformity with ISO 630-1,2,3,4:2011-2012.

2.6.1 Main frame: (parts - material - sizes)

- Is steel rimmed, semi-killed or killed
- steel standard and reference:

2.6.2 Mountings: (parts - material - sizes)

- Is steel rimmed, semi-killed or killed
- steel standard and reference:

2.6.3 Assembly and mounting bolts: (parts - sizes)

2.6.4 Roof : (parts - material - sizes)

2.6.5 Cladding: (parts - material - sizes)

2.6.6 Glass: (type - grade - sizes)

2.6.7 Front part of the tractor capable of supporting the tractor when overturned (if necessary) (parts - material - sizes)

## 2.7. Details of tractor manufacturer's reinforcements on original parts

**3. TEST RESULTS**

**3.1 Impact/Loading and crushing tests**

3.1.1 Conditions of tests

Impact tests/loading tests were made:

- to the rear left/right,
- to the front right/left,
- to the side right/left.

Mass used for calculating energies and loading forces: kg

Wheelbase or track used for calculating energy at the rear: mm

Moment of inertia used for calculating energy at the rear: kgm<sup>2</sup>

Energies and forces applied:

- rear: kJ
- front: kJ
- side: kJ
- crushing forces: kN
- during additional overload test: kJ

3.1.2 Permanent deflections measured after the tests

3.1.2.1 Permanent deflections of the extremities of the protective structure measured after the series of tests:

Back (forwards/backwards):

- left-hand: mm
- right-hand: mm

Front (forwards/backwards):

- left-hand: mm
- right-hand: mm

Sideways (to the left/to the right):

- front: mm
- rear: mm

Top (downwards/upwards):

- rear: mm
- left-hand mm
- right-hand: mm
- front: mm
- left-hand: mm
- right-hand: mm

3.1.2.2 Difference between total instantaneous deflection and residual deflection (elastic deflection) during:

- sideways impact test (dynamic test): mm
- or,
- sideways loading test (static test): mm

3.1.3 Indication and results of any additional test

3.1.4 Curves (static test only)

A copy of the force/deflection curves derived during the tests is included.

If a horizontal overload test was required, the reason for the overload shall be described and the additional force-deflection curves obtained during overload are included.

**Statement:**

**The acceptance conditions relative to protection of the clearance zone are fulfilled. The structure is a roll-over protective structure in accordance with the Codes.**

**3.2 Cold weather performance (resistance to brittle fracture)**

Method used to identify resistance to brittle fracture at reduced temperature:

- 
- 

Steel specifications shall be in conformity with ISO 630-1,2,3,4:2011-2012.

Steel specification: (reference and relevant standard)

**3.3 Seat belt anchorage performance**

3.3.1 Loading in the forward and upward direction

Driver seat	Make/Model/Type	
GRAVITY FORCE ( $F_g = \text{seat mass} \times 9.81$ ) N	REQUIRED FORCE ( $4450 + 4F_g$ ) N	APPLIED FORCE N

3.3.2. Loading in the rearward and upward direction

Driver seat	Make/Model/Type	
GRAVITY FORCE ( $F_g = \text{seat mass} \times 9.81$ ) N	REQUIRED FORCE ( $2225 + 2F_g$ ) N	APPLIED FORCE N

3.3.3 Curves, drawings and photos

A copy of the force/deflection curves derived during the tests shall be included.

Drawings and/or photos of the seat mounting and anchorages have to be added.



Statement (if necessary):

The testing station certifies that the tested seat is the worst variant among the seats listed below that are identical regarding the seatbelt anchorage performance test..

Statement:

During the test, no structural failure or release of seat, seat adjuster mechanism or other locking service occurred. The seat and safety belt anchorage tested fulfil the requirement of the OECD procedure.

3.4 Tractor(s) to which the protective structure is fitted

OECD Approval Number :										
Make	Model	Type	Other specifications	Mass			Tiltable	Wheel-Base	Minimum track	
				Front	Rear	Total			Front	Rear
		<i>2/4 WD, etc</i>	<i>where applicable</i>	kg	kg	kg	Yes/ No	mm	mm	

## SPECIMEN TECHNICAL EXTENSION REPORT

**Note:** Units shown below, which appear in ISO 80000-1:2009/Cor.1:2011, shall be stated and followed by national units in parentheses, if necessary.

- Protective structure manufacturer's name and address:
- Submission for extension by:
  
- Make of the protective structure:
- Model of the protective structure:
- Type of the protective structure: *Cab, Frame, Rear rollbar, Cab with integrated frame, etc.*
  
- Date, location of extension and Code version:
  
- Reference of the original test:
- Approval number and date of the original test report:
  
- Statement giving the reasons of the extension and explaining the procedure chosen (e.g. extension with validation test):

Depending on the case some of the following paragraphs may be omitted if their content is identical to the one of the original test report. It is only necessary to highlight the differences between the tractor and protective structure described in the original test report and the one for which the extension has been required.

### 1. SPECIFICATION OF TEST TRACTOR

#### 1.1 Identification of tractor to which the protective structure is fitted for the test

- 1.1.1 - Make of the tractor: (\*)  
- Model (trade name):  
- Type: *2 WD or 4 WD; rubber or steel tracks (if applicable); articulated 4 WD or articulated 4 WD with twin (dual) wheels (if applicable)*

*(\*) possibly different from tractor manufacturer's name*

- 1.1.2 Numbers
- 1<sup>st</sup> Serial No. or prototype:
  - Serial No.:

**1.2 Mass of unballasted tractor with protective structure fitted and without driver**

Front	kg
Rear	kg
Total	kg

- Maximum permissible mass of tractor: kg
- Reference mass used for calculating impact energies and crushing forces: kg
- Mass Ratio value - (*Maximum Permissible Mass / Reference Mass*): .....

**1.3 Minimum track and tyre sizes**

	Minimum track	Tyre sizes
Front	mm	
Rear	mm	

**1.4 Tractor seat**

- Tractor with a reversible driver’s position (reversible seat and steering wheel): Yes / No
- Make/ type/ model of seat:
- Make/ type/ model of optional seat(s)  
and position(s) of the seat index point (SIP) (only for driver seats):  
  - (description of seat 1 and SIP position)
  - (description of seat 2 and SIP position)
  - (description of seat \_ and SIP position)
- Seat belt anchorage: Type
- Seat mounting on the tractor: Type
- Other seat components: Type
- Seat operating position in the test: Description

**Masses used for calculating the loads**

Seat	Make/Model/Type
COMPONENTS	MASS (kg)
Driver seat:	
Seat belt assembly:	
Other seat components:	
Total:	

## 2. SPECIFICATION OF PROTECTIVE STRUCTURE

### 2.1 Photographs from side and rear showing mounting details including mudguards

2.2 **General arrangement drawing of the side and the rear** of the structure including position of the seat index points (SIP), details of mountings and position of the part of front of the tractor capable of supporting the tractor when overturned (if necessary). General description of the protective structure's shape and construction (normally at least a scale of 1/20 for the general drawings and 1/2.5 for drawing of the attachments). The main dimensions must figure on the drawings, including external dimensions of tractor with protective structure fitted and main interior dimensions.

### 2.3 Brief description of the protective structure comprising:

- type of construction;
- details of mountings;
- details of cladding and padding;
- details of the front part of the tractor capable of supporting the tractor when overturned (if necessary);
- means of access and escape;
- additional frame: Yes / No

### 2.4 Tiltable or not tiltable/ Folding or not folding structure

-- Tiltable / not tiltable (\*)

If it is necessary to tilt with any tools, this should be stated as follows:

-- Tiltable with tools/ tiltable without tools (\*)

-- Folding/ not folding (\*)

If it is necessary to fold with any tools, this should be stated as follows:

-- Folding with tools/ folding without tools (\*)

(\*) *delete as appropriate*

### 2.5 Dimensions

Dimensions should be measured with seatpan and backrest loaded and adjusted according to Definition 1.5 of the Code.

When the tractor is fitted with different optional seats or has a reversible driver's position (reversible seat and steering wheel), the dimensions in relation to the seat index points shall be measured in each case (SIP 1, SIP 2, etc.).

- |       |   |    |
|-------|---|----|
| 2.5.1 | Height of roof members above the seat index point:  | mm |
| 2.5.2 | Height of roof members above the tractor footplate:   | mm |
| 2.5.3 | Interior width of the protective structure<br>(810 + $a_v$ ) mm above the seat index point: | mm |

2.5.4	Interior width of the protective structure vertically above the seat index point at the level of centre of the steering wheel:	mm
2.5.5	Distance from the centre of the steering wheel to the right-hand side of the protective structure:	mm
2.5.6	Distance from the centre of the steering wheel to the left-hand side of the protective structure:	mm
2.5.7	Minimum distance from the steering wheel rim to the protective structure:	mm
2.5.8	Horizontal distance from the seat index point to the rear of the protective structure at a height of $(810 + a_v)$ mm above the seat index point:	mm
2.5.9	Position (with reference to the rear axle) of the front part of the tractor capable of supporting the tractor when overturned (if necessary)	
	• horizontal distance:	mm
	• vertical distance:	mm

**2.6 Details of materials used in the construction of the protective structure and specifications of steels used**

Steel specifications shall be in conformity with ISO 630-1,2,3,4:2011-2012.

2.6.1	Main frame:	(parts - material - sizes)
	• Is steel rimmed, semi-killed or killed:	
	• steel standard and reference:	
2.6.2	Mountings:	(parts - material - sizes)
	• Is steel rimmed, semi-killed or killed:	
	• steel standard and reference:	
2.6.3	Assembly and mounting bolts:	(parts - sizes)
2.6.4	Roof:	(parts - material - sizes)
2.6.5	Cladding:	(parts - material - sizes)
2.6.6	Glass:	(type - grade - sizes)
2.6.7	Front part of the tractor capable of supporting the tractor when overturned (if necessary)	(parts - material - sizes)

**2.7. Details of tractor manufacturer's reinforcements on original parts**

**3. TEST RESULTS (in case of a validation test)**

**3.1 Impact/Loading and crushing tests**

3.1.1 Condition of tests

- Loading tests were made:
  - to the rear left / right
  - to the front right / left
  - to the side right / left
  
- Mass used for calculating loading energies and crushing forces: kg
  
- Wheelbase or track used for calculating energy at the rear: mm
  
- Moment of inertia used for calculating energy at the rear: kgm<sup>2</sup>
  
- Energies and forces applied:
  - rear: kJ
  - front: kJ
  - side: kJ
  - crushing force: kN
  - during additional overload test: kJ

3.1.2 Permanent deflections measured after the tests

3.1.2.1 Permanent deflections of the extremities of the protective structure measured after the series of tests:

- Back (forwards / backwards):
  - left-hand: mm
  - right-hand: mm
  
- Front (forwards / backwards):
  - left-hand: mm
  - right-hand: mm
  
- Sideways (to the left / to the right):
  - front: mm
  - rear: mm



Dynamic test:

	Permanent deflection measured after impact test		
	original test mm	validation test mm	relative deviation %
Rear impact test			
Front impact test			
Side impact test			

If a horizontal overload test was required, the reason for the overload shall be described and the copy of additional force/deflection curves obtained during overload shall be included.

**3.2 Cold weather performance (resistance to brittle fracture)**

Method used to identify resistance to brittle fracture at reduced temperature:

- 
- 

Steel specifications shall be in conformity with ISO 630-1,2,3,4:2011-2012.

Steel specification: (reference and relevant standard)

**3.3 Seat belt anchorage performance**

3.3.1 Loading in the forward and upward direction

Driver seat	Make/Model/Type	
GRAVITY FORCE ( $F_g = \text{seat mass} \times 9.81$ ) N	REQUIRED FORCE ( $4450 + 4F_g$ ) N	APPLIED FORCE  N

3.3.2. Loading in the rearward and upward direction

Driver seat	Make/Model/Type	
GRAVITY FORCE ( $F_g = \text{seat mass} \times 9.81$ ) N	REQUIRED FORCE ( $2225 + 2F_g$ ) N	APPLIED FORCE  N



3.3.3 Curves, drawings and photos

A copy of the force/deflection curves derived during the tests shall be included.

Drawings and/or photos of the seat mounting and anchorages have to be added.

**Statement:**

**During the test, no structural failure or release of seat, seat adjuster mechanism or other locking service occurred. The seat and safety belt anchorage tested fulfil the requirement of the OECD procedure.**

3.4 Tractor(s) to which the protective structure is fitted

OECD Approval Number:										
Make	Model	Type	Other specifications	Mass			Tiltable	Wheel-Base	Minimum track	
				Front	Rear	Total			Front	Rear
		<i>2/4 WD, etc</i>	<i>where applicable</i>	kg	kg	kg	Yes/ No	mm	mm	

**SPECIMEN ADMINISTRATIVE EXTENSION REPORT**

**Note:** Units shown below, which appear in ISO 80000-1:2009/Cor.1:2011, shall be stated and followed by national units in parentheses, if necessary.

- Submitted for extension by:
- Date, location of extension and Code version:
  
- Reference of the original test:
- Approval number and date of the original test:
  
- Statement giving the reasons of the extension and explaining the procedure chosen.

**1. Specification of the protective structure**

- Frame or Cab:
- Manufacturer:
- Make:
- Model:
- Type:
- Serial Number from which modification applies:

**2. Denomination of tractor(s) to which the protective structure is fitted**

OECD Approval Number:										
Make	Model	Type	Other specifications	Mass			Tiltable	Wheel-Base	Minimum track	
				Front	Rear	Total			Front	Rear
		<i>2/4 WD, etc</i>	<i>where applicable</i>	kg	kg	kg	<i>Yes/No</i>	mm	mm	

**3. Details of modifications**

Since the original test report the following modifications have been made:

\_\_\_\_\_

\_\_\_\_\_

\_\_\_\_\_

**4. Statement**

**The modifications do not to affect the results of the original test.**

**The original test report therefore applies.**

**ANNEX I**

**CLEARANCE ZONE REFERRED TO  
THE SEAT REFERENCE POINT**

## INTRODUCTION

The paragraphs considered in the Annex refer to the definitions of the seat reference point (SRP) and the clearance zone of ROPS based on the SRP as the reference point. The numbering of the paragraphs is the same of the corresponding paragraphs in the main Code.

In the case of extension reports to test reports that originally used SRP, required measurements shall be made with reference to SRP instead of SIP. Moreover, the use of SRP shall be clearly indicated. For drafting such extension reports, the paragraphs detailed in the Annex should be followed. For the paragraphs non-reported in the Annex, previous version of Code 7 should be considered.

### 1. DEFINITIONS

#### 1.5 *Determination of seat reference point; seat location and adjustment for test*

##### 1.5.1 Seat reference point

1.5.1.1 The reference must be established by means of the apparatus illustrated in Figures 7.11, 7.12 and 7.13. The apparatus consists of a seat pan board and backrest boards. The lower backrest board is jointed in the region of the ischium humps (**A**) and loin (**B**), the joint (**B**) being adjustable in height.

1.5.1.2 The seat reference point is defined as the point in the median longitudinal plane of the seat where the tangential plane of the lower backrest and a horizontal plane intersect. This horizontal plane cuts the lower surface of the seat pan board 150 mm in front of the above-mentioned tangent.

1.5.1.3 The apparatus is positioned on the seat. It is then loaded with a force of 550 N at a point 50 mm in front of joint (**A**), and the two parts of the backrest board lightly pressed tangentially against the backrest.

1.5.1.4 If it is not possible to determine definite tangents to each area of the backrest (above and below the lumbar region), the following steps must be taken:

- where no definite tangent to the lower area is possible, the lower part of the backrest board is pressed against the backrest vertically;
- where no definite tangent to the upper area is possible, the point (**B**) is fixed at a height of 230 mm above the lower surface of the seat pan board, the backrest board being perpendicular to the seat pan board. Then the two parts of the backrest board are lightly pressed against the backrest tangentially.

##### 1.5.2 Seat location and adjustment for test

1.5.2.1 Where the seat position is adjustable, the seat must be adjusted to its rear uppermost position;

1.5.2.2 where the inclination of the backrest and seat pan is adjustable, these must be adjusted so that the reference point is in its rear uppermost position;

1.5.2.3 where the seat is equipped with suspension, the latter must be blocked at mid-travel, unless this is contrary to the instructions clearly laid down by the seat manufacturer;

1.5.2.4 where the position of the seat is adjustable only lengthwise and vertically, the longitudinal axis passing through the seat reference point shall be parallel with the vertical longitudinal plane of the tractor passing through the centre of the steering wheel and not more than 100 mm from that plane.

## 1.6 Clearance zone

### 1.6.1 Vertical reference plane

The clearance zone (Figures 7.14, 7.15 and 7.16) is defined on the basis of a vertical reference plane generally longitudinal to the tractor and passing through the seat reference point and the centre of the steering wheel; normally, the vertical reference plane coincides with the median plane of the tractor. This plane must be able to move horizontally with the seat and the steering wheel during impacts and loads, but to remain perpendicular to the floor of the tractor or of the protective structure if this is resiliently mounted.

### 1.6.2 Determination of clearance zone

The zone is bounded by the following planes, the tractor being on a horizontal surface and, where the steering wheel is adjustable, its position adjusted for normal seated driving:

1.6.2.1 a horizontal plane  $A_1 B_1 B_2 A_2$  900 mm above the seat reference point;

1.6.2.2 an inclined plane  $H_1 H_2 G_2 G_1$  perpendicular to the vertical reference plane and including a point 900 mm directly above the seat reference point and the rearmost point of the seat backrest;

1.6.2.3 a cylindrical surface  $A_1 A_2 H_2 H_1$  which is perpendicular to the reference plane, has a radius of 120 mm and is tangential to the planes defined above in 1.6.2.1 and 1.6.2.2;

1.6.2.4 a cylindrical surface  $B_1 C_1 C_2 B_2$  perpendicular to the reference plane, having a radius of 900 mm and extending forward by 400 mm the plane defined in 1.6.2.1 above, to which it is tangential, following a horizontal line 150 mm forward of the seat reference point;

1.6.2.5 an inclined plane  $C_1 D_1 D_2 C_2$  perpendicular to the reference plane, extending the surface defined in 1.6.2.4 above and passing through a point 40 mm from the outer edge of the steering wheel;

1.6.2.6 a vertical plane  $D_1 K_1 E_1 E_2 K_2 D_2$  perpendicular to the reference plane and passing 40 mm in front of the other edge of the steering wheel;

1.6.2.7 a horizontal plane  $E_1 F_1 P_1 N_1 N_2 P_2 F_2 E_2$  passing through the seat reference point;

1.6.2.8 a curvilinear surface  $G_1 L_1 M_1 N_1 N_2 M_2 L_2 G_2$  perpendicular to the reference plane and in contact with the back of the seat backrest;

1.6.2.9 two vertical planes  $K_1 I_1 F_1 E_1$  and  $K_2 I_2 F_2 E_2$  parallel to the reference plane, 250 mm either side of this plane, and bounded towards the top 300 mm above the horizontal plane passing through the seat reference point;

1.6.2.10 two inclined and parallel planes  $A_1 B_1 C_1 D_1 K_1 I_1 L_1 G_1 H_1$  and  $A_2 B_2 C_2 D_2 K_2 I_2 L_2 G_2 H_2$  starting from the upper edge of the planes defined in 1.6.2.9 above and joining the horizontal plane defined in 1.6.2.1 above at least 100 mm from the reference plane on the side where the impact is applied;

1.6.2.11 two portions of vertical planes  $Q_1 P_1 N_1 M_1$  and  $Q_2 P_2 N_2 M_2$  parallel to the reference plane, 200 mm either side of this plane, and bounded towards the top 300 mm above the horizontal plane passing through the seat reference point;

1.6.2.12 two portions  $I_1 Q_1 P_1 F_1$  and  $I_2 Q_2 P_2 F_2$  of a vertical plane, perpendicular to the reference plane and passing 350 mm in front of the seat reference point;

1.6.2.13 two portions  $I_1 Q_1 M_1 L_1$  and  $I_2 Q_2 M_2 L_2$  of the horizontal plane passing 300 mm above the seat reference point.

### 1.6.3 Tractors with a reversible driver's position

For tractors with a reversible driver's position (reversible seat and steering wheel), the clearance zone is the envelope of the two clearance zones defined by the different positions of the steering wheel and the seat.

1.6.3.1 If the protective structure is a of a rear two-post type, for each position of the steering wheel and of the seat, the clearance zone shall respectively be defined on the basis of above sections 1.6.1 and 1.6.2 of present Code for driver's position in normal position and on the basis of sections 1.6.1 and 1.6.2 of Code 6 for driver's position in reverse position (Figure 7.17.a).

1.6.3.2 If the protective structure is of another type, for each position of the steering wheel and of the seat, the clearance zone shall be defined on the basis of sections 1.6.1 and 1.6.2 of present Code (Figure 7.17.b).

### 1.6.4 Optional seats

1.6.4.1 In case of tractors that could be fitted with optional seats, the envelope comprising the seat reference points of all the options offered shall be used during the tests. The protective structure shall not enter the larger clearance zone which takes account of these different seat reference points.

1.6.4.2 In the case where a new seat option is offered after the test has been performed, a determination shall be made to see whether the clearance zone around the new SRP falls within the envelope previously established. If it does not, a new test must be performed.

Dimensions in mm

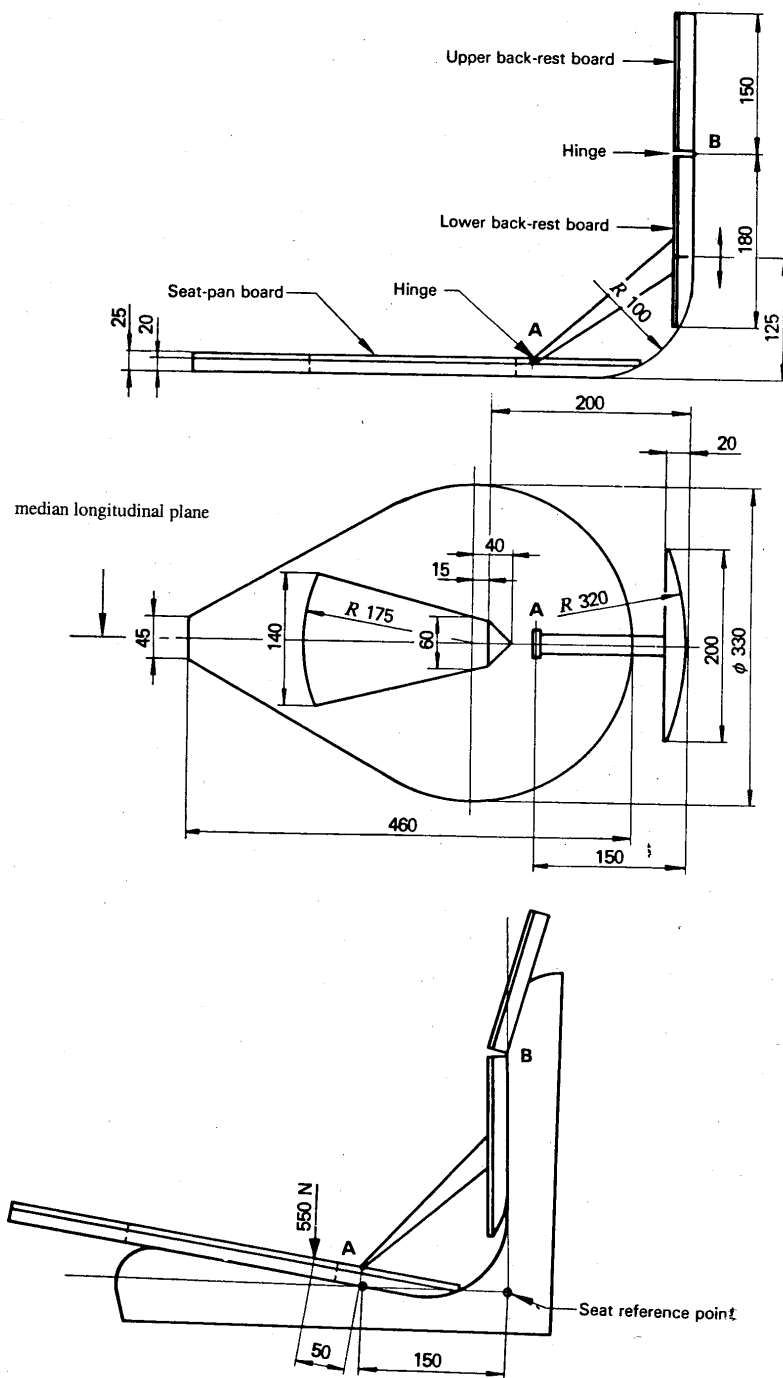

Figures 7.11, 7.12 and 7.13

**Apparatus for determination of seat reference point**

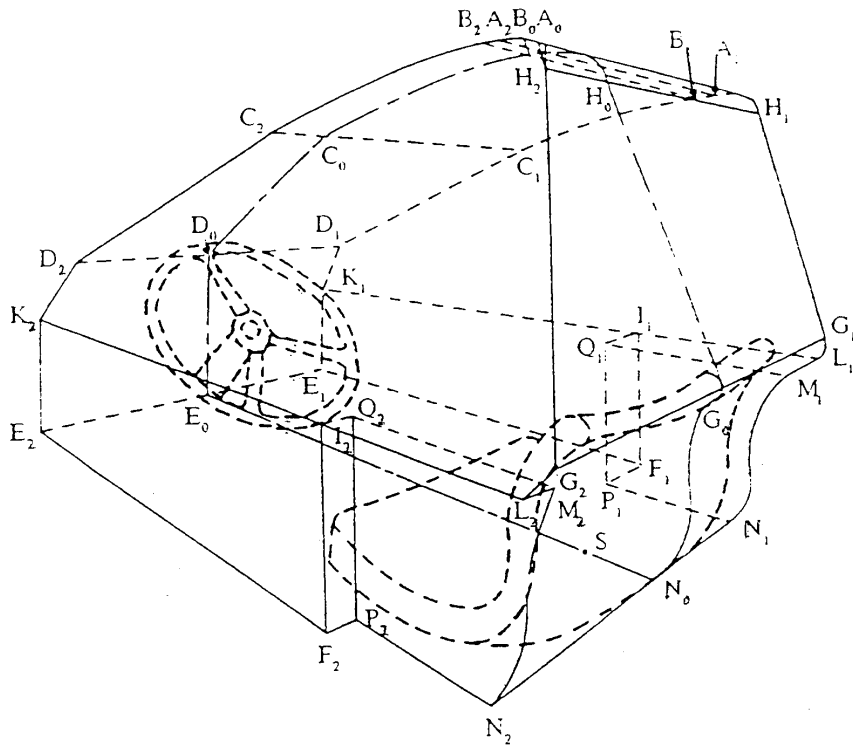

Figure 7.14  
**Clearance zone**  
 3/4 rear perspective view

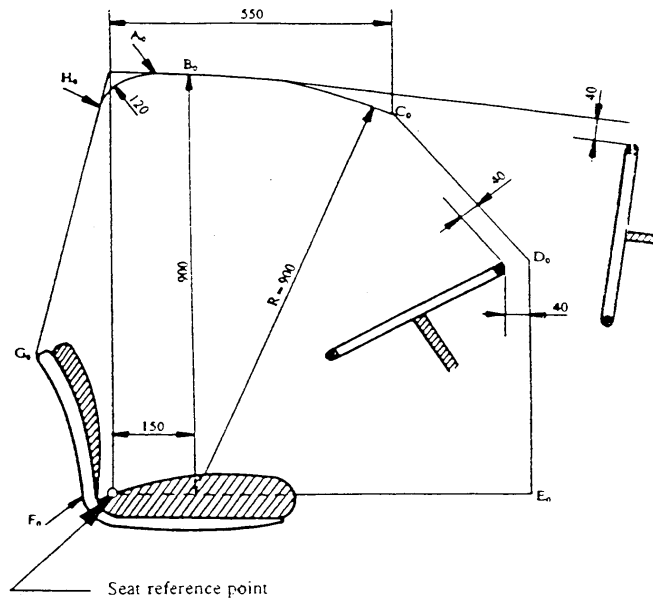
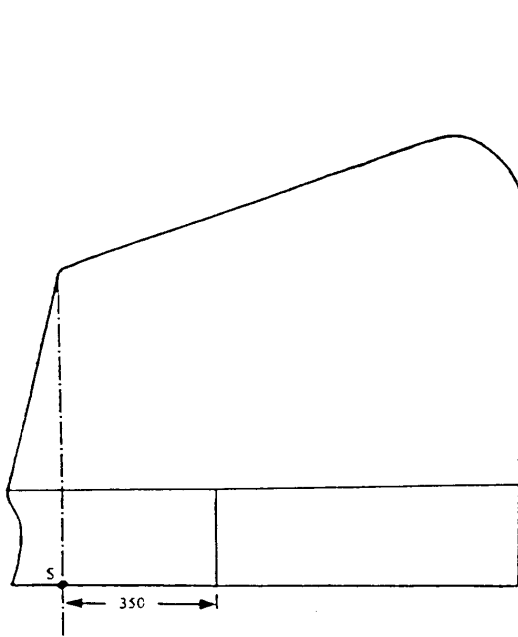

Figure 7.15  
**Clearance zone**  
 Cross-section through the reference plane





Side view

Figure 7.16.a

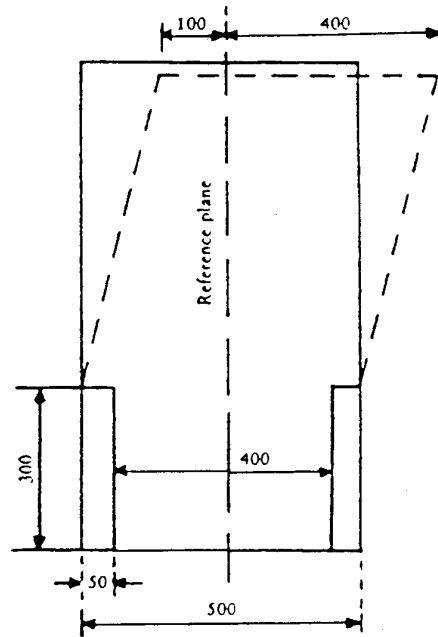

Rear view

Figure 7.16.b

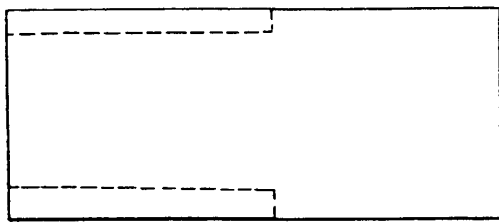

Seen from above

Figure 7.16.c

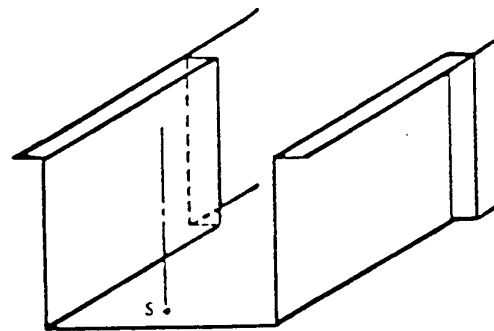

Lower part, 3/4 rear view

Figure 7.16.d

Figure 7.16  
Clearance zone

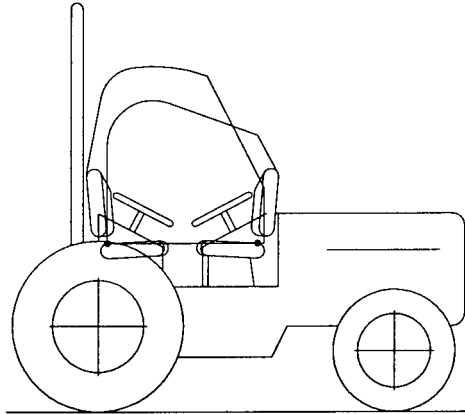

Figure 7.17.a

**Clearance zone for tractors with reversible seat position:  
two-post rollbar**

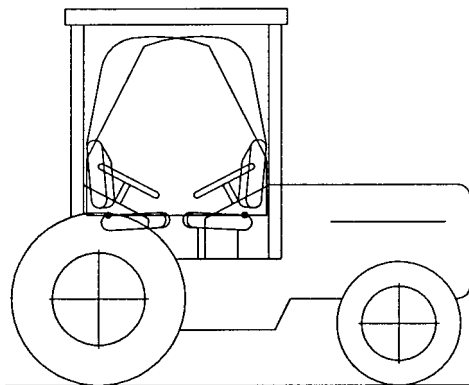

Figure 7.17.b

**Clearance zone for tractors with reversible seat position:  
other types of ROPS**

**ANNEX II**

**DYNAMIC TEST METHOD**

## INTRODUCTION

The paragraphs considered in this Annex refer to the Dynamic Testing Procedure. Tests may be performed in accordance with the dynamic or the static test procedure. The two methods are deemed equivalent. In general the numbering of the sections within this Annex relates to corresponding sections in the main Code.

### 3. RULES AND DIRECTIONS

#### 3.1 *Conditions for testing the strength of protective structures and of their attachment to tractors*

##### 3.1.1 General requirements

See requirements stated in the main Code.

##### 3.1.2 Tests

###### 3.1.2.1 Sequence of tests according to the Dynamic Procedure

The sequence of tests, without prejudice to the additional tests mentioned in sections 3.2.1.6 and 3.2.1.7 is as follows:

- (1) **impact at the rear of the structure**  
(see 3.2.1.1);
- (2) **rear crushing test**  
(see 3.2.1.4);
- (3) **impact at the front of the structure**  
(see 3.2.1.2);
- (4) **impact at the side of the structure**  
(see 3.2.1.3);
- (5) **crushing at the front of the structure**  
(see 3.2.1.5).

###### 3.1.2.2 General requirements

3.1.2.2.1 If, during the test, any part of the tractor restraining equipment breaks or moves, the test shall be restarted.

3.1.2.2.2 No repairs or adjustments of the tractor or protective structure may be carried out during the tests.

3.1.2.2.3 The tractor gear box shall be in neutral and the brakes off during the tests.

3.1.2.2.4 If the tractor is fitted with a suspension system between the tractor body and the wheels, it shall be blocked during the tests.

3.1.2.2.5 The side chosen for application of the first impact on the rear of the structure shall be that which, in the opinion of the testing authorities, will result in the application of the series of impacts

or loads under the most unfavourable conditions for the structure. The lateral impact and the rear impact shall be applied on both sides of the longitudinal median plane of the protective structure. The front impact shall be applied on the same side of the longitudinal median plane of the protective structure as the lateral impact.

### 3.1.3 Acceptance conditions

3.1.3.1 A protective structure is regarded as having satisfied the strength requirements if it fulfils the following conditions:

3.1.3.1.1 after each test it shall be free from tears or cracks, as defined in 3.2.2.1. If, significant tears or cracks appear during the test, an additional impact test or crushing test as defined in 3.2.1.6 or 3.2.1.7 must be performed immediately after the test which caused these tears or cracks to appear;

3.1.3.1.2 ;during the tests other than the overload test, no part of the protective structure must enter the clearance zone as defined in 1.6;

3.1.3.1.3 during the tests other than the overload test, all parts of the clearance zone shall be secured by the structure, in accordance with 3.2.2.2;

3.1.3.1.4 during the tests the protective structure must not impose any constraints on the seat structure;

3.1.3.1.5 the elastic deflection, measured in accordance with 3.2.2.3 shall be less than 250 mm.

3.1.3.2 There shall be no accessories presenting a hazard for the driver. There shall be no projecting part or accessory which is liable to injure the driver should the tractor overturn, or any accessory or part which is liable to trap him – for example by the leg or the foot – as a result of the deflections of the structure.

### 3.1.4 Test report

See requirements stated in the section 3.1.4 of the main Code.

### 3.1.5 Apparatus and equipment for dynamic tests

#### 3.1.5.1 Pendulum block

3.1.5.1.1 A block acting as a pendulum must be suspended by two chains or wire ropes from pivot points not less than 6 m above the ground. Means must be provided for adjusting independently the suspended height of the block and the angle between the block and the supporting chains or wire ropes.

3.1.5.1.2 The mass of the pendulum block must be  $2\,000 \pm 20$  kg excluding the mass of the chains or wire ropes which themselves must not exceed 100 kg. The length of the sides of the impact face must be  $680 \pm 20$  mm (see Figure 7.18). The block must be filled in such a way that the position of its centre of gravity is constant and coincides with the geometrical centre of the parallelepiped.

3.1.5.1.3 The parallelepiped must be connected to the system which pulls it backwards by an instantaneous release mechanism which is so designed and located as to enable the pendulum block to be released without causing the parallelepiped to oscillate about its horizontal axis perpendicular to the pendulum's plane of oscillation.

### 3.1.5.2 Pendulum supports

The pendulum pivot points must be rigidly fixed so that their displacement in any direction does not exceed 1 per cent of the height of fall.

### 3.1.5.3 Lashings

3.1.5.3.1 Anchoring rails with the requisite track width and covering the necessary area for lashing the tractor in all the cases illustrated (see Figures 7.19, 7.20 and 7.21) must be rigidly attached to a non-yielding base beneath the pendulum.

3.1.5.3.2 The tractor shall be lashed to the rails by means of wire rope with round strand, fibre core, construction 6 x 19 in accordance with ISO 2408:2017 and a nominal diameter of 13 mm. The metal strands must have an ultimate tensile strength of 1770 MPa.

3.1.5.3.3 The central pivot of an articulated tractor shall be supported and lashed down as appropriate for all tests. For the lateral impact test, the pivot shall also be propped from the side opposite the impact. The front and rear wheels or tracks need not be in line if this facilitates the attachment of the wire ropes in the appropriate manner.

### 3.1.5.4 Wheel prop and beam

3.1.5.4.1 A softwood beam of 150 mm square shall be used as a prop for the wheels during the impact tests (see Figures 7.19, 7.20 and 7.21).

3.1.5.4.2 During the lateral impact tests, a softwood beam shall be clamped to the floor to brace the rim of the wheel opposite the side of impact (see Figure 7.21).

### 3.1.5.5 Props and lashings for articulated tractors

3.1.5.5.1 Additional props and lashings must be used for articulated tractors. Their purpose is to ensure that the section of the tractor on which the protective structure is fitted is as rigid as that of a non-articulated tractor.

3.1.5.5.2 Additional specific details are given in section 3.2.1 for the impact and crushing tests.

### 3.1.5.6 Tyre pressures and deflections

3.1.5.6.1 The tractor tyres shall not be liquid-ballasted and shall be inflated to the pressures prescribed by the tractor manufacturer for field work.

3.1.5.6.2 The lashings shall be tensioned in each particular case such that the tyres undergo a deflection equal to 12 per cent of the tyre wall height (distance between the ground and the lowest point of the rim) before tensioning.

### 3.1.5.7 Crushing rig

A rig as shown in Figure 7.3 shall be capable of exerting a downward force on a protective structure through a rigid beam approximately 250 mm wide connected to the load-applying mechanism by means of universal joints. Suitable axle stands shall be provided so that the tractor tyres do not bear the crushing force.

### 3.1.5.8 Measuring apparatus

The following measuring apparatus is needed:

3.1.5.8.1 device for measuring the elastic deflection (the difference between the maximum momentary deflection and the permanent deflection, see Figure 7.4).

3.1.5.8.2 device for checking that the protective structure has not entered the clearance zone and that the latter has remained within the structure's protective during the test (see section 3.2.2.2).

## 3.2 *Dynamic test procedure*

### 3.2.1 Impact and crushing tests

#### 3.2.1.1 Impact at the rear

3.2.1.1.1 The tractor shall be so placed in relation to the pendulum block that the block will strike the protective structure when the impact face of the block and the supporting chains or wire ropes are at an angle with the vertical plane **A** equal to **M/100** with a 20° maximum, unless, during deflection, the protective structure at the point of contact forms a greater angle to the vertical. In this case the impact face of the block shall be adjusted by means of an additional support so that it is parallel to the protective structure at the point of impact at the moment of maximum deflection, the supporting chains or wire ropes remaining at the angle defined above.

The suspended height of the block shall be adjusted and necessary steps taken so as to prevent the block from turning about the point of impact.

The point of impact is that part of the protective structure likely to hit the ground first in a rearward overturning accident, normally the upper edge. The position of the centre of gravity of the block is 1/6 of the width of the top of the protective structure inwards from a vertical plane parallel to the median plane of the tractor touching the outside extremity of the top of the protective structure.

If the structure is curved or protruding at this point, wedges enabling the impact to be applied thereon must be added, without thereby reinforcing the structure.

3.2.1.1.2 The tractor must be lashed to the ground by means of four wire ropes, one at each end of both axles, arranged as indicated in Figure 7.19. The spacing between the front and rear lashing points must be such that the wire ropes make an angle of less than 30° with the ground. The rear lashings must in addition be so arranged that the point of convergence of the two wire ropes is located in the vertical plane in which the centre of gravity of the pendulum block travels.

The wire ropes must be tensioned so that the tyres undergo the deflections given in 3.1.5.6.2. With the wire ropes tensioned, the wedging beam shall be placed in front of and tight against the rear wheels and then fixed to the ground.

3.2.1.1.3 If the tractor is of the articulated type, the point of articulation shall, in addition, be supported by a wooden block at least 100 mm square and firmly lashed to the ground.

3.2.1.1.4 The pendulum block shall be pulled back so that the height of its centre of gravity above that at the point of impact is given by one of the following two formulae:

$$H = 2.165 \times 10^{-8} M L^2$$

or

$$H = 5.73 \times 10^{-2} I$$

The pendulum block is then released and strikes the protective structure.

3.2.1.1.5 For tractors with a reversible driver's position (reversible seat and steering wheel), the height shall be whichever is greater of either of the above or either of the following:

$$H = 25 + 0.07 M$$

for tractor with a reference mass of less than 2 000 kg;

$$H = 125 + 0.02 M$$

for tractor with a reference mass of more than 2 000 kg .

### 3.2.1.2 Impact at the front

3.2.1.2.1 The tractor shall be so placed in relation to the pendulum block that the block will strike the protective structure when the impact face of the block and the supporting chains or wire ropes are at an angle with the vertical plane **A** equal to **M/100** with a 20° maximum, unless, during deflection, the protective structure at the point of contact forms a greater angle to the vertical. In this case the impact face of the block shall be adjusted by means of an additional support so that it is parallel to the protective structure at the point of impact at the moment of maximum deflection, the supporting chains or wire ropes remaining at the angle defined above.

The suspended height of the pendulum block shall be adjusted and the necessary steps taken so as to prevent the block from turning about the point of impact.

The point of impact is that part of the protective structure likely to hit the ground first if the tractor overturned sideways while travelling forward, normally the upper edge. The position of the centre of gravity of the block is 1/6 of the width of the top of the protective structure inwards from a vertical plane parallel to the median plane of the tractor touching the outside extremity of the top of the protective structure.

If the structure is curved or protruding at this point, wedges enabling the impact to be applied thereon must be added, without thereby reinforcing the structure.

3.2.1.2.2 The tractor must be lashed to the ground by means of four wire ropes, one at each end of both axles, arranged as indicated in Figure 7.20. The spacing between the front and rear lashing points must be such that the wire ropes make an angle of less than 30° with the ground. The rear lashings must in addition be so arranged that the point of convergence of the two wire ropes is located in the vertical plane in which the centre of gravity of the pendulum block travels.

The wire ropes must be tensioned so that the tyres undergo the deflections given in 3.1.5.6.2. With the wire ropes tensioned, the wedging beam shall be placed behind and tight against the rear wheels and then fixed to the ground.



3.2.1.2.3 If the tractor is of the articulated type, the point of articulation shall, in addition, be supported by a wooden block at least 100 mm square and firmly lashed to the ground.

3.2.1.2.4 The pendulum block shall be pulled back so that the height of its centre of gravity above that at the point of impact is given by one of the following two formulae, to be chosen according to the reference mass of the assembly subjected to the tests:

$$H = 25 + 0.07 M$$

for tractor with a reference mass of less than 2 000 kg;

$$H = 125 + 0.02 M$$

for tractor with a reference mass of more than 2 000 kg.

The pendulum block is then released and strikes the protective structure.

3.2.1.2.5 In case of tractors with a reversible driver's position (reversible seat and steering wheel):

- if the protective structure is a rear two-post rollbar, the above formula shall apply;
- for other types of protective structure, the height shall be whichever is greater from the formula applied above and that selected below:

$$H = 2.165 \times 10^{-8} ML^2$$

or

$$H = 5,73 \times 10^{-2} I$$

The pendulum block is then released and strikes the protective structure.

### 3.2.1.3 Impact from the side

3.2.1.3.1 The tractor shall be so placed in relation to the pendulum block that the block will strike the protective structure when the impact face of the block and the supporting chains or wire ropes are vertical unless, during deflection, the protective structure at the point of contact forms an angle of less than 20° to the vertical. In this case the impact face of the block shall be adjusted by means of an additional support so that it is parallel to the protective structure at the point of impact at the moment of maximum deflection, the supporting chains or wire ropes remaining vertical on impact.

3.2.1.3.2 The suspended height of the pendulum block shall be adjusted and necessary steps taken so as to prevent the block from turning about the point of impact.

3.2.1.3.3 The point of impact shall be that part of the protective structure likely to hit the ground first in a sideways overturning accident, normally the upper edge. Unless it is certain that another part of this edge would hit ground first, the point of impact shall be in the plane at right angles to the median plane and passing 60 mm in front of the seat index point, the seat being set at the mid position of longitudinal adjustment.

3.2.1.3.4 For tractors with a reversible driver's position (reversible seat and steering wheel), the point of impact shall be in the plane at right angles to the median plane and passing at the midpoint of the segment joining the two seat index points defined by joining the two different positions of the

seat. For protective structures having a two-post system, the impact shall be located on one of the two posts.

3.2.1.3.5 The tractor wheels on the side which is to receive the impact must be lashed to the ground by means of wire ropes passing over the corresponding ends of the front and rear axles. The wire ropes must be tensioned to produce the tyre deflection values given in 3.1.5.6.2.

With the wire ropes tensioned, the wedging beam shall be placed on the ground, pushed tight against the tyres on the side opposite that which is to receive the impact and then fixed to the ground. It may be necessary to use two beams or wedges if the outer sides of the front and rear tyres are not in the same vertical plane. The prop shall then be placed as indicated in Figure 7.21 against the rim of the most heavily loaded wheel opposite to the point of impact, pushed firmly against the rim and then fixed at its base. The length of the prop shall be such that it makes an angle of  $30 \pm 3^\circ$  with the ground when in position against the rim. In addition, its thickness shall, if possible, be between 20 and 25 times less than its length and between 2 and 3 times less than its width. The props shall be shaped at both ends as shown in the details on Figure 7.21.

3.2.1.3.6 If the tractor is of the articulated type, the point of articulation shall in addition be supported by a wooden block at least 100 mm square and laterally supported by a device similar to the prop pushed against the rear wheel as in 3.2.1.3.5. The point of articulation shall then be lashed firmly to the ground.

3.2.1.3.7 The pendulum block shall be pulled back so that the height of its centre of gravity above that at the point of impact is given by one of the following two formulae, to be chosen according to the reference mass of the assembly subjected to the tests:

$$H = 25 + 0.20 M$$

for tractors with a reference mass of less than 2 000 kg;

$$H = 125 + 0.15 M$$

for tractors with a reference mass of more than 2 000 kg.

3.2.1.3.8 In case of tractors with a reversible driver's position (reversible seat and steering wheel):

- if the protective structure is a rear two-post rollbar, the selected height shall be whichever is greater from the formulae applicable above and below:

$$H = (25 + 0.20 M) (B_6 + B) / 2B$$

for tractor with a reference mass of less than 2 000 kg;

$$H = (125 + 0.15 M) (B_6 + B) / 2B$$

for tractor with a reference mass of more than 2 000 kg.

- for other types of protective structures, the selected height shall be whichever is greater from the formulae applicable above and below:

$$H = 25 + 0.20 M$$

for tractor with a reference mass less than 2 000 kg;

$$H = 125 + 0.15 M$$

for tractor with a reference mass of more than 2 000 kg.

The pendulum block is then released and strikes the protective structure.

#### 3.2.1.4 Crushing at the rear

All provisions are identical to those given in section 3.2.1.4 of the main Code.

#### 3.2.1.5 Crushing at the front

All provisions are identical to those given in section 3.2.1.5 of the main Code.

#### 3.2.1.6 Additional impact tests

If cracks or tears which cannot be considered negligible appear during an impact test, a second, similar test, but with a height of fall of:

$$H' = (H \times 10^{-1}) (12 + 4a) (1 + 2a)^{-1}$$

shall be performed immediately after the impact tests causing these tears or cracks to appear, “**a**” being the ratio of the permanent deformation (**Dp**) to the elastic deformation (**De**):

$$a = Dp / De$$

as measured at the point of impact. The additional permanent deformation due to the second impact shall not exceed 30 per cent of the permanent deformation due to the first impact.

In order to be able to carry out the additional test, it is necessary to measure the elastic deformation during all the impact tests.

#### 3.2.1.7 Additional crushing tests

If during a crushing test, significant cracks or tears appear, a second, similar, crushing test, but with a force equal to **1.2 F<sub>v</sub>** shall be performed immediately after the crushing tests which caused these tears or cracks to appear.

Additional cracks or tears or entry into or lack of protection of the clearance zone, due to elastic deformation, are permitted during the additional crushing test. After removing the load, however, the protective structure shall not infringe on the clearance zone, which shall be completely protected.

### 3.2.2 Measurements to be made

#### 3.2.2.1 Fractures and cracks

After each test all structural members, joints and fastening systems shall be visually examined for fractures or cracks, any small cracks in unimportant parts being ignored.

Any tears caused by the edges of the pendulum weight are to be ignored.

#### 3.2.2.2 Entry into the clearance zone

During each test the protective structure shall be examined to see whether any part it has entered a clearance zone round the driving seat as defined in 1.6.

Furthermore, the clearance zone shall not be outside the protection of the protective structure. For this purpose, it shall be considered to be outside the protection of the structure if any part of it would come in contact with flat ground if the tractor overturned towards the direction from which the test load is applied. For estimating this, the front and rear tyres and track width setting shall be the smallest standard fitting specified by the manufacturer.

#### 3.2.2.3 Elastic deflection (under side impact)

The elastic deflection shall be measured  $(810 + av)$  mm above the seat index point, in the vertical plane in which the load is applied. For this measurement, any apparatus similar to that illustrated in Figure 7.4 may be used.

#### 3.2.2.4 Permanent deflection

After the final crushing test, the permanent deflection of the protective structure shall be recorded. For this purpose, before the start of the test, the position of the main roll-over protective structure members in relation to the seat index point shall be used.

### 3.3 ***Extension to other tractor models***

See the provisions stated in the main Code.

### 3.4 ***Labelling***

See the requirements stated in the main Code.

### 3.5 ***Cold weather performance of protective structures***

See the requirements stated in the main Code.

### 3.6 ***Seatbelt anchorage performance***

See the provisions stated in the main Code.

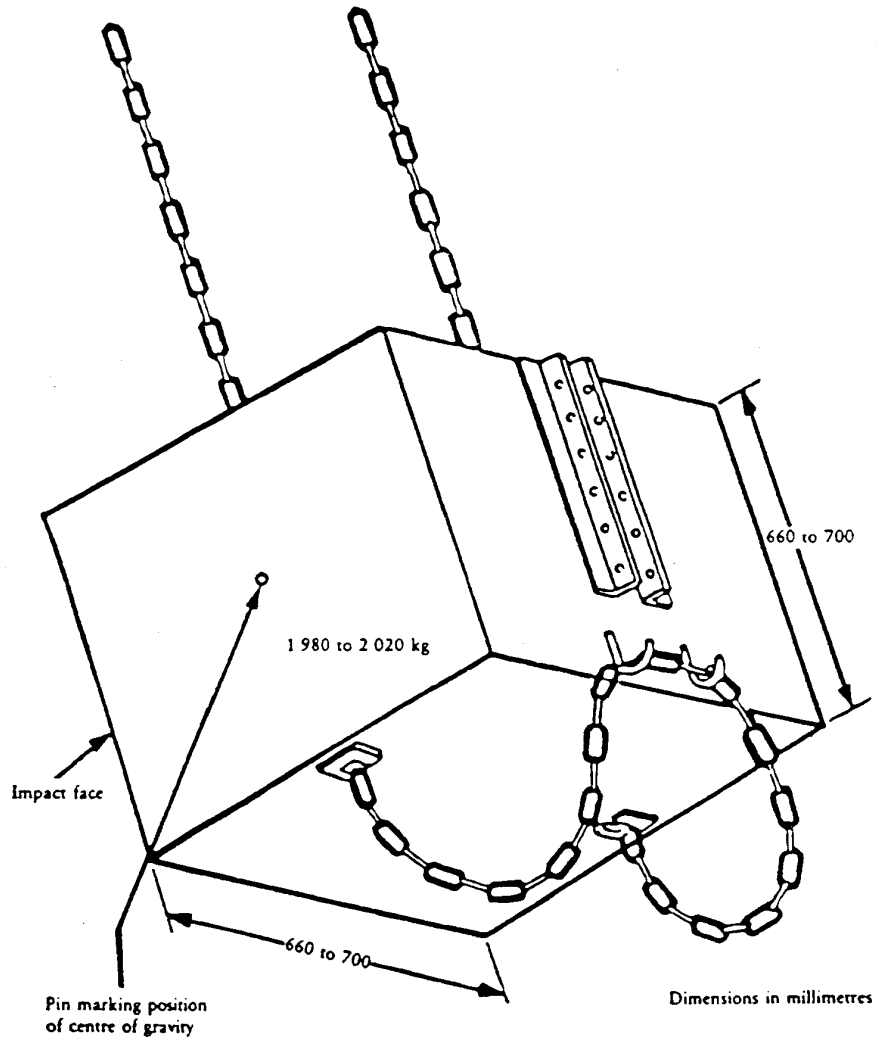

Figure 7.18

**Pendulum block and its suspending chains or wire ropes**

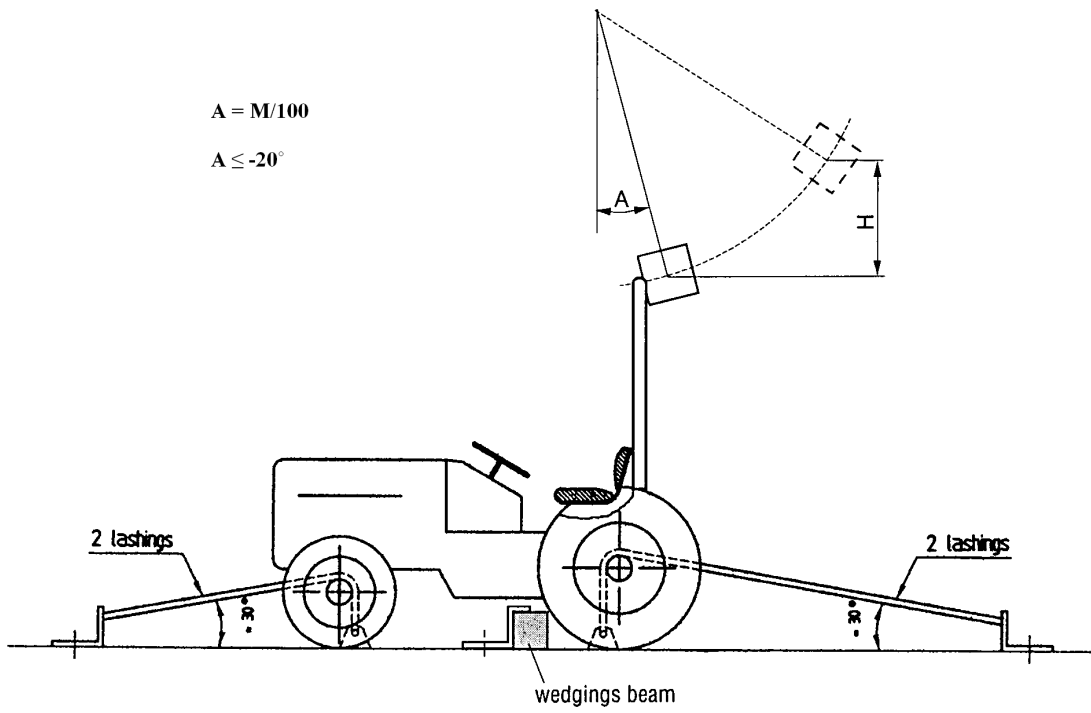

Figure 7.19

**Example of tractor lashing (rear impact)**

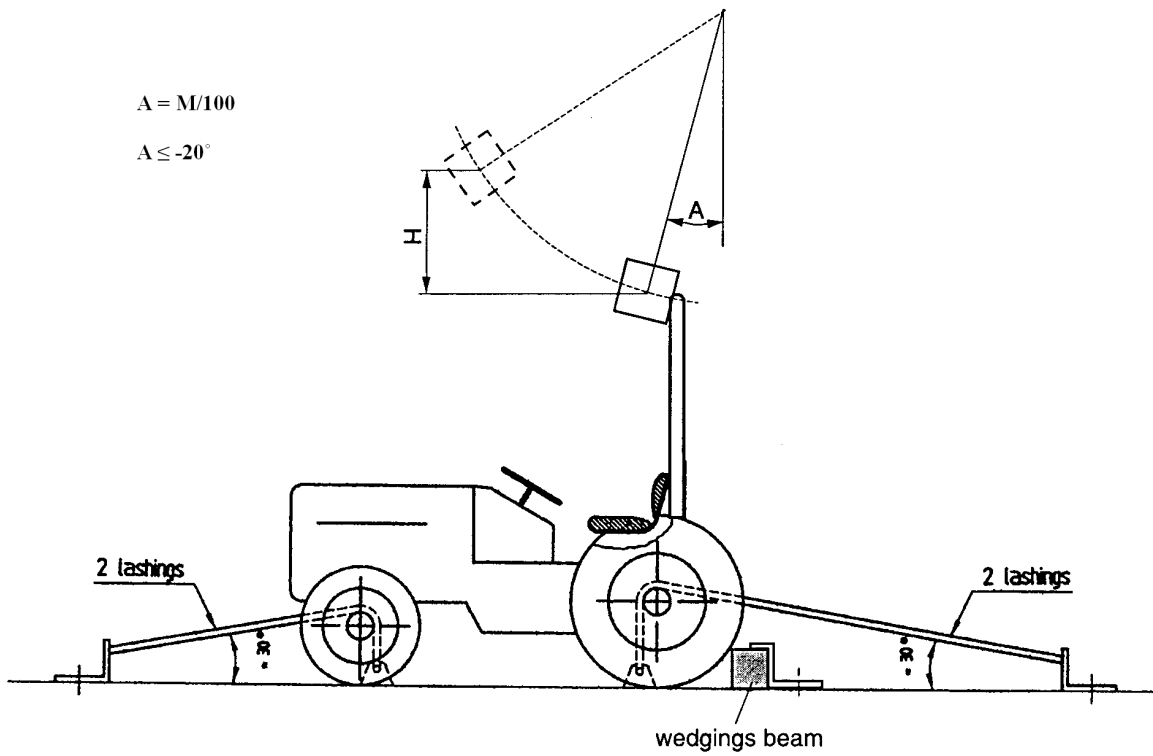

Figure 7.20

**Example of tractor lashing (front impact)**

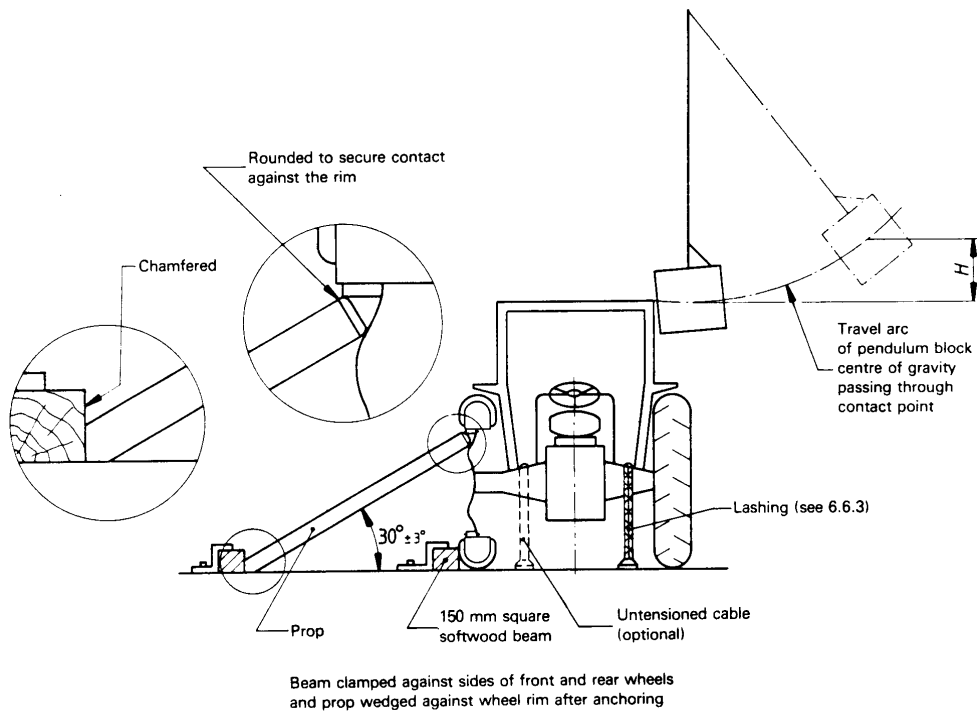

Figure 7.21

**Example of tractor lashing (side impact)**

---

# NEW AMENDMENTS IN THE 2024 EDITION OF THE OECD TRACTOR CODES

---

## Background

The 2024 edition of the Tractor Codes, released on 1 February 2024, incorporates several amendments as approved by the 2023 Annual Meeting.

Amendments:

### **General texts**

Increase of the Basic fee to 4,000 EUR

#### **Code 2**

No change

#### **Code 3**

No change

#### **Code 4**

No change

#### **Code 5**

No change

#### **Code 6**

No change

#### **Code 7**

No change

#### **Code 8**

No Change

#### **Code 9**

No change

#### **Code 10**

No change