

**CODE 6**

**OECD STANDARD CODE FOR THE OFFICIAL TESTING OF  
FRONT MOUNTED ROLL-OVER PROTECTIVE STRUCTURES  
ON NARROW-TRACK AGRICULTURAL  
AND FORESTRY TRACTORS**

## TABLE OF CONTENTS

1. DEFINITIONS .....	4
1.1 Agricultural and forestry tractors .....	4
1.2 Rolling Over Protective Structure (ROPS).....	4
1.3 Track.....	4
1.4 Wheelbase.....	5
1.5 Determination of seat index point; seat location and adjustment for test.....	5
1.6 Clearance zone.....	5
1.7 Mass.....	7
1.8 Permissible measurement tolerances .....	7
1.9 Symbols .....	8
2. FIELD OF APPLICATION.....	8
3. RULES AND DIRECTIONS .....	9
3.1 Prior conditions for the strength tests .....	9
3.2 Conditions for testing the strength of protective structures and of their attachment to tractors	13
3.3 Static test procedure.....	17
3.4 Extension to other tractor models.....	21
3.5 Labelling.....	23
3.6 Cold weather performance of protective structures.....	23
3.7 Seatbelt anchorage performance (optional).....	25
3.8 Foldable ROPS performance (optional) .....	27
SPECIMEN TEST REPORT .....	72
1. SPECIFICATIONS OF TEST TRACTOR .....	72
2. SPECIFICATIONS OF PROTECTIVE STRUCTURE.....	73
3. TEST RESULTS .....	76
SPECIMEN TECHNICAL EXTENSION REPORT .....	82
1. SPECIFICATIONS OF TEST TRACTOR .....	82
2. SPECIFICATIONS OF PROTECTIVE STRUCTURE.....	84
3. TEST RESULTS (in case of validation test).....	86
SPECIMEN ADMINISTRATIVE EXTENSION REPORT.....	92
ANNEX I CLEARANCE ZONE REFERRED TO THE SEAT REFERENCE POINT .....	93
INTRODUCTION .....	94
1. DEFINITIONS .....	94
1.5 Determination of seat reference point; Seat location and adjustment for test .....	94
1.6 Clearance zone.....	95
ANNEX II DYNAMIC TEST METHOD.....	101
INTRODUCTION .....	102

3.	RULES AND DIRECTIONS.....	102
3.1	Prior conditions for strength tests.....	102
3.2	Conditions for testing the strength of protective structures and of their attachment to tractors 102	
3.3	Dynamic test procedure.....	105
3.4	Extension to other tractor models.....	110
3.5	Labelling.....	110
3.6	Cold weather performance of protective structures.....	110
3.7	Seatbelt anchorage performance (optional).....	110

## CODE 6

### OECD STANDARD CODE FOR THE OFFICIAL TESTING OF FRONT MOUNTED ROLL-OVER PROTECTIVE STRUCTURES ON NARROW-TRACK AGRICULTURAL AND FORESTRY TRACTORS

#### 1. DEFINITIONS

##### 1.1 *Agricultural and forestry tractors*

Self-propelled wheeled vehicles, having at least two axles, or with tracks, designed to carry out the following operations, primarily for agricultural and forestry purposes:

- to pull trailers;
- to carry, pull or propel agricultural and forestry tools or machinery and, where necessary, supply power to operate them with the tractor in motion or stationary.

##### 1.2 *Rolling Over Protective Structure (ROPS)*

Roll-over protective structure (safety cab or frame), hereinafter called “protective structure”, means the structure on a tractor the essential purpose of which is to avoid or limit risks to the driver resulting from roll-over of the tractor during normal use.

The roll-over protective structure is characterized by the provision of space for a clearance zone large enough to protect the driver when seated either inside the envelope of the structure or within a space bounded by a series of straight lines from the outer edges of the structure to any part of the tractor that might come into contact with flat ground and that is capable of supporting the tractor in that position if the tractor overturns.

##### 1.3 *Track*

###### 1.3.1 Preliminary definition: median plane of the wheel or track

The median plane of the wheel or track is equidistant from the two planes containing the periphery of the rims or tracks at their outer edges.

###### 1.3.2 Definition of track

The vertical plane through the wheel axis intersects its median plane along a straight line which meets the supporting surface at one point. If **A** and **B** are the two points thus defined for the wheels on the same axle of the tractor, then the track width is the distance between points **A** and **B**. The track may be thus defined for both front and rear wheels. Where there are twin wheels, the track is the distance between two planes each being the median plane of the pairs of wheels.

For tracklaying tractors, the track is the distance between the median planes of the tracks.

### 1.3.3 Additional definition: median plane of the tractor

Take the extreme positions of points **A** and **B** for the tractor rear axle, which gives the maximum possible value for the track. The vertical plane at right angles to the line **AB** at its centre point is the median plane of the tractor.

## 1.4 *Wheelbase*

The distance between the vertical planes passing through the two lines **AB** as defined above, one for the front wheels and one for the rear-wheels. For tractors fitted with tracks: the distance between the vertical planes perpendicular to the median longitudinal plane of the tractor passing through the axles of the driving wheels.

## 1.5 *Determination of seat index point; seat location and adjustment for test*

### 1.5.1 Seat index point (SIP)<sup>1</sup>

The seat index point shall be determined in accordance with ISO 5353:1995

### 1.5.2 Seat location and adjustment for test

1.5.2.1 where the seat position is adjustable, the seat must be adjusted to its rear uppermost position;

1.5.2.2 where the inclination of the backrest is adjustable, it must be adjusted to the mid position;

1.5.2.3 where the seat is equipped with suspension, the latter must be blocked at mid-travel, unless this is contrary to the instructions clearly laid down by the seat manufacturer;

1.5.2.4 where the position of the seat is adjustable only lengthwise and vertically, the longitudinal axis passing through the seat index point shall be parallel with the vertical longitudinal plane of the tractor passing through the centre of the steering wheel and not more than 100 mm from that plane.

## 1.6 *Clearance zone*

### 1.6.1 Reference vertical plane and line

The clearance zone (Figure 6.1) is defined on the basis of a vertical reference plane and a reference line:

1.6.1.1 The reference plane is a vertical plane, generally longitudinal to the tractor and passing through the seat index point and the centre of the steering wheel. Normally the reference plane coincides with the longitudinal median plane of the tractor. This reference plane shall be assumed to move horizontally with the seat and steering wheel during loading but to remain perpendicular to the tractor or the floor of the roll-over protective structure.

1.6.1.2 The reference line is the line contained in the reference plane that passes through a point located  $140 + a_h$  rearward and  $90 - a_v$  below the seat index point and the first point on the steering wheel rim that it intersects when brought to the horizontal.

---

<sup>1</sup> For extension tests to test reports that originally used seat reference point (SRP), the required measurements shall be made with reference to SRP instead of SIP and the use of SRP shall be clearly indicated (see Annex I).

## 1.6.2 Determination of the clearance zone for tractors with a non-reversible seat

The clearance zone for tractors with a non-reversible seat is defined in 1.6.2.1 to 1.6.2.11 below and is bounded by the following planes, the tractor being on a horizontal surface, the seat adjusted and located as specified in sections 1.5.2.1 to 1.5.2.4<sup>2</sup>, and the steering wheel, where adjustable, adjusted to the mid position for seated driving:

1.6.2.1 two vertical planes 250 mm on either side of the reference plane, these vertical planes extending 300 mm upwards from the plane defined in 1.6.2.8 below and longitudinally at least 550 mm in front of the vertical plane perpendicular to the reference plane passing  $(210 - a_h)$  mm in front of the seat index point;

1.6.2.2 two vertical planes 200 mm on either side of the reference plane, these vertical planes extending 300 mm upwards from the plane defined in 1.6.2.8 below and longitudinally from the surface defined in 1.6.2.11 below to the vertical plane perpendicular to the reference plane passing  $(210 - a_h)$  mm in front of the seat index point;

1.6.2.3 an inclined plane perpendicular to the reference plane, parallel with and 400 mm above the reference line, extending backwards to the point where it intersects the vertical plane which is perpendicular to the reference plane and which passes through a point  $(140 + a_h)$  mm rearward of the seat index point;

1.6.2.4 an inclined plane, perpendicular to the reference plane which meets the plane defined in 1.6.2.3 above at its rearmost edge and rests on the top of the seat back rest;

1.6.2.5 a vertical plane perpendicular to the reference plane, passing at least 40 mm forward of the steering wheel and at least  $760 - a_h$  forward of the seat index point;

1.6.2.6 a cylindrical surface with its axis perpendicular to the reference plane, having a radius of 150 mm and tangential to the planes defined in 1.6.2.3 and 1.6.2.5;

1.6.2.7 two parallel inclined planes passing through the upper edges of the planes defined in 1.6.2.1 above with the inclined plane on the side where the impact is applied no closer than 100 mm to the reference plane above the zone of clearance;

1.6.2.8 a horizontal plane passing through a point  $90 - a_v$  below the seat index point;

1.6.2.9 two portions of the vertical plane perpendicular to the reference plane passing  $210 - a_h$  forward of the seat index point, both these part planes joining respectively the rearmost limits of the planes defined in 1.6.2.1 above to the foremost limits of the planes defined in 1.6.2.2 above;

1.6.2.10 two portions of the horizontal plane passing 300 mm above plane defined in 1.6.2.8 above, both these part planes joining respectively the uppermost limits of the vertical planes defined in 1.6.2.2 above to the lowermost limits of the oblique planes defined in 1.6.2.7 above;

1.6.2.11 a surface, curved if necessary, whose generating line is perpendicular to the reference plane and rests on the back of the seat backrest.

---

<sup>2</sup> Users are reminded that the seat index point is determined according to ISO 5353 and is a fixed point with respect to the tractor that does not move as the seat is adjusted away from the mid-position.

1.6.3 Determination of the clearance zone for tractors with a reversible driver’s position

For tractors with a reversible driver’s position (reversible seat and steering wheel), the clearance zone is the envelope of the two clearance zones defined by the two different positions of the steering wheel and the seat. For each position of steering wheel and the seat the clearance zone shall respectively be defined on the basis of above sections 1.6.1 and 1.6.2 of present Code for driver’s position in normal position and on the basis of sections 1.6.1 and 1.6.2 of Code 7 for driver’s position in reverse position (see Figure 6.2).

1.6.4 Optional seats

1.6.4.1 In case of tractors that could be fitted with optional seats, the envelope comprising the seat index points of all options offered shall be used during the tests. The protective structure shall not enter the larger clearance zone which takes account of these different seat index points.

1.6.4.2 In the case where a new seat option is offered after the test has been performed, a determination shall be made to see whether the clearance zone around the new SIP falls within the envelope previously established. If it does not, a new test must be performed.

1.6.4.3 Optional seat does not include a seat for a person in addition to the driver and from where the tractor cannot be controlled. The SIP shall not be determined because the definition of the clearance zone is in relation to the driver seat.

**1.7 Mass**

1.7.1 Unballasted / Unladen Mass

The mass of the tractor excluding optional accessories but including coolant, oils, fuel, tools plus the protective structure. Not included are optional front or rear weights, tyre ballast, mounted implements, mounted equipment or any specialised components;

1.7.2 Maximum Permissible Mass

The maximum mass of the tractor stated by the manufacturer to be technically permissible and declared on the vehicle’s identification plate and/or in the Operator’s Handbook;

1.7.3 Reference Mass

The mass, selected by the manufacturer, used in formulae to calculate the height of fall of the pendulum block, the energy inputs and crushing forces to be used in the tests. Must not be less than the unballasted mass and must be sufficient to ensure the Mass Ratio does not exceed 1.75 (see sections 1.7.4 and 2.1.3);

1.7.4 Mass Ratio

The ratio of  $\left( \frac{\text{Max. Permissible Mass}}{\text{Reference Mass}} \right)$  ..... This must not be greater than 1.75

**1.8 Permissible measurement tolerances**

Linear dimensions:	± 3 mm
except for: -- tyre deflection:	± 1 mm
-- structure deflection during horizontal loadings:	± 1 mm
-- height of fall of the pendulum block:	± 1 mm

Masses:	± 1 %
Forces: ± 2 %	
Angles:	± 2 °

## 1.9 Symbols

$a_h$	(mm)	Horizontal distance between the seat adjusted according to the point 1.5.1 and the seat adjusted according to the point 1.5.2
$a_v$	(mm)	Vertical distance between the seat adjusted according to the point 1.5.1 and the seat adjusted according to the point 1.5.2
<b>B</b>	(mm)	Minimum overall width of the tractor;
<b>B<sub>b</sub></b>	(mm)	Maximum outer width of the protective structure;
<b>D</b>	(mm)	Deflection of the structure at the point of impact (dynamic tests) or at the point of, and in line with, the load application (static tests);
<b>D'</b>	(mm)	Deflection of the structure for the calculated energy required;
<b>E<sub>a</sub></b>	(J)	Strain energy absorbed at point when load is removed. Area contained within <b>F-D</b> curve;
<b>E<sub>i</sub></b>	(J)	Strain energy absorbed. Area under <b>F-D</b> curve;
<b>E'<sub>i</sub></b>	(J)	Strain energy absorbed after additional loading following a crack or tear;
<b>E''<sub>i</sub></b>	(J)	Strain energy absorbed in overload test in the event of the load having been removed before starting this overload test. Area under <b>F-D</b> curve;
<b>E<sub>il</sub></b>	(J)	Energy input to be absorbed during longitudinal loading;
<b>E<sub>is</sub></b>	(J)	Energy input to be absorbed during side loading;
<b>F</b>	(N)	Static load force;
<b>F'</b>	(N)	Loading force for calculated energy required, corresponding to <b>E'<sub>i</sub></b> ;
<b>F-D</b>		Force/deflection diagram;
<b>F<sub>i</sub></b>	(N)	Force applied to rear hard fixture;
<b>F<sub>max</sub></b>	(N)	Maximum static load force occurring during loading, with the exception of the overload;
<b>F<sub>v</sub></b>	(N)	Vertical crushing force;
<b>H</b>	(mm)	Falling height of the pendulum block (dynamic tests);
<b>H'</b>	(mm)	Falling height of the pendulum block for additional test (dynamic tests);
<b>I</b>	(kg.m <sup>2</sup> )	Tractor reference moment of inertia about the centre line of the rear wheels, whatever the mass of these rear wheels may be;
<b>L</b>	(mm)	Tractor reference wheelbase;
<b>M</b>	(kg)	Tractor reference mass during strength tests.

## 2. FIELD OF APPLICATION

2.1 This OECD Standard Code is applicable to tractors having at least two axles for pneumatic tyre wheels or having tracks instead of wheels and shall apply to tractors having the following characteristics:

2.1.1 ground clearance of not more than 600 mm beneath the lowest points of the front and rear axles, allowing for the differential;

2.1.2 fixed or adjustable minimum track width with one of the axles less than 1 150 mm fitted with tyres or tracks of a larger size. It is assumed that the axle mounted with the wider tyres or tracks is set at a track width of not more than 1 150 mm. It must be possible to set the track width of the other axle in such a way that the outer edges of the narrower tyres or tracks do not go beyond the outer edges of the



tyres or tracks of the other axle. Where the two axles are fitted with rims and tyres or tracks of the same size, the fixed or adjustable track width of the two axles must be less than 1 150 mm;

2.1.3 mass greater than 400 kg but less than 3 500 kg, corresponding to the unladen mass of the tractor, including the roll-over protective structure and tyres or tracks of the largest size recommended by the manufacturer. The maximum permissible mass shall not exceed 5 250 kg and the Mass Ratio (*Maximum Permissible Mass / Reference Mass*) must not be greater than 1.75;

2.1.4 and being fitted with roll-over protective structures of the dual-pillar type mounted only in front of the Seat Index Point and characterised by a reduced clearance zone attributable to the tractor silhouette, thus rendering it inadvisable, under any circumstances, to impede access to the driving position but worthwhile retaining these structures (fold-down or not) in view of their undoubted ease of use.

2.2 It is recognised that there may be designs of tractors, for example, special forestry machines, such as forwarders and skidders, for which this Standard Code is not applicable.

### 3. RULES AND DIRECTIONS

#### 3.1 *Prior conditions for the strength tests*

##### 3.1.1 Completion of two preliminary tests

The protective structure may only be subjected to the strength tests if both the Lateral Stability Test and the Non-Continuous Rolling Test have been satisfactorily completed (see flow diagram as Figure 6.3).

##### 3.1.2 Preparation for the preliminary tests

3.1.2.1 The tractor must be equipped with the protective structure in its safety position.

3.1.2.2 The tractor must be fitted with tyres having the greatest diameter indicated by the manufacturer and the smallest cross-section for tyres of that diameter. The tyres must not be liquid-ballasted and must be inflated to the pressure recommended for field work.

3.1.2.3 The rear wheels must be set to the narrowest track width; the front wheels must be set as closely as possible to the same track width. If it is possible to have two front track settings which differ equally from the narrowest rear track setting, the wider of these two front track settings must be selected. In case of tractor fitted with tracks, the manufacturer shall define the tracks setting.

3.1.2.4 All the tractor's tanks must be filled or the liquids must be replaced by an equivalent mass in the corresponding position.

3.1.2.5 All attachments used in the series production shall be fixed to the tractor in the normal position.

##### 3.1.3 Lateral stability test

3.1.3.1 The tractor, prepared as specified above, is placed on a horizontal plane so that the tractor front-axle pivot point or, in the case of an articulated tractor, the horizontal pivot point between the two axles can move freely.

3.1.3.2 Using a jack or a hoist, tilt the part of the tractor which is rigidly connected to the axle that bears more than 50 per cent of the tractor's weight, while constantly measuring the angle of inclination. This angle must be at least 38° at the moment when the tractor is resting in a state of unstable equilibrium

on the wheels or tracks touching the ground. Perform the test once with the steering wheel turned to full right lock and once with the steering wheel turned to full left lock.

### 3.1.4 Non-continuous rolling test

#### 3.1.4.1 General remarks

This test is intended to check whether a structure fitted to the tractor for the protection of the driver can satisfactorily prevent continuous roll-over of the tractor in the event of its overturning laterally on a slope with a gradient of 1 in 1.5 (Figure 6.4).

Evidence of non-continuous rolling can be provided in accordance with one of the two methods described in 3.1.4.2 and 3.1.4.3.

#### 3.1.4.2 Demonstration of non-continuous rolling behaviour by means of the overturning test

3.1.4.2.1 The overturning test must be carried out on a test slope at least four metres long (see Figure 6.4). The surface must be covered with an 18-cm layer of a material that, as measured in accordance with Standards ASAE S313.3 FEB1999 and ASAE EP542 FEB1999 relating to soil cone penetrometer, has a cone penetration index of:

$$A = 235 \pm 20$$

or

$$B = 335 \pm 20$$

3.1.4.2.2 The tractor (prepared as described in paragraph 3.1.2) is tilted laterally with zero initial speed. For this purpose, it is placed at the start of the test slope in such a way that the wheels on the downhill side rest on the slope and the tractor's median plane is parallel with the contour lines. After striking the surface of the test slope, the tractor may lift itself from the surface by pivoting about the upper corner of the protective structure, but it must not roll over. It must fall back on the side which it first struck.

#### 3.1.4.3 Demonstration of non-continuous rolling behaviour by calculation

3.1.4.3.1 For the purpose of verifying non-continuous rolling behaviour by calculation, the following characteristic tractor data must be ascertained (see Figure 6.5):

<b>B<sub>0</sub></b>	(m)	Rear tyre or track width;
<b>B<sub>6</sub></b>	(m)	Width of protective structure between the right and left points of impact;
<b>B<sub>7</sub></b>	(m)	Width of engine bonnet;
<b>D<sub>0</sub></b>	(rad)	Front-axle swing angle from zero position to end of travel;
<b>D<sub>2</sub></b>	(m)	Height of front tyres or tracks under full axle load;
<b>D<sub>3</sub></b>	(m)	Height of rear tyres or tracks under full axle load;
<b>H<sub>0</sub></b>	(m)	Height of the front-axle pivot point;
<b>H<sub>1</sub></b>	(m)	Height of centre of gravity;
<b>H<sub>6</sub></b>	(m)	Height at the point of impact;
<b>H<sub>7</sub></b>	(m)	Height of engine bonnet;
<b>L<sub>2</sub></b>	(m)	Horizontal distance between the centre of gravity and front axle;
<b>L<sub>3</sub></b>	(m)	Horizontal distance between the centre of gravity and rear axle;

<b>L<sub>6</sub></b>	(m)	Horizontal distance between the centre of gravity and the leading point of intersection of the protective structure (to be preceded by a minus sign if this point lies in front of the plane of the centre of gravity);
<b>L<sub>7</sub></b>	(m)	Horizontal distance between the centre of gravity and the front corner of the engine bonnet;
<b>M<sub>c</sub></b>	(kg)	Tractor mass used for calculation;
<b>Q</b>	(kgm <sup>2</sup> )	Moment of inertia about the longitudinal axis through the centre of gravity;
<b>S</b>	(m)	Rear track width.

The sum of the rear track width (**S**) and tyre or track (**B<sub>0</sub>**) widths must be greater than the width **B<sub>6</sub>** of the protective structure.

3.1.4.3.2 For the purposes of calculation, the following simplifying assumptions can be made:

3.1.4.3.2.1 the stationary tractor overturns on a slope with a 1/1.5 gradient with a balanced front axle, as soon as the centre of gravity is vertically above the axis of rotation;

3.1.4.3.2.2 the axis of rotation is parallel to the tractor's longitudinal axis and passes through the centre of the contact surfaces of the downhill front and rear wheel or track;

3.1.4.3.2.3 the tractor does not slide downhill;

3.1.4.3.2.4 impact on the slope is partly elastic, with a coefficient of elasticity of:

$$U = 0.2$$

3.1.4.3.2.5 the depth of penetration into the slope and the deformation of the protective structure together amount to:

$$T = 0.2 m$$

3.1.4.3.2.6 no other components of the tractor penetrate into the slope.

3.1.4.3.3 The computer programme (BASIC) for determining the continuous or interrupted roll-over behaviour of a laterally overturning narrow-track tractor with a front-mounted roll-over protective structure is part of the present Code, with examples 6.1 to 6.11.

### 3.1.5 Measurement methods

3.1.5.1 Horizontal distances between the centre of gravity and rear (**L<sub>3</sub>**) or front (**L<sub>2</sub>**) axles

The distance between the rear and front axles on both sides of the tractor shall be measured in order to verify there is no steering angle.

The distances between the centre of gravity and the rear axle (**L<sub>3</sub>**) or the front axle (**L<sub>2</sub>**) shall be calculated from the mass distribution of the tractor between the rear and the front wheels or tracks.

3.1.5.2 Heights of rear (**D<sub>3</sub>**) and front (**D<sub>2</sub>**) tyres or tracks

The distance from the highest point of the tyre or tracks to the ground plane shall be measured (Figure 6.5), and the same method shall be used for the front and rear tyres or tracks.

3.1.5.3 Horizontal distance between the centre of gravity and the leading point of intersection of the protective structure ( $L_6$ ).

The distance between the centre of gravity and the leading point of intersection of the protective structure shall be measured (Figures 6.6.a, 6.6.b and 6.6.c). If the protective structure is in front of the plane of the centre of gravity, the recorded measure will be preceded by a minus sign ( $-L_6$ ).

3.1.5.4 Width of the protective structure ( $B_6$ )

The distance between the right and left points of impact of the two vertical posts of the structure shall be measured.

The point of impact is defined by the plane tangent to the protective structure passing through the line made by the top outer points of the front and rear tyres or tracks (Figure 6.7).

3.1.5.5 Height of the protective structure ( $H_6$ )

The vertical distance from the point of impact of the structure to the ground plane shall be measured.

3.1.5.6 Height of the engine bonnet ( $H_7$ )

The vertical distance from the point of impact of the engine bonnet to the ground plane shall be measured.

The point of impact is defined by the plane tangent to the engine bonnet and the protective structure passing through the top outer points of the front tyre or track (Figure 6.7). The measurement shall be made on both sides of the engine bonnet.

3.1.5.7 Width of the engine bonnet ( $B_7$ )

The distance between the two points of impact of the engine bonnet as defined previously shall be measured.

3.1.5.8 Horizontal distance between the centre of gravity and the front corner of the engine bonnet ( $L_7$ )

The distance from the point of impact of the engine bonnet, as defined previously, to the centre of gravity shall be measured.

3.1.5.9 Height of the front-axle pivot point ( $H_0$ )

The vertical distance between the centre of the front-axle pivot point to the centre of axle of the front tyres or tracks ( $H_{01}$ ) shall be included in the manufacturer's technical report and shall be checked.

The vertical distance from the centre of the front tyres or tracks axle to the ground plane ( $H_{02}$ ) shall be measured (Figure 6.8).

The height of the front-axle pivot ( $H_0$ ) is the sum of both previous values.

3.1.5.10 Rear track width ( $S$ )

The minimum rear track width fitted with tyres or tracks of the largest size, as specified by the manufacturer, shall be measured (Figure 6.9).

#### 3.1.5.11 Rear tyre or track width ( $B_0$ )

The distance between the outer and the inner vertical planes of a rear tyre or track in its upper part shall be measured (Figure 6.9).

#### 3.1.5.12 Front axle swinging angle ( $D_0$ )

The largest angle defined by the swinging of the front axle from the horizontal position to the maximum deflection shall be measured on both sides of the axle, taking into account any end-stroke shock absorber. The maximum angle measured shall be used.

#### 3.1.5.13 Tractor Mass

The tractor mass shall be determined according to the conditions specified in section 1.7.1.

### 3.2 *Conditions for testing the strength of protective structures and of their attachment to tractors*

#### 3.2.1 General requirements

##### 3.2.1.1 Test purposes

Tests made using special rigs are intended to simulate such loads as are imposed on a protective structure, when the tractor overturns. These tests enable observations to be made on the strength of the protective structure and any brackets attaching it to the tractor and any parts of the tractor which transmit the test load.

##### 3.2.1.2 Test methods

Tests may be performed in accordance with the static procedure or the dynamic procedure (see Annex II). The two methods are deemed equivalent.

##### 3.2.1.3 General rules governing preparation for tests

3.2.1.3.1 The protective structure must conform to the series production specifications. It shall be attached in accordance with the manufacturer's recommended method to one of the tractors for which it is designed.

**Note:** A complete tractor is not required for the static strength test; however, the protective structure and parts of the tractor to which it is attached represent an operating installation, hereinafter referred to as « the assembly ».

3.2.1.3.2 For both the static test and the dynamic test the tractor as assembled (or the assembly) must be fitted with all series production components which may affect the strength of the protective structure or which may be necessary for the strength test.

Components which may create a hazard in the clearance zone must also be fitted on the tractor (or the assembly) so that they may be examined to see whether the requirements of the Acceptance Conditions in 3.2.3 have been fulfilled.

All components of the tractor or the protective structure including weather protective must be supplied or described on drawings.

3.2.1.3.3 For the strength tests, all panels and detachable non-structural components must be removed so that they may not contribute to the strengthening of the protective structure.

3.2.1.3.4 The track width must be adjusted so that the protective structure will, as far as possible, not be supported by the tyres or tracks during the strength tests. If these tests are conducted in accordance with the static procedure, the wheels or tracks may be removed.

## 3.2.2 Tests

### 3.2.2.1 Sequence of tests according to the Static Procedure

The sequence of tests, without prejudice to the additional tests mentioned in sections 3.3.1.6, and 3.3.1.7 is as follows:

- (1) **loading at the rear of the structure**  
(see 3.3. 1.1);
- (2) **crushing at the rear of the structure**  
(see 3.3.1.4);
- (3) **loading at the front of the structure**  
(see 3.3. 1.2);
- (4) **loading at the side of the structure**  
(see 3.3.1.3);
- (5) **crushing at the front of the structure**  
(see 3.3. 1.5).

### 3.2.2.2 General requirements

3.2.2.2.1 If, during the test, any part of the tractor restraining equipment breaks or moves, the test shall be restarted.

3.2.2.2.2 No repairs or adjustments of the tractor or protective structure may be carried out during the tests.

3.2.2.2.3 The tractor gear box shall be in neutral and the brakes off during the tests.

3.2.2.2.4 If the tractor is fitted with a suspension system between the tractor body and the wheels or tracks, it shall be blocked during the tests.

3.2.2.2.5 The side chosen for application of the first load on the rear of the structure shall be that which, in the opinion of the testing authorities, will result in the application of the series of loads under the most unfavourable conditions for the structure. The lateral load and the rear load shall be applied on both sides of the longitudinal median plane of the protective structure. The front load shall be applied on the same side of the longitudinal median plane of the protective structure as the lateral load.

### 3.2.3 Acceptance conditions

3.2.3.1 A protective structure is regarded as having satisfied the strength requirements if it fulfils the following conditions:

3.2.3.1.1 After each part-test it must be free from cracks or tears within the meaning of section 3.3.2.1 or

3.2.3.1.2 If, during one of the crushing tests, significant cracks or tears appear, an additional test, in accordance with section 3.3.1.7, must be applied immediately after the crushing which caused cracks or tears to appear;

3.2.3.1.3 during the tests other than the overload test, no part of the protective structure must enter the clearance zone as defined in 1.6;

3.2.3.1.4 during the tests other than the overload test, all parts of the clearance zone shall be secured by the structure, in accordance with 3.3.2.2;

3.2.3.1.5 during the tests the protective structure must not impose any constraints on the seat structure;

3.2.3.1.6 the elastic deflection, measured in accordance with 3.3.2.4 shall be less than 250 mm.

3.2.3.2 There shall be no accessories presenting a hazard for the driver. There shall be no projecting part or accessory which is liable to injure the driver should the tractor overturn, or any accessory or part which is liable to trap him – for example by the leg or the foot – as a result of the deflections of the structure.

### 3.2.4 Test report

3.2.4.1 The report shall include:

3.2.4.1.1 a general description of the protective structure's shape and construction (normally at least to the scale of 1/20 for general drawings and 1/2.5 for drawings of attachments). The main dimensions must figure on the drawings, including external dimensions of tractor with protective structure fitted and main interior dimensions;

3.2.4.1.2 a general description of materials and fastening;

3.2.4.1.3 details of provisions for normal entry and exit and for escape where appropriate;

3.2.4.1.4 details of heating and ventilation system, where appropriate;

3.2.4.1.5 a brief description of any interior padding, where appropriate.

3.2.4.2 The test report must identify clearly the tractor (make, type, model, trade name, etc.) used for testing and other tractors for which the protective structure is intended.

### 3.2.5 Test apparatus and equipment

3.2.5.1 Static testing rig

3.2.5.1.1 The static testing rig must be designed in such a way as to permit thrusts or loads to be applied to the protective structure.

3.2.5.1.2 Provision must be made so that the load can be uniformly distributed normal to the direction of loading and along a flange having a length of one of the exact multiples of 50 between 250 and 700 mm. The stiff beam shall have a vertical face dimension of 150 mm. The edges of the beam in contact with the protective structure shall be curved with a maximum radius of 50 mm.

3.2.5.1.3 The pad shall be capable of being adjusted to any angle in relation to the load direction, in order to be able to follow the angular variations of the structure's load-bearing surface as the structure deflects.

3.2.5.1.4 Direction of the force (deviation from horizontal and vertical):

- at start of test, under zero load:  $\pm 2^\circ$ ;
- during test, under load:  $10^\circ$  above and  $20^\circ$  below the horizontal. These variations must be kept to a minimum.

3.2.5.1.5 The deflection rate shall be sufficiently slow, less than 5 mm/s so that the load may at all moments be considered as static.

3.2.5.2 Apparatus for measuring the energy absorbed by the structure

3.2.5.2.1 The force versus deflection curve shall be plotted in order to determine the energy absorbed by the structure. There is no need to measure the force and deflection at the point where the load is applied to the structure; however, force and deflection shall be measured simultaneously and co-linearly.

3.2.5.2.2 The point of origin of deflection measurements shall be selected so as to take account only of the energy absorbed by the structure and/or by the deflection of certain parts of the tractor. The energy absorbed by the deflection and/or the slipping of the anchoring must be ignored.

3.2.5.3 Means of anchoring the tractor to the ground

3.2.5.3.1 Anchoring rails with the requisite track width and covering the necessary area for anchoring the tractor in all the cases illustrated must be rigidly attached to a non-yielding base near the testing rig.

3.2.5.3.2 The tractor must be anchored to the rails by any suitable means (plates, wedges, wire ropes, jacks, etc.) so that it cannot move during the tests. This requirement shall be checked during the test, by means of the usual devices for measuring length.

If the tractor moves, the entire test shall be repeated, unless the system for measuring the deflections taken into account for plotting the force versus deflection curve is connected to the tractor.

3.2.5.4 Crushing rig

A rig as shown in Figure 6.10 shall be capable of exerting a downward force on a protective structure through a rigid beam approximately 250 mm wide, connected to the load-applying mechanism by means of universal joints. Suitable axle stands must be provided so that the tractor tyres or tracks do not bear the crushing force.



### 3.2.5.5 Other measuring apparatus

The following measuring devices are also needed:

3.2.5.5.1 A device for measuring the elastic deflection (the difference between the maximum momentary deflection and the permanent deflection, (see Figure 6.11).

3.2.5.5.2 A device for checking that the protective structure has not entered the clearance zone and that the latter has remained within the structure's protection during the test (section 3.3.2.2).

## 3.3 *Static test procedure*

### 3.3.1 Loading and crushing tests

#### 3.3.1.1 Loading at the rear

3.3.1.1.1 The load shall be applied horizontally in a vertical plane parallel to the tractor's median plane.

The load application point shall be that part of the roll-over protective structure likely to hit the ground first in a rearward overturning accident, normally the upper edge. The vertical plane in which the load is applied shall be located at a distance of 1/6 of the width of the top of the protective structure inwards from a vertical plane, parallel to the median plane of the tractor, touching the outside extremity of the top of the protective structure.

If the structure is curved or protruding at this point, wedges enabling the load to be applied thereon shall be added, without thereby reinforcing the structure.

3.3.1.1.2 The assembly shall be lashed to the ground as described in 3.2.5.3.

3.3.1.1.3 The energy absorbed by the protective structure during the test shall be at least:

$$E_{i1} = 500 + 0.5 M$$

3.3.1.1.4 For tractors with a reversible driver's position (reversible seat and steering wheel), the same formula shall apply.

#### 3.3.1.2 Loading at the front

3.3.1.2.1 The load shall be applied horizontally, in a vertical plane parallel to the tractor's median plane and located at a distance of 1/6 of the width of the top of the protective structure inwards from a vertical plane, parallel to the median plane of the tractor, touching the outside extremity of the top of the protective structure.

The load application point shall be that part of the roll-over protective structure likely to hit the ground first if the tractor overturned sideways while travelling forward, normally the upper edge.

If the structure is curved or protruding at this point, wedges enabling the load to be applied thereon shall be added, without thereby reinforcing the structure.

3.3.1.2.2 The assembly shall be lashed to the ground as described in 3.2.5.3.

3.3.1.2.3 The energy absorbed by the protective structure during the test shall be at least:

$$E_{i l} = 500 + 0.5 M$$

3.3.1.2.4 For tractors with a reversible driver's position (reversible seat and steering wheel), the energy shall be whichever is the higher of the above or either of the following as selected:

$$E_{i l} = 2.165 \times 10^{-7} M \times L^2$$

or

$$E_{i l} = 0.574 I$$

3.3.1.3 Loading from the side

3.3.1.3.1 The side loading shall be applied horizontally, in a vertical plane perpendicular to the tractor's median plane. The load application point shall be that part of the roll-over protective structure likely to hit the ground first in a sideways overturning accident, normally the upper edge.

3.3.1.3.2 The assembly shall be lashed to the ground as described in 3.2.5.3.

3.3.1.3.3 The energy absorbed by the protective structure during the test shall be at least:

$$E_{i s} = 1.75 M(B_6+B) / 2B$$

3.3.1.3.4 For tractors with a reversible driver's position (reversible seat and steering wheel), the energy shall be whichever is higher of the above or the following:

$$E_{i s} = 1.75 M$$

## 3.3.1.4 Crushing at the rear

The beam shall be positioned over the rear uppermost structural member(s) and the resultant of crushing forces shall be located in the tractor's median plane. A force  $F_v$  shall be applied where:

$$F_v = 20 M$$

The force  $F_v$  shall be maintained for five seconds after cessation of any visually detectable movement of the protective structure.

Where the rear part of the protective structure roof will not sustain the full crushing force, the force shall be applied until the roof is deflected to coincide with the plane joining the upper part of the protective structure with that part of the rear of the tractor capable of supporting the tractor when overturned.

The force shall then be removed, and the crushing beam repositioned over that part of the protective structure which would support the tractor when completely overturned. The crushing force  $F_v$  shall then be applied again.

## 3.3.1.5 Crushing at the front

The beam shall be positioned across the front uppermost structural member(s) and the resultant of crushing forces shall be located in the tractor's median plane. A force  $F_v$  shall be applied where:

$$F_v = 20 M$$

The force  $F_v$  shall be maintained for five seconds after the cessation of any visually detectable movement of the protective structure.

Where the front part of the protective structure roof will not sustain the full crushing force, the force shall be applied until the roof is deflected to coincide with the plane joining the upper part of the protective structure with that part of the front of the tractor capable of supporting the tractor when overturned.

The force shall then be removed, and the crushing beam repositioned over that part of the protective structure which would support the tractor when completely overturned. The crushing force  $F_v$  shall then be applied again.

## 3.3.1.6 Additional overload test (Figures 6.14 to 6.16)

An overload test shall be carried out in all cases where the force decreases by more than 3 per cent during the last 5 per cent of the deflection reached when the energy required is absorbed by the structure (see Figure 6.15).

The overload test involves the gradual increase of the horizontal load by increments of 5 per cent of the initial energy requirement up to a maximum of 20 per cent of energy added (see Figure 6.16).

The overload test is satisfactory if, after each increase by 5, 10, or 15 per cent in the energy required, the force decreases by less than 3 per cent for a 5 per cent increment and remains greater than  $0.8 F_{\max}$ .

The overload test is satisfactory if, after the structure has absorbed 20 per cent of the added energy, the force exceeds  $0.8 F_{\max}$ .

Additional cracks or tears and/or entry into or lack of protection of the clearance zone due to elastic deflection are permitted during the overload test. However, after the removal of the load, the structure shall not enter the clearance zone, which shall be completely protected.

#### 3.3.1.7 Additional crushing tests

If cracks or tears which cannot be considered as negligible appear during a crushing test, a second, similar crushing, but with a force of  $1.2 F_v$  shall be applied immediately after the crushing test which caused the cracks or tears to appear.

Additional cracks or tears or entry into or lack of protection of the clearance zone, due to elastic deformation, are permitted during the additional crushing test. After removing the load, however, the protective structure shall not infringe on the clearance zone, which shall be completely protected.

### 3.3.2 Measurements to be made

#### 3.3.2.1 Fractures and cracks

After each test all structural members, joints and attachment systems shall be visually examined for fractures or cracks, any small cracks in unimportant parts being ignored.

#### 3.3.2.2 Entry into the clearance zone

During each test the protective structure shall be examined to see whether any part of it has entered the clearance zone as defined in 1.6 above.

Furthermore, the clearance zone shall not be outside the protection of the protective structure. For this purpose, it shall be considered to be outside the protection of the structure if any part of it would come in contact with flat ground if the tractor overturned towards the direction from which the test load is applied. For estimating this, the front and rear tyres or tracks and track width setting shall be the smallest standard fitting specified by the manufacturer.

#### 3.3.2.3 Rear hard fixture tests

If the tractor is fitted with a rigid section, a housing or other hard fixture placed behind the driver's seat, this fixture shall be regarded as a protective point, in the event of sideways or rear overturning. This hard fixture placed behind the driver's seat shall be capable of withstanding, without breaking or entering the clearance zone, a downward force  $F_i$ , where:

$$F_i = 15 M$$

applied perpendicularly to the top of the frame in the central plane of the tractor. The initial angle of application of force shall be 40° calculated from a parallel to the ground as shown in Figure 6.12. The minimum width of this rigid section shall be 500 mm (see Figure 6.13).

In addition, it shall be sufficiently rigid and firmly attached to the rear of the tractor.

#### 3.3.2.4 Elastic deflection under side loading

The elastic deflection shall be measured (810+a<sub>v</sub>) mm above the seat index point, in the vertical plane in which the load is applied. For this measurement, any apparatus similar to that illustrated in Figure 6.11 shall be used.

#### 3.3.2.5 Permanent deflection

After the final crushing test the permanent deflection of the protective structure shall be recorded. For this purpose, before the start of the test, the position of the main roll-over protective structure members in relation to the seat index point shall be recorded.

### 3.4 *Extension to other tractor models*

#### 3.4.1 Administrative extension

If there are changes in the make, denomination or marketing features of the tractor or protective structure tested or listed in the original test report, the testing station that has carried out the original test can issue an “administrative extension report”. This extension report shall contain a reference to the original test report.

#### 3.4.2 Technical extension

When technical modifications occur on the tractor, the protective structure or the method of attachment of the protective structure to the tractor, the testing station that has carried out the original test can issue a “technical extension report” if the tractor and protective structure satisfied preliminary tests of lateral stability and non-continuous rolling as defined in 3.1.3 and 3.1.4 and if the rear hard fixture as described in paragraph 3.3.2.3., when fitted, has been tested in accordance with the procedure described in this paragraph (except 3.4.2.2.4) in the following cases:

##### 3.4.2.1 Extension of the structural test results to other models of tractors

The impact or loading and crushing tests need not be carried out on each model of tractor, provided that the protective structure and tractor comply with the conditions referred to hereunder in 3.4.2.1.1 to 3.4.2.1.5.

3.4.2.1.1 The structure (including rear hard fixture) shall be identical to the one tested;

3.4.2.1.2 The required energy shall not exceed the energy calculated for the original test by more than 5 per cent;

3.4.2.1.3 The method of attachment and the tractor components to which the attachment is made shall be identical;

3.4.2.1.4 Any components such as mudguards and bonnet that may provide support for the protective structure shall be identical;

3.4.2.1.5 The position and critical dimensions of the seat in the protective structure and the relative position of the protective structure on the tractor shall be such that the clearance zone would have remained within the protection of the deflected structure throughout all tests (this shall be checked by using the same reference of clearance zone as in the original test report, respectively Seat Reference Point [SRP] or Seat Index Point [SIP]).

#### 3.4.2.2 Extension of the structural test results to modified models of the protective structure

This procedure has to be followed when the provisions of section 3.4.2.1 are not fulfilled, it may not be used when the method of attachment of the protective structure to the tractor does not remain of the same principle (e.g. rubber supports replaced by a suspension device):

3.4.2.2.1 Modifications having no impact on the results of the initial test (e.g. weld attachment of the mounting plate of an accessory in a non-critical location on the structure), addition of seats with different SIP location in the protective structure (subject to checking that the new clearance zone(s) remain(s) within the protection of the deflected structure throughout all tests).

3.4.2.2.2 Modifications having a possible impact on the results of the original test without calling into question the acceptability of the protective structure (e.g. modification of a structural component, modification of the method of attachment of the protective structure to the tractor). A validation test can be carried out and the test results will be drafted in the extension report.

The following limits for this type extension are fixed:

3.4.2.2.2.1 no more than 5 extension may be accepted without a validation test;

3.4.2.2.2.2 the results of the validation test will be accepted for extension if all the acceptance conditions of the Code are fulfilled and :

- if the deflection measured after each impact test does not deviate from the deflection measured after each impact test in the original test report by more than  $\pm 7\%$  (in the case of dynamic tests);
- if the force measured when the required energy level has been reached in the various horizontal load tests does not deviate from the force measured when the required energy has been reached in the original test by more than  $\pm 7\%$  and the deflection measured<sup>3</sup> when the required energy level has been reached in the various horizontal load tests does not deviate from the deflection measured when the required energy has been reached in the original test report by more than  $\pm 7\%$  (in the case of static tests).

3.4.2.2.2.3 more than one protective structure modifications may be included in a single extension report if they represent different options of the same protective structure, but only one validation test can be accepted in a single extension report. The options not tested shall be described in a specific section of the extension report.

3.4.2.2.3 Increase of the reference mass declared by the manufacturer for a protective structure already tested. If the manufacturer wants to keep the same approval number it is possible to issue an

---

<sup>3</sup> Permanent + elastic deflection measured at the point when the required energy level is obtained.

extension report after having carried out a validation test (the limits of  $\pm 7\%$  specified in 3.4.2.2.2 are not applicable in such a case).

3.4.2.2.4 Modification of the rear hard fixture or addition of a new rear hard fixture. It has to be checked that the clearance zone remains within the protection of the deflected structure throughout all test taking into account the new or modified rear hard fixture. A validation of the rear hard fixture consisting in the test described in 3.3.2.3 has to be carried out and the test results will be drafted in the extension report.

### **3.5 Labelling**

3.5.1 OECD labelling is optional. If it is utilised, it shall contain at least the following information:

3.5.1.1 OECD reference;

3.5.1.2 OECD approval number.

3.5.2 The label shall be durable and permanently attached to the protective structure so that it can be easily read and it shall be protected from environmental damage.

### **3.6 Cold weather performance of protective structures**

3.6.1 If the protective structure is claimed to have properties resistant to cold weather embrittlement, the manufacturer shall give details that shall be included in the report.

3.6.2 The following requirements and procedures are intended to provide strength and resistance to brittle fracture at reduced temperatures. It is suggested that the following minimum material requirements shall be met in judging the protective structure's suitability at reduced operating temperatures in those countries requiring this additional operating protection.

3.6.2.1 Bolts and nuts used to attach the protective structure to the tractor and used to connect structural parts of the protective structure shall exhibit suitable controlled reduced temperature toughness properties.

3.6.2.2 All welding electrodes used in the fabrication of structural members and mounts shall be compatible with the protective structure material as given in 3.6.2.3 below.

3.6.2.3 Steel materials for structural members of the protective structure shall be of controlled toughness material exhibiting minimum Charpy V-Notch impact energy requirements as shown in Table 6.1. Steel grade and quality shall be specified in accordance with ISO 630-1,2,3,4:2011-2012.

Steel with an as-rolled thickness less than 2.5 mm and with a carbon content less than 0.2 per cent is considered to meet this requirement.

Structural members of the protective structure made from materials other than steel shall have equivalent low temperature impact resistance.

3.6.2.4 When testing the Charpy V-Notch impact energy requirements, the specimen size shall be no less than the largest of the sizes stated in Table 6.1 that the material will permit.

3.6.2.5 The Charpy V-Notch tests shall be made in accordance with the procedure in ASTM A 370-1979, except for specimen sizes that shall be in accordance with the dimensions given in table 6.1.

3.6.2.6 Alternatives to this procedure are the use of killed or semi-killed steel for which an adequate specification shall be provided. Steel grade and quality shall be specified in accordance with ISO 630-1,2,3,4:2011-2012.

3.6.2.7 Specimens are to be longitudinal and taken from flat stock, tubular or structural sections before forming or welding for use in the protective structure. Specimens from tubular or structural sections are to be taken from the middle of the side of greatest dimension and shall not include welds.



Specimen size	Energy at	Energy at
	-30 °C	-20 °C
mm	J	J <sup>b)</sup>
10 x 10 <sup>a)</sup>	11	27.5
10 x 9	10	25
10 x 8	9.5	24
10 x 7,5 <sup>a)</sup>	9.5	24
10 x 7	9	22.5
10 x 6.7	8.5	21
10 x 6	8	20
10 x 5 <sup>a)</sup>	7.5	19
10 x 4	7	17.5
10 x 3.5	6	15
10 x 3	6	15
10 x 2.5 <sup>a)</sup>	5.5	14

Table 6.1  
Minimum Charpy V-notch impact energies

- <sup>a)</sup> Indicates preferred size. Specimen size shall be no less than largest preferred size that the material permits.
- <sup>b)</sup> The energy requirement at -20 °C is 2.5 times the value specified for -30 °C. Other factors affect impact energy strength, i.e. direction of rolling, yield strength, grain orientation and welding. These factors shall be considered when selecting and using steel.

### 3.7 *Seatbelt anchorage performance (optional)*

#### 3.7.1 Scope

Seat belts are one of the operator restraint systems used for securing the driver in motor vehicles.

This recommended procedure provides minimum performance and tests requirements for anchorage for agricultural and forestry tractors.

It applies to the anchorage of pelvic restraint systems.

#### 3.7.2 Explanation of terms used in the performance testing

3.7.2.1 The *seat belt assembly* is any strap or belt device fastened across the lap or pelvic girdle area designed to secure a person in a machine.

3.7.2.2 The *extension belt* is intended as any strap, belt, or similar device that aids in the transfer of seat belt loads.

3.7.2.3 The *anchorage* is intended as the point where the seat belt assembly is mechanically attached to the seat system or tractor.

3.7.2.4 The *seat mounting* is intended as all intermediary fittings (such as slides, etc.) used to secure the seat to the appropriate part of the tractor.

3.7.2.5 The *Operator Restraint System* is intended as the total system composed of seat belt assembly, seat system, anchorages and extension which transfers the seat belt load to the tractor.

3.7.2.6 *Applicable Seat Components* comprise all components of the seat whose mass could contribute to loading of the seat mounting (to the vehicle structure) during a roll-over event.

### 3.7.3 Test procedure

The procedure is applicable to a seat belt anchorage system provided for a driver or a person in addition to the driver carried by the tractor.

Only static tests for anchorages are given in this procedure.

If, for a given protective structure, a manufacturer provides more than one seat with identical components which transfer the load from the seatbelt anchorage to the seat mounting on the ROPS floor or tractor chassis, the Testing Station is authorized to test only one configuration, corresponding to the heaviest seat.

The seat shall be in position during the tests and fixed to the mounting point on the tractor using all intermediary fittings (such as suspension, slides, etc.) specified for the complete tractor. No additional non-standard fittings contributing to the strength of the construction may be used.

The worst case loading scenario for seat belt anchorage performance testing should be identified with consideration to the following points:-

- If the masses of alternative seats are comparable, those featuring seat belt anchorages which transfer loading through the seat structure (*e.g. via the suspension system and/or adjustment slides*), will be required to withstand much higher test loading. They are therefore likely to represent the worst case;
- If the applied loading will pass through the seat mountings to the vehicle chassis, the seat should be adjusted longitudinally to achieve the minimum amount of overlap of the mounting slides / rails. This will usually be when the seat is in the fully-rearward position but, if certain vehicle installations limit seat rearward travel, the fully-forward seat position may provide the worst case loading position. Observation of the amount of seat movement and mounting slide / rail overlap is required.

The anchorages shall be capable of withstanding the loads applied to the seat belt system using a device as shown in Figure 6.17. The anchorages shall be capable of these test loads applied with the seat adjusted in the worst position of the longitudinal adjustment to ensure that the test condition is met. The test loads shall be applied with the seat in the mid-position of the longitudinal adjustment if a worst position among the possible seat adjustments is not recognised by the testing station. For a suspended seat, the seat shall be set to the midpoint of the suspension travel, unless this is contradictory to a clearly stated instruction by the seat manufacturer. Where special instructions exist for the seat setting, these shall be observed and specified in the report.

After the load is applied to the seat system, the load application device shall not be repositioned to compensate for any changes that may occur to the load application angle.

#### 3.7.3.1 Forward loading

A tensile force shall be applied in a forward and upward direction at an angle of  $45^\circ \pm 2^\circ$  to the horizontal, as shown in Figure 6.18. The anchorages shall be capable of withstanding a force of 4 450 N. In the event that the force applied to the seat belt assembly is transferred to the vehicle chassis by means of the seat, the seat mounting shall be capable of withstanding this force plus an additional force equal to four times the force of gravity on the mass of all applicable seat components, applied  $45^\circ \pm 2^\circ$  to the horizontal in a forward and upward direction, as shown in Figure 6.18.

#### 3.7.3.2 Rearward loading

A tensile force shall be applied in a rearward and upward direction at an angle of  $45^\circ \pm 2^\circ$  to the horizontal, as shown in Figure 6.19. The anchorages shall be capable of withstanding a force of 2 225 N. In the event that the force applied to the seat belt assembly is transferred to the vehicle chassis by means of the seat, the seat mounting shall be capable of withstanding this force plus an additional force equal to two times the force of gravity on the mass of all applicable seat components, applied  $45^\circ \pm 2^\circ$  to the horizontal in a rearward and upward direction, as shown in Figure 6.19.

Both tensile forces shall be equally divided between the anchorages.

#### 3.7.3.3 Seatbelt buckle release force (if required by the manufacturer)

The seat belt buckle shall open with a maximum force of 140 N following the load applications. This requirement is fulfilled for seat belt assemblies that satisfy the requirements of UN-ECE R-16 or Directive 77/541/EEC as last amended.

### 3.7.4. Test result

#### Condition of acceptance

Permanent deformation of any system component and anchorage area is acceptable under the action of the forces specified in 3.7.3.1 and 3.7.3.2. However, there shall be no failure allowing release of the seat belt system, seat assembly, or the seat adjustment locking mechanism.

The seat adjuster or locking device need not be operable after application of the test load.

The results of a test performed on an identical “operator restraint system” may be included in more than one test report provided that this system is fitted exactly in the same conditions.

The results of a test performed after the approval of the test report of the protective structure shall be drafted in a technical extension report.

## 3.8 *Foldable ROPS performance (optional)*

### 3.8.1 Scope

This recommended procedure provides minimum performance and tests requirements for front mounted foldable ROPS

- raised and/or lowered manually by a standing operator (with or without partial assistance),
- locked manually or automatically.

### 3.8.2 Explanation of terms used in the performance testing:

3.8.2.1 *hand-operated foldable ROPS* is a front mounted dual pillar protective structure with hand raising/lowering directly managed by the operator (with or without partial assistance).

3.8.2.2 *automatic foldable ROPS* is a front mounted dual pillar protective structure with full assisted raising/lowering operations.

3.8.2.3 *locking system* is a device fitted to lock, by hand or automatically, the ROPS in the raised or lowered positions.

3.8.2.4 *grasping area* is defined by the manufacturer as a portion of the ROPS and/or additional handle fitted to the ROPS where the operator is allowed to carry out the raising/lowering operations.

3.8.2.5 *accessible part of the grasping area* is intended as the area where the ROPS is handled by the operator during the raising/lowering operations. This area shall be defined with regard to the geometric center of cross sections of the grasping area.

3.8.2.6 *accessible zone* is the volume where a standing operator can apply a force in order to raise/lower the ROPS.

3.8.2.6 *pinching point* is a dangerous point where parts move in relation to each other or to fixed parts in such a way as may cause persons or certain parts of their bodies to be pinched.

3.8.2.6 *shear point* is a dangerous point where parts move along each other or along other parts in such a way as may cause persons or certain parts of their bodies to be pinched or shorn.

### 3.8.3 Hand-operated foldable ROPS

#### 3.8.3.1 Prior conditions for the test

The manual handling shall be done by a standing operator with one or more grasps on grasping area of the roll-bar. This area has to be designed without sharp edges, sharp angles and rough surfaces likely to cause injury to the operator.

The grasping area shall be clearly and permanently identified (Figure 6.20).

This area could be on one or both sides of the tractor and could be a structural part of the roll-bar or additional handles. In this grasping area the manual handling to raise or lower the roll-bar shall not create shearing, pinching or uncontrollable movement hazards to the operator (Additional requirement).

Three accessible zones with different amount of allowed force are defined with respect to horizontal plane of the ground and the vertical planes tangent to the outer parts of the tractor that limit the position or the displacement of the operator (Figure 6.21).

Zone I: comfort zone

Zone II : accessible zone without forward leaning of the body

Zone III: accessible zone with forward leaning of the body

The position and the movement of the operator are limited by obstacles. These are parts of the tractor and are defined by vertical planes tangent to the external edges of the obstacle.

If the operator needs to move the feet during the manual handling of the roll-bar a displacement is allowed either within a parallel plane to the roll-bar trajectory or within just one more parallel plane to the previous one so as to overcome an obstacle. The overall displacement shall be considered as a combination of straits lines parallel and perpendicular to the roll-bar trajectory. A perpendicular displacement is accepted provided that the operator comes closer to the roll-bar. The accessible area shall be considered as the envelope of the different accessible zones (Figure 6.22).

The tractor must be fitted with tyres having the greatest diameter indicated by the manufacturer and the smallest cross-section for tyres of that diameter. The tyres must be inflated to the pressure recommended for field work.

The rear wheels must be set to the narrowest track width; the front wheels must be set as closely as possible to the same track width. If it is possible to have two front track settings which differ equally from the narrowest rear track setting, the wider of these two front track settings must be selected.

### 3.8.3.2 Test procedure

Aim of the test is to measure the force necessary to raise or lower the roll-bar. The test will be carried out in static condition: no initial movement of the roll-bar. Each measurement of the force necessary to raise or lower the roll-bar shall be made in a direction tangent to the trajectory of the roll-bar and passing through the geometric center of cross sections of the grasping area.

The grasping area is considered accessible when located within the accessible zones or the envelope of different accessible zones (Figure 6.23).

The force necessary to raise and lower the roll-bar shall be measured in different points that are within the accessible part of the grasping area (Figure 6.24).

The first measure is carried out at the extremity of the accessible part of the grasping area when the roll-bar is fully lowered (Point A). The second is defined according to the position of Point A after rotation of the roll-bar up to the top of the accessible part of the grasping area (Point A').

If in the second measure the roll-bar is not fully raised, an additional point shall be measured at the extremity of the accessible part of the grasping area when the roll-bar is fully raised (Point B).

If between the first two measures the trajectory of the first point crosses the limit between Zone I and Zone II a measurement shall be made at this crossing point (Point A").

In order to measure the force in the required points, it is possible either to measure directly the value or to measure the torque needed to raise or lower the roll-bar so as to calculate the force.

### 3.8.3.3 Condition of acceptance

#### 3.8.3.3.1 Force requirement

The force acceptable for the actuation of the ROPS depends on the accessible zone as shown in Table 6.2.

Zone	I	II	III
Acceptable force (N)	100	75	50

Table 6.2:  
**Allowed forces**

An increase of no more than 25% of these acceptable forces is allowed when the roll-bar is fully lowered and fully raised.

An increase of no more than 50% of these acceptable forces is allowed in the lowering operation.

#### 3.8.3.3.2 Additional requirement

The manual handling to raise or lower the roll-bar shall not create shearing, pinching or uncontrollable movement hazards to the operator

A pinching point is not considered dangerous for the operator hands part if in the grasping area the safety distances between the roll-bar and fixed parts of the tractor are no less than 100 mm for hand, wrist, fist and 25 mm for finger (ISO 13854:2017). The safety distances shall be checked with respect to the mode of handling foreseen by the manufacturer in the operator's manual.

#### 3.8.4. Hand locking system

The device fitted to lock the ROPS in the upright/lowered position must be designed:

- to be handled by one standing operator and located in one of the accessible zones;
- to be hardly separated from the ROPS (for example captive pins as locking pins or retaining pins);
- to avoid any confusion in the locking operation (the proper location of the pins shall be indicated);
- to avoid unintentional removing or losing of parts.

If the devices employed to lock the ROPS in the upright/lowered position are pins they shall be inserted or removed freely. If to do this there is a need to apply a force on the roll-bar this shall comply with the requirements of points A and B (see 3.8.3).

For all other locking devices, they shall be engineered according to an ergonomic approach for what concerns the shape and the force especially avoiding pinching or shearing hazards.

#### 3.8.5. Preliminary test of automatic locking system

An automatic locking system fitted on hand-operated foldable ROPS shall be submitted to a preliminary test before the ROPS strength test.

The roll-bar shall be moved from the lower position to the upright locked position and back. These operations correspond to one cycle. 500 cycles shall be completed.

This could be done manually or with the use of external energy (hydraulic, pneumatic or electric actuators). In both cases the force shall be applied within a plane parallel to the trajectory of the roll-bar and passing through the grasping area, the angular speed of the roll-bar shall be roughly constant and less than 20 deg/s.

After the 500 cycles, the force applied when the roll-bar is in the upright position shall not exceed by more than 50 % the allowed force (Table 6.2).

The unlocking of the roll-bar shall be done following the operator manual.

After the completion of the 500 cycles there shall be no maintenance or adjustment on the locking system,

Note 1: The preliminary test could be applied to automatic foldable ROPS systems as well. The test should be carried out before the ROPS strength test.

Note 2: The preliminary test could be carried out by the manufacturer. In such a case the manufacturer shall provide the test station with a certificate stating that the test has been done according the test procedure and that there were no maintenance or adjustment on the locking system after the completion of the 500 cycles. The test station will check the performance of the device with one cycle from the lower position to the upright locked position and back.

**Computer programme (BASIC) for determining the continuous or interrupted roll-over behaviour  
in case of a laterally overturning narrow-track tractor  
with a protective frame mounted in front of the driver's seat**

**Preliminary note:** The following programme is valid for its calculation methods. Presentation of the printed text as proposed (English language and layout) is indicative; the user will adapt the programme to available printing and other requirements specific to the testing station.

```

10 CLS
20 REM REFERENCE OF THE PROGRAM COD6ABAS.BAS 08/02/96
30 FOR I = 1 TO 10: LOCATE I, 1, 0: NEXT I
40 COLOR 14, 8, 4
50 PRINT "*****"
60 PRINT "*   CALCULATION FOR DETERMINING THE NON-CONTINUOUS ROLLING BEHAVIOUR   *"
70 PRINT "*OF A LATERAL OVERTURNING NARROW TRACTOR WITH A ROLL-OVER PROTECTIVE   *"
80 PRINT "*                               STRUCTURE MOUNTED IN FRONT OF THE DRIVER'S SEAT                               *"
90 PRINT "*****"
100 A$ = INKEY$: IF A$ = "" THEN 100
110 COLOR 10, 1, 4
120 DIM F(25), C(25), CAMPOS(25), LON(25), B$(25), C$(25), X(6, 7), Y(6, 7), Z(6, 7)
130 DATA 6,10,10,14,14,17,19,21,11,11,12,12,13,13,14,14,15,15,16,16,17,17,18,18,19
140 DATA 54,8,47,8,47,12,8,12,29,71,29,71,29,71,29,71,29,71,29,71,29,71,29,71,29
150 DATA 12,30,31,30,31,25,25,25,9,9,9,9,9,9,9,9,9,9,9,9,9,9,9,9,9
160 FOR I = 1 TO 25: READ F(I): NEXT
170 FOR I = 1 TO 25: READ C(I): NEXT
180 FOR I = 1 TO 25: READ LON(I): NEXT
190 CLS
200 FOR I = 1 TO 5: LOCATE I, 1, 0: NEXT I
210 PRINT "In case of misprint, push on the enter key up to the last field"
220 PRINT :LOCATE 6, 44: PRINT " TEST NR: ": PRINT
230 LOCATE 8, 29: PRINT " FRONT MOUNTED- PROTECTIVE STRUCTURE:": PRINT
240 PRINT " MAKE: ": LOCATE 10, 40: PRINT " TYPE: ": PRINT
250 LOCATE 12, 29: PRINT " TRACTOR ": PRINT : PRINT " MAKE: "
260 LOCATE 14, 40: PRINT " TYPE: ": PRINT : PRINT
270 PRINT " LOCATION: ": PRINT
280 PRINT " DATE: ": PRINT : PRINT " ENGINEER: "
290 NC = 1: GOSUB 4400
300 PRINT : PRINT : PRINT " In case of misprint, it is possible to acquire the data again"
310 PRINT : INPUT " Do you wish to acquire again the data ? (Y/N)"; Z$
320 IF Z$ = "Y" OR Z$ = "y" THEN 190
330 IF Z$ = "N" OR Z$ = "n" THEN 340
340 FOR I=1 TO 3:LPRINT : NEXT: LPRINT ; " TEST NR: "; TAB(10); CAMPOS(1)
350 LPRINT : LPRINT TAB(24); " FRONT MOUNTED PROTECTIVE STRUCTURE:"
360 LL = LEN(CAMPOS(2) + CAMPOS(3))
370 LPRINT TAB(36 - LL / 2); CAMPOS(2) + " - " + CAMPOS(3) : LPRINT
380 LPRINT TAB(32); " OF THE NARROW TRACTOR": LL = LEN(CAMPOS(4) + CAMPOS(5))
390 LPRINT TAB(36 - LL / 2); CAMPOS(4) + " - " + CAMPOS(5) : LPRINT
400 CLS
410 PRINT "In case of mistype, push on the enter key up to the last field"
420 PRINT
430 FOR I = 1 TO 7: LOCATE I, 1, 0: NEXT
440 LOCATE 8, 1: PRINT " CHARACTERISTIC UNITS: "
450 LOCATE 8, 29: PRINT "LINEAR (m): MASS (kg):MOMENT OF INERTIA (kg·m2):"

```



```

460 LOCATE 9, 1: PRINT "                ANGLE (radian)"
470 LPRINT : PRINT
480 PRINT "HEIGHT OF COG      H1=": LOCATE 11, 29: PRINT "      "
490 LOCATE 11, 40: PRINT "H. DIST. COG-REAR AXLE  L3="
500 LOCATE 11, 71: PRINT "      "
510 PRINT "H. DIST. COG-FRT AXLE  L2=": LOCATE 12, 29: PRINT "      "
520 LOCATE 12, 40: PRINT "HEIGHT OF THE REAR TYRES  D3="
530 LOCATE 12, 71: PRINT "      "
540 PRINT "HEIGHT OF THE FRT TYRES  D2=": LOCATE 13, 29: PRINT "      "
550 LOCATE 13, 40: PRINT "OVERALL HEIGHT(PT IMPACT) H6="
560 LOCATE 13, 71: PRINT "      "
570 PRINT "H.DIST.COG-LEAD.PT INTER.L6=": LOCATE 14, 29: PRINT "      "
580 LOCATE 14, 40: PRINT "PROTECTIVE STRUCT. WIDTH  B6="
590 LOCATE 14, 71: PRINT "      "
600 PRINT "HEIGHT OF THE ENG.B.  H7=": LOCATE 15, 29: PRINT "      "
605 LOCATE 15, 40: PRINT "WIDTH OF THE ENG. B.  B7="
610 LOCATE 15, 71: PRINT "      "
615 PRINT "H.DIST.COG-FRT COR.ENG.B.L7=": LOCATE 16, 29: PRINT "      "
620 LOCATE 16, 40: PRINT "HEIGHT FRT AXLE PIVOT PT  H0="
630 LOCATE 16, 71: PRINT "      "
640 PRINT "REAR TRACK WIDTH      S=": LOCATE 17, 29: PRINT "      "
650 LOCATE 17, 40: PRINT "REAR TYRE WIDTH      B0="
660 LOCATE 17, 71: PRINT "      "
670 PRINT "FRT AXLE SWING ANGLE  D0=": LOCATE 18, 29: PRINT "      "
680 LOCATE 18, 40: PRINT "TRACTOR MASS      Mc ="
690 LOCATE 18, 71: PRINT "      "
700 PRINT "MOMENT OF INERTIA      Q=": LOCATE 19, 29: PRINT "      "
710 LOCATE 19, 40: PRINT "      "
720 LOCATE 19, 71: PRINT "      ": PRINT : PRINT
730 H1 = 0: L3 = 0: L2 = 0: D3 = 0: D2 = 0: H6 = 0: L6 = 0: B6 = 0
740 H7 = 0: B7 = 0: L7 = 0: H0 = 0: S = 0: B0 = 0: D = 0: Mc = 0: Q = 0
750 NC = 9: GOSUB 4400
760 FOR I = 1 TO 3: PRINT "": NEXT
770 H1 = VAL(CAMPOS$(9)): L3 = VAL(CAMPOS$(10)): L2 = VAL(CAMPOS$(11))
780 D3 = VAL(CAMPOS$(12)): D2 = VAL(CAMPOS$(13)): H6 = VAL(CAMPOS$(14))
790 L6 = VAL(CAMPOS$(15)): B6 = VAL(CAMPOS$(16)): H7 = VAL(CAMPOS$(17))
800 B7 = VAL(CAMPOS$(18)): L7 = VAL(CAMPOS$(19)): H0 = VAL(CAMPOS$(20))
810 S = VAL(CAMPOS$(21)): B0 = VAL(CAMPOS$(22)): D0 = VAL(CAMPOS$(23))
820 Mc = VAL(CAMPOS$(24)): Q = VAL(CAMPOS$(25)): PRINT : PRINT
830 PRINT "In case of mistype, it is possible to acquire again the data": PRINT
840 INPUT " Do you wish to acquire again the data ? (Y/N)"; X$
850 IF X$ = "Y" OR X$ = "y" THEN 400
860 IF X$ = "n" OR X$ = "N" THEN 870
870 FOR I = 1 TO 3: LPRINT : NEXT
880 LPRINT TAB(20); "CHARACTERISTIC UNITS  ":": LOCATE 8, 29
890 LPRINT "LINEAR (m) : MASS (kg) : MOMENT OF INERTIA (kg-m2) : ANGLE (radian)"
900 LPRINT
910 LPRINT "HEIGHT OF THE COG      H1=";
920 LPRINT USING "#####.#####"; H1;
930 LPRINT TAB(40); "H. DIST. COG-REAR AXLE  L3=";
940 LPRINT USING "#####.#####"; L3
950 LPRINT "H.DIST. COG-FRT AXLE  L2=";
960 LPRINT USING "#####.#####"; L2;
970 LPRINT TAB(40); "HEIGHT OF THE REAR TYRES D3=";
975 LPRINT USING "#####.#####"; D3
980 LPRINT "HEIGHT OF THE FRT TYRES  D2=";

```

```

990 LPRINT USING "####.####"; D2;
1000 LPRINT TAB(40); "OVERALL HEIGHT(PT IMPACT)H6=";
1010 LPRINT USING "####.####"; H6
1020 LPRINT "H.DIST.COG-LEAD PT INTER.L6=";
1030 LPRINT USING "####.####"; L6;
1040 LPRINT TAB(40); "PROTECTIVE STRUCT. WIDTH B6=";
1050 LPRINT USING "####.####"; B6
1060 LPRINT "HEIGHT OF THE ENG.B. H7=";
1070 LPRINT USING "####.####"; H7;
1080 LPRINT TAB(40); "WIDTH OF THE ENG. B. B7=";
1090 LPRINT USING "####.####"; B7
1100 LPRINT "H.DIST.COG-FRT COR.ENG.B.L7=";
1110 LPRINT USING "####.####"; L7;
1120 LPRINT TAB(40); "HEIGHT FRT AXLE PIVOT PT H0=";
1130 LPRINT USING "####.####"; H0
1140 LPRINT "REAR TRACK WIDTH S=";
1150 LPRINT USING "####.####"; S;
1160 LPRINT TAB(40); "REAR TYRE WIDTH B0=";
1170 LPRINT USING "####.####"; B0
1180 LPRINT "FRT AXLE SWING ANGLE D0=";
1185 LPRINT USING "####.####"; D0;
1190 LPRINT TAB(40); "TRACTOR MASS Mc=";
1200 LPRINT USING "####.####"; Mc
1210 LPRINT "MOMENT OF INERTIA Q=";
1215 LPRINT USING "####.####"; Q
1220 FOR I = 1 TO 10: LPRINT : NEXT
1230 A0 = .588: U = .2: T = .2: GOSUB 4860
1240 REM * THE SIGN OF L6 IS MINUS IF THE POINT LIES IN FRONT
1250 REM * OF THE PLANE OF THE CENTRE OF GRAVITY.
1260 IF B6 > S + B0 THEN 3715
1265 IF B7 > S + B0 THEN 3715
1270 G = 9.8
1280 REM *****
1290 REM *B2 VERSION (POINT OF IMPACT OF THE ROPS NEAR OF EQUILIBRIUM POINT)*
1300 REM *****
1310 B = B6: H = H6
1320 REM -----POSITION OF CENTER OF GRAVITY IN TILTED POSITION -----
1330 R2 = SQR(H1 * H1 + L3 * L3)
1340 C1 = ATN(H1 / L3)
1350 L0 = L3 + L2
1360 L9 = ATN(H0 / L0)
1370 H9 = R2 * SIN(C1 - L9)
1380 W1 = H9 / TAN(C1 - L9)
1390 W2 = SQR(H0 * H0 + L0 * L0): S1 = S / 2
1400 F1 = ATN(S1 / W2)
1410 W3 = (W2 - W1) * SIN(F1)
1420 W4 = ATN(H9 / W3)
1430 W5 = SQR(H9 * H9 + W3 * W3) * SIN(W4 + D0)
1440 W6 = W3 - SQR(W3 * W3 + H9 * H9) * COS(W4 + D0)
1450 W7 = W1 + W6 * SIN(F1)
1460 W8 = ATN(W5 / W7)
1470 W9 = SIN(W8 + L9) * SQR(W5 * W5 + W7 * W7)
1480 W0 = SQR(W9 * W9 + (S1 - W6 * COS(F1))^ 2)
1490 G1 = SQR(((S + B0) / 2)^ 2 + H1 * H1)
1500 G2 = ATN(2 * H1 / (S + B0))
1510 G3 = W0 - G1 * COS(A0 + G2)

```

```

1520 O0 = SQR(2 * Mc * G * G3 / (Q + Mc * (W0 + G1) * (W0 + G1) / 4))
1530 F2 = ATN(((D3 - D2) / L0) / (1 - ((D3 - D2) / (2 * L3 + 2 * L2)) ^ 2))
1540 L8 = -TAN(F2) * (H - H1)
1550 REM----- COORDINATES IN POSITION 1 -----
1560 X(1, 1) = H1
1570 X(1, 2) = 0: X(1, 3) = 0
1580 X(1, 4) = (1 + COS(F2)) * D2 / 2
1590 X(1, 5) = (1 + COS(F2)) * D3 / 2
1600 X(1, 6) = H
1610 X(1, 7) = H7
1620 Y(1, 1) = 0
1630 Y(1, 2) = L2
1640 Y(1, 3) = -L3
1650 Y(1, 4) = L2 + SIN(F2) * D2 / 2
1660 Y(1, 5) = -L3 + SIN(F2) * D3 / 2
1670 Y(1, 6) = -L6
1680 Y(1, 7) = L7
1690 Z(1, 1) = (S + B0) / 2
1700 Z(1, 2) = 0: Z(1, 3) = 0: Z(1, 4) = 0: Z(1, 5) = 0
1710 Z(1, 6) = (S + B0) / 2 - B / 2
1720 Z(1, 7) = (S + B0) / 2 - B7 / 2
1730 O1 = 0: O2 = 0: O3 = 0: O4 = 0: O5 = 0: O6 = 0: O7 = 0: O8 = 0: O9 = 0
1740 K1 = Y(1, 4) * TAN(F2) + X(1, 4)
1750 K2 = X(1, 1)
1760 K3 = Z(1, 1)
1770 K4 = K1 - X(1, 1): DD1 = Q + Mc * K3 * K3 + Mc * K4 * K4
1780 O1 = (Q + Mc * K3 * K3 - U * Mc * K4 * K4 - (1 + U) * Mc * K2 * K4) * O0 / DD1
1790 REM---TRANSFORMATION OF THE COORDINATES FROM THE POSITION 1 TO 2
1800 FOR K = 1 TO 7 STEP 1
1810 X(2, K) = COS(F2) * (X(1, K) - H1) + SIN(F2) * Y(1, K) - K4 * COS(F2)
1820 Y(2, K) = Y(1, K) * COS(F2) - (X(1, K) - H1) * SIN(F2)
1830 Z(2, K) = Z(1, K)
1840 NEXT K
1850 O2 = O1 * COS(F2)
1860 A2 = ATN(TAN(A0) / SQR(1 + (TAN(F2)) ^ 2 / (COS(A0)) ^ 2))
1870 C2 = ATN(Z(2, 6) / X(2, 6))
1880 T2 = T
1890 V0 = SQR(X(2, 6) ^ 2 + Z(2, 6) ^ 2)
1900 E1 = T2 / V0
1910 E2 = (V0 * Y(2, 4)) / (Y(2, 4) - Y(2, 6))
1920 T3 = E1 * E2
1930 E4 = SQR(X(2, 1) * X(2, 1) + Z(2, 1) * Z(2, 1))
1940 V6 = ATN(X(2, 1) / Z(2, 1))
1950 REM-----ROTATION OF THE TRACTOR FROM THE POSITION 2 TO 3 ---
1960 FOR K = 1 TO 7 STEP 1
1970 IF Z(2, K) = 0 THEN 2000
1980 E3 = ATN(X(2, K) / Z(2, K))
1990 GOTO 2010
2000 E3 = -3.14159 / 2
2010 X(3, K) = SQR(X(2, K) * X(2, K) + Z(2, K) * Z(2, K)) * SIN(E3 + C2 + E1)
2020 Y(3, K) = Y(2, K)
2030 Z(3, K) = SQR(X(2, K) ^ 2 + Z(2, K) ^ 2) * COS(E3 + C2 + E1)
2040 NEXT K
2050 IF Z(3, 7) < 0 THEN 3680
2060 Z(3, 6) = 0
2070 Q3 = Q * (COS(F2)) ^ 2 + 3 * Q * (SIN(F2)) ^ 2

```

**CODE 6 – February 2024**

```

2080 V5 = (Q3 + Mc * E4 * E4) * O2 * O2 / 2
2090 IF -V6 > A2 THEN 2110
2100 GOTO 2130
2110 V7 = E4 * (1 - COS(-A2 - V6))
2120 IF V7 * Mc * G > V5 THEN 2320
2130 V8 = E4 * COS(-A2 - V6) - E4 * COS(-A2 - ATN(X(3, 1) / Z(3, 1)))
2140 O3 = SQR(2 * Mc * G * V8 / (Q3 + Mc * E4 * E4) + O2 * O2)
2150 K9 = X(3, 1)
2160 K5 = Z(3, 1)
2170 K6 = Z(3, 1) + E1 * V0
2180 K7 = V0 - X(3, 1)
2190 K8 = U: DD2 = Q3 + Mc * K6 * K6 + Mc * K7 * K7
2200 O4 = (Q3 + Mc * K5 * K6 - K8 * Mc * K7 * K7 - (1 + K8) * Mc * K9 * K7) * O3 / DD2
2210 N3 = SQR((X(3, 6) - X(3, 1)) ^ 2 + (Z(3, 6) - Z(3, 1)) ^ 2)
2220 N2 = ATN(-(X(3, 6) - X(3, 1)) / Z(3, 1))
2230 Q6 = Q3 + Mc * N3 ^ 2
2240 IF -N2 <= A2 THEN 2290
2250 N4 = N3 * (1 - COS(-A2 - N2))
2260 N5 = (Q6) * O4 * O4 / 2
2270 IF N4 * Mc * G > N5 THEN 2320
2280 O9 = SQR(-2 * Mc * G * N4 / (Q6) + O4 * O4)
2290 GOSUB 3740
2300 GOSUB 4170
2310 GOTO 4330
2320 GOSUB 3740
2330 IF L6 > L8 THEN 2790
2340 REM *
2350 REM *****
2355 REM *B3 VERSION (POINT OF IMPACT OF THE ROPS IN FRONT OF EQUILIBRIUM POINT)*
2360 REM *****
2370 O3 = 0: O4 = 0: O5 = 0: O6 = 0: O7 = 0: O8 = 0: O9 = 0
2380 E2 = (V0 * Y(2, 5)) / (Y(2, 5) - Y(2, 6))
2390 T3 = E2 * E1
2400 Z(3, 6) = 0
2410 Q3 = Q * (COS(F2)) ^ 2 + 3 * Q * (SIN(F2)) ^ 2
2420 V5 = (Q3 + Mc * E4 * E4) * O2 * O2 / 2
2430 IF -V6 > A2 THEN 2450
2440 GOTO 2470
2450 V7 = E4 * (1 - COS(-A2 - V6))
2460 IF V7 * Mc * G > V5 THEN 2760
2470 V8 = E4 * COS(-A2 - V6) - E4 * COS(-A2 - ATN(X(3, 1) / Z(3, 1)))
2480 O3 = SQR((2 * Mc * G * V8) / (Q3 + Mc * E4 * E4) + O2 * O2)
2490 K9 = X(3, 1)
2500 K5 = Z(3, 1)
2510 K6 = Z(3, 1) + T3
2520 K7 = E2 - X(3, 1)
2530 K8 = U: DD2 = Q3 + Mc * K6 * K6 + Mc * K7 * K7
2540 O4 = (Q3 + Mc * K5 * K6 - K8 * Mc * K7 * K7 - (1 + K8) * Mc * K9 * K7) * O3 / DD2
2550 F3 = ATN(V0 / (Y(3, 5) - Y(3, 6)))
2560 O5 = O4 * COS(F3)
2570 REM-----TRANSFORMATION OF THE COORDINATES FROM THE POSITION 3 TO 4 ----
2580 REM-----POSITION 4
2590 FOR K = 1 TO 7 STEP 1
2600 X(4, K) = X(3, K) * COS(F3) + (Y(3, K) - Y(3, 5)) * SIN(F3)
2610 Y(4, K) = (Y(3, K) - Y(3, 5)) * COS(F3) - X(3, K) * SIN(F3)
2620 Z(4, K) = Z(3, K)

```

```

2630 NEXT K
2640 A4 = ATN(TAN(A0) / SQR(1 + (TAN(F2 + F3)) ^ 2 / (COS(A0)) ^ 2))
2650 M1 = SQR(X(4, 1) ^ 2 + Z(4, 1) ^ 2)
2660 M2 = ATN(X(4, 1) / Z(4, 1))
2670 Q5 = Q * (COS(F2 + F3)) ^ 2 + 3 * Q * (SIN(F2 + F3)) ^ 2
2680 IF -M2 < A4 THEN 2730
2690 M3 = M1 * (1 - COS(-A4 - M2))
2700 M4 = (Q5 + Mc * M1 * M1) * O5 * O5 / 2
2710 IF M3 * Mc * G > M4 THEN 2760
2720 O9 = SQR(O5 * O5 - 2 * Mc * G * M3 / (Q5 + Mc * M1 * M1))
2730 GOSUB 3740
2740 GOSUB 4170
2750 GOTO 4330
2760 GOSUB 3740
2770 GOSUB 4240
2780 GOTO 4330
2790 REM *****
2795 REM *B1 VERSION (POINT OF IMPACT OF THE ROPS BEHIND OF EQUILIBRIUM POINT)*
2800 REM *****
2810 REM *
2820 O3 = 0: O4 = 0: O5 = 0: O6 = 0: O7 = 0: O8 = 0: O9 = 0
2830 Z(3, 6) = 0
2840 Q3 = Q * (COS(F2)) ^ 2 + 3 * Q * (SIN(F2)) ^ 2
2850 V5 = (Q3 + Mc * E4 * E4) * O2 * O2 / 2
2860 IF -V6 > A2 THEN 2880
2870 GOTO 2900
2880 V7 = E4 * (1 - COS(-A2 - V6))
2890 IF V7 * Mc * G > V5 THEN 3640
2900 V8 = E4 * COS(-A2 - V6) - E4 * COS(-A2 - ATN(X(3, 1) / Z(3, 1)))
2910 O3 = SQR(2 * Mc * G * V8 / (Q3 + Mc * E4 * E4) + O2 * O2)
2920 K9 = X(3, 1)
2930 K5 = Z(3, 1)
2940 K6 = Z(3, 1) + T3
2950 K7 = E2 - X(3, 1)
2960 K8 = U: DD2 = Q3 + Mc * K6 * K6 + Mc * K7 * K7
2970 O4 = (Q3 + Mc * K5 * K6 - K8 * Mc * K7 * K7 - (1 + K8) * Mc * K9 * K7) * O3 / DD2
2980 F3 = ATN(V0 / (Y(3, 4) - Y(3, 6)))
2990 O5 = O4 * COS(F3)
3000 REM----TRANSFORMATION OF THE COORDINATES FROM 3 TO 4 ---
3010 FOR K = 1 TO 7 STEP 1
3020 X(4, K) = X(3, K) * COS(F3) + (Y(3, K) - Y(3, 4)) * SIN(F3)
3030 Y(4, K) = (Y(3, K) - Y(3, 4)) * COS(F3) - X(3, K) * SIN(F3)
3040 Z(4, K) = Z(3, K)
3050 NEXT K
3060 A4 = ATN(TAN(A0) / SQR(1 + (TAN(F2 + F3)) ^ 2 / (COS(A0)) ^ 2))
3070 C3 = ATN(Z(4, 7) / X(4, 7))
3080 C4 = 0
3090 C5 = SQR(X(4, 7) * X(4, 7) + Z(4, 7) * Z(4, 7))
3100 C6 = C4 / C5
3110 C7 = C5 * (Y(4, 6) - Y(4, 1)) / (Y(4, 6) - Y(4, 7))
3120 C8 = C6 * C7
3130 M1 = SQR(X(4, 1) ^ 2 + Z(4, 1) ^ 2)
3140 M2 = ATN(X(4, 1) / Z(4, 1))
3150 REM ----ROTATION OF THE TRACTOR FROM THE POSITION 4 TO 5 ---
3160 FOR K = 1 TO 7 STEP 1
3170 IF Z(4, K) <> 0 THEN 3200

```

**CODE 6 – February 2024**

```
3180 C9 = -3.14159 / 2
3190 GOTO 3210
3200 C9 = ATN(X(4, K) / Z(4, K))
3210 X(5, K) = SQR(X(4, K) ^ 2 + Z(4, K) ^ 2) * SIN(C9 + C3 + C6)
3220 Y(5, K) = Y(4, K)
3230 Z(5, K) = SQR(X(4, K) ^ 2 + Z(4, K) ^ 2) * COS(C9 + C3 + C6)
3240 NEXT K
3250 Z(5, 7) = 0
3260 Q5 = Q * (COS(F2 + F3)) ^ 2 + 3 * Q * (SIN(F2 + F3)) ^ 2
3270 IF -M2 > A4 THEN 3290
3280 GOTO 3320
3290 M3 = M1 * (1 - COS(-A4 - M2))
3300 M4 = (Q5 + Mc * M1 * M1) * O5 * O5 / 2
3310 IF M3 * Mc * G > M4 THEN 3640
3315 MM1 = M1 * COS(-A4 - ATN(X(5, 1) / Z(5, 1)))
3320 M5 = M1 * COS(-A4 - ATN(X(4, 1) / Z(4, 1))) - MM1
3330 O6 = SQR(2 * Mc * G * M5 / (Q5 + Mc * M1 * M1) + O5 * O5)
3340 M6 = X(5, 1)
3350 M7 = Z(5, 1)
3360 M8 = Z(5, 1) + C8
3370 M9 = C7 - X(5, 1)
3380 N1 = U: DD3 = (Q5 + Mc * M8 * M8 + Mc * M9 * M9)
3390 O7 = (Q5 + Mc * M7 * M8 - N1 * Mc * M9 * M9 - (1 + N1) * Mc * M6 * M9) * O6 / DD3
3400 F5 = ATN(C5 / (Y(5, 6) - Y(5, 7)))
3410 A6 = ATN(TAN(A0) / SQR(1 + (TAN(F2 + F3 + F5)) ^ 2 / (COS(A0)) ^ 2))
3420 REM----TRANSFORMATION OF THE COORDINATES FROM THE POSITION 5 TO 6 ---
3430 FOR K = 1 TO 7 STEP 1
3440 X(6, K) = X(5, K) * COS(F5) + (Y(5, K) - Y(5, 6)) * SIN(F5)
3450 Y(6, K) = (Y(5, K) - Y(5, 6)) * COS(F5) - X(5, K) * SIN(F5)
3460 Z(6, K) = Z(5, K)
3470 NEXT K
3480 O8 = O7 * COS(-F5)
3490 N2 = ATN(X(6, 1) / Z(6, 1))
3500 N3 = SQR(X(6, 1) ^ 2 + Z(6, 1) ^ 2)
3510 Q6 = Q * (COS(F2 + F3 + F5)) ^ 2 + 3 * Q * (SIN(F2 + F3 + F5)) ^ 2
3520 IF -N2 > A6 THEN 3540
3530 GOTO 3580
3540 N4 = N3 * (1 - COS(-A6 - N2))
3550 N5 = (Q6 + Mc * N3 * N3) * O8 * O8 / 2
3560 P9 = (N4 * Mc * G - N5) / (N4 * Mc * G)
3570 IF N4 * Mc * G > N5 THEN 3640
3580 IF -N2 < A6 THEN 3610
3590 N6 = -N4
3600 O9 = SQR(2 * Mc * G * N6 / (Q6 + Mc * N3 * N3) + O8 * O8)
3610 GOSUB 3740
3620 GOSUB 4170
3630 GOTO 4330
3640 GOSUB 3740
3650 GOSUB 4240
3660 GOTO 4330
3670 REM
3680 IF Z(3, 7) > -.2 THEN 2060
3685 CLS : PRINT : PRINT : PRINT STRING$(80, 42): LOCATE 24, 30, 0
3690 PRINT " THE ENGINE BONNET TOUCHES THE GROUND BEFORE THE ROPS"
3695 LPRINT STRING$(80, 42)
3700 LPRINT "THE ENGINE BONNET TOUCHES THE GROUND BEFORE THE ROPS "
```

```

3710 PRINT : PRINT " METHOD OF CALCULATION NOT FEASIBLE" : GOTO 3720
3715 CLS : PRINT : PRINT " METHOD OF CALCULATION NOT FEASIBLE"
3720 LPRINT "METHOD OF CALCULATION NOT FEASIBLE "
3725 LPRINT STRING$(80, 42)
3730 GOTO 4330
3740 REM *****
3750 CLS : LOCATE 13, 15, 0: PRINT "VELOCITY O0="
3755 LOCATE 13, 31, 0: PRINT USING "#.###"; O0: LOCATE 13, 40, 0: PRINT "rad/s"
3760 LOCATE 14, 15, 0: PRINT "VELOCITY O1="
3765 LOCATE 14, 31, 0: PRINT USING "#.###"; O1
3770 LOCATE 15, 15, 0: PRINT "VELOCITY O2="
3775 LOCATE 15, 31, 0: PRINT USING "#.###"; O2
3780 LOCATE 16, 15, 0: PRINT "VELOCITY O3="
3785 LOCATE 16, 31, 0: PRINT USING "#.###"; O3
3790 LOCATE 17, 15, 0: PRINT "VELOCITY O4="
3795 LOCATE 17, 31, 0: PRINT USING "#.###"; O4
3800 LOCATE 18, 15, 0: PRINT "VELOCITY O5="
3805 LOCATE 18, 31, 0: PRINT USING "#.###"; O5
3810 LOCATE 19, 15, 0: PRINT "VELOCITY O6="
3815 LOCATE 19, 31, 0: PRINT USING "#.###"; O6
3820 LOCATE 20, 15, 0: PRINT "VELOCITY O7="
3825 LOCATE 20, 31, 0: PRINT USING "#.###"; O7
3830 LOCATE 21, 15, 0: PRINT "VELOCITY O8="
3835 LOCATE 21, 31, 0: PRINT USING "#.###"; O8
3840 LOCATE 22, 15, 0: PRINT "VELOCITY O9="
3845 LOCATE 22, 31, 0: PRINT USING "#.###"; O9
3850 LPRINT "VELOCITY O0=";
3860 LPRINT USING "#.###"; O0;
3870 LPRINT " rad/s";
3880 LPRINT TAB(40); "VELOCITY O1=";
3890 LPRINT USING "#.###"; O1;
3900 LPRINT " rad/s"
3910 LPRINT "VELOCITY O2=";
3920 LPRINT USING "#.###"; O2;
3930 LPRINT " rad/s";
3940 LPRINT TAB(40); "VELOCITY O3=";
3950 LPRINT USING "#.###"; O3;
3960 LPRINT " rad/s"
3970 LPRINT "VELOCITY O4=";
3980 LPRINT USING "#.###"; O4;
3990 LPRINT " rad/s";
4000 LPRINT TAB(40); "VELOCITY O5=";
4010 LPRINT USING "#.###"; O5;
4020 LPRINT " rad/s"
4030 LPRINT "VELOCITY O6=";
4040 LPRINT USING "#.###"; O6;
4050 LPRINT " rad/s";
4060 LPRINT TAB(40); "VELOCITY O7=";
4070 LPRINT USING "#.###"; O7;
4080 LPRINT " rad/s"
4090 LPRINT "VELOCITY O8=";
4100 LPRINT USING "#.###"; O8;
4110 LPRINT " rad/s";
4120 LPRINT TAB(40); "VELOCITY O9=";
4130 LPRINT USING "#.###"; O9;
4140 LPRINT " rad/s"

```

**CODE 6 – February 2024**

```
4150 LPRINT
4160 RETURN
4170 PRINT STRING$(80, 42)
4180 LOCATE 24, 30, 0: PRINT "THE TILTING CONTINUES"
4190 PRINT STRING$(80, 42)
4200 LPRINT STRING$(80, 42)
4210 LPRINT TAB(30); "THE TILTING CONTINUES"
4220 LPRINT STRING$(80, 42)
4230 RETURN
4240 PRINT STRING$(80, 42)
4250 LOCATE 24, 30, 0: PRINT "THE ROLLING STOPS"
4260 PRINT STRING$(80, 42)
4270 LPRINT STRING$(80, 42)
4280 LPRINT TAB(30); "THE ROLLING STOPS"
4290 LPRINT STRING$(80, 42)
4300 RETURN
4310 REM *****
4320 REM-----END OF THE CALCULATION-----
4330 FOR I = 1 TO 5: LPRINT : NEXT: LPRINT " LOCATION : "; CAMPOS$(6): LPRINT
4340 LPRINT " DATE : "; CAMPOS$(7): LPRINT
4350 LPRINT ; " ENGINEER : "; CAMPOS$(8): LPRINT
4360 FOR I = 1 TO 4: LPRINT : NEXT: PRINT
4370 INPUT " Do you wish to carry out another test ? (Y/N)"; Y$
4380 IF Y$ = "Y" OR Y$ = "y" THEN 190
4390 IF Y$ = "N" OR Y$ = "n" THEN SYSTEM
4400 LOCATE F(NC), C(NC) + L, 1: A$ = INKEY$: IF A$ = "" THEN GOTO 4400
4410 IF LEN(A$) > 1 THEN GOSUB 4570: GOTO 4400
4420 A = ASC(A$)
4430 IF A = 13 THEN L = 0: GOTO 4450
4440 GOTO 4470
4450 IF NC < 8 OR NC > 8 AND NC < 25 THEN NC = NC + 1: GOTO 4400
4460 GOTO 4840
4470 IF A > 31 AND A < 183 THEN GOTO 4490
4480 BEEP: GOTO 4400
4490 IF L = LON(NC) THEN BEEP: GOTO 4400
4500 LOCATE F(NC), C(NC) + L: PRINT A$;
4510 L = L + 1
4520 IF L = 1 THEN B$(NC) = A$: GOTO 4540
4530 B$(NC) = B$(NC) + A$
4540 IF LEN(C$(NC)) > 0 THEN C$(NC) = RIGHTS$(CAMPOS$(NC), LEN(CAMPOS$(NC)) - L)
4550 CAMPOS$(NC) = B$(NC) + C$(NC)
4560 GOTO 4400
4570 REM * SLIDE
4580 IF LEN(A$) <> 2 THEN BEEP: RETURN
4590 C = ASC(RIGHTS$(A$, 1))
4600 IF C = 8 THEN 4620
4610 GOTO 4650
4620 IF LEN(C$(NC)) > 0 THEN BEEP: RETURN
4630 IF L = 0 THEN BEEP: RETURN
4640 CAMPOS$(NC) = LEFT$(CAMPOS$(NC), LEN(CAMPOS$(NC)))
4645 L = L - 1: PRINT A$: RETURN
4650 IF C = 30 THEN 4670
4660 GOTO 4700
4670 IF NC = 1 THEN BEEP: RETURN
4680 NC = NC - 1: L = 0
4690 RETURN
```



```

4700 IF C = 31 THEN 4720
4710 GOTO 4760
4720 IF NC <> 8 THEN 4740
4730 BEEP: RETURN
4740 NC = NC + 1: L = 0
4750 RETURN
4760 IF C = 29 THEN 4780
4770 GOTO 4800
4780 IF L = 0 THEN BEEP: RETURN
4790 L = L - 1: C$(NC) = RIGHT$(CAMPOS$(NC), LEN(CAMPOS$(NC)) - (L + 1))
4795 B$(NC) = LEFT$(CAMPOS$(NC), L): LOCATE F(NC), C(NC) + L + 1: PRINT ""
4796 RETURN
4800 IF C = 28 THEN 4820
4810 GOTO 4400
4820 IF C$(NC) = "" THEN BEEP: RETURN
4830 L = L + 1: C$(NC) = RIGHT$(CAMPOS$(NC), LEN(CAMPOS$(NC)) - (L))
4835 B$(NC) = LEFT$(CAMPOS$(NC), L): LOCATE F(NC), C(NC) + L, 1: PRINT ""
4840 RETURN
4850 RETURN
4860 FOR II = 1 TO 7
4870 X(1, II) = 0: X(2, II) = 0: X(3, II) = 0
4875 X(4, II) = 0: X(5, II) = 0: X(6, II) = 0
4880 Y(1, II) = 0: Y(2, II) = 0: Y(3, II) = 0
4885 Y(4, II) = 0: Y(5, II) = 0: Y(6, II) = 0
4890 Z(1, II) = 0: Z(2, II) = 0: Z(3, II) = 0
4895 Z(4, II) = 0: Z(5, II) = 0: Z(6, II) = 0
4900 NEXT II
4910 RETURN
4920 REM * THE SYMBOLS USED HERE ARE THE SAME AS IN THE CODE 6.

```

**For tractor fitted with tracks, the following lines have to be substituted in the original model:**

```

520 LOCATE 12, 40: PRINT "HEIGHT OF THE REAR TRACKS D3="
*540 PRINT "HEIGHT OF THE FRT TRACKS D2=": LOCATE 13, 29: PRINT " "
650 LOCATE 17, 40: PRINT "REAR TRACKS WIDTH B0="
970 LPRINT TAB(40); "HEIGHT OF THE REAR TRACKS D3=";
*980 LPRINT "HEIGHT OF THE FRT TRACKS D2=";
1160 LPRINT TAB(40); "REAR TRACK WIDTH B0=";
1390 W2 = SQR(H0 * H0 + L0 * L0): S1 = S / 2 + B0 / 2
1530 F2 = 2 * ATN(- L0 / D3 + SQR((L0 / D3) ^ 2 - (D2 / D3) + 1))
1590 X(1, 5) = D3
1660 Y(1, 5) = -L3

```

\* if applicable

TEST NR:

FRONT MOUNTED-OVER PROTECTIVE STRUCTURE  
OF THE NARROW TRACTOR:

CHARACTERISTIC UNITS:

LINEAR (m): MASS (kg):

MOMENT OF INERTIA (kgm<sup>2</sup>): ANGLE (radian)

HEIGHT OF THE COG	H1 = 0.7620	H. DIST. COG-REAR AXLE	L3 = 0.8970
H. DIST. COG - FRONT AXLE	L2 = 1.1490	HEIGHT OF THE REAR TYRES	D3 = 1.2930
HEIGHT OF THE FRT TYRES	D2 = 0.8800	OVERALL HEIGHT( PT IMPACT)	H6 = 2.1000
H. DIST. COG-LEAD PT INTER.	L6 = 0.2800	PROTECTIVE STRUCT. WIDTH	B6 = 0.7780
HEIGHT OF THE ENG. B.	H7 = 1.3370	WIDTH OF THE ENG. B.	B7 = 0.4900
H. DIST. COG-FRT COR. ENG. B.	L7 = 1.6390	HEIGHT FRT AXLE PIVOT PT	H0 = 0.4450
REAR TRACK WIDTH	S = 1.1150	REAR TYRE WIDTH	B0 = 0.1950
FRT AXLE SWING ANGLE	D0 = 0.1570	TRACTOR MASSM <sub>c</sub> = 2565.000	
MOMENT OF INERTIA	Q = 295.0000		

VELOCITY O0 = 3.881 rad/s  
VELOCITY O2 = 1.057 rad/s  
VELOCITY O4 = 0.731 rad/s  
VELOCITY O6 = 0.000 rad/s  
VELOCITY O8 = 0.000 rad/s

VELOCITY O1 = 1.078 rad/s  
VELOCITY O3 = 2.134 rad/s  
VELOCITY O5 = 0.000 rad/s  
VELOCITY O7 = 0.000 rad/s  
VELOCITY O9 = 0.000 rad/s

VELOCITY O0 = 3.881 rad/s  
VELOCITY O2 = 1.057 rad/s  
VELOCITY O4 = 1.130 rad/s  
VELOCITY O6 = 0.810 rad/s  
VELOCITY O8 = 0.587 rad/s

VELOCITY O1 = 1.078 rad/s  
VELOCITY O3 = 2.134 rad/s  
VELOCITY O5 = 0.993 rad/s  
VELOCITY O7 = 0.629 rad/s  
VELOCITY O9 = 0.219 rad/s

THE TILTING CONTINUES

Location:      Date:      Engineer:

Example 6.1

**The tilting continues**

TEST NR:

FRONT MOUNTED-OVER PROTECTIVE STRUCTURE  
OF THE NARROW TRACTOR:

CHARACTERISTIC UNITS:

LINEAR (m): MASS (kg):

MOMENT OF INERTIA (kgm<sup>2</sup>): ANGLE (radian)

HEIGHT OF THE COG	H1 = 0.7653	H. DIST. COG-REAR AXLE	L3 = 0.7970
H. DIST. COG - FRONT AXLE	L2 = 1.1490	HEIGHT OF THE REAR TYRES	D3 = 1.4800
HEIGHT OF THE FRT TYRES	D2 = 0.8800	OVERALL HEIGHT( PT IMPACT)	H6 = 2.1100
H. DIST. COG-LEAD PT INTER.	L6 = -0.0500	PROTECTIVE STRUCT. WIDTH	B6 = 0.7000
HEIGHT OF THE ENG. B.	H7 = 1.3700	WIDTH OF THE ENG. B.	B7 = 0.8000
H. DIST. COG-FRT COR. ENG. B.	L7 = 1.6390	HEIGHT FRT AXLE PIVOT PT	H0 = 0.4450
REAR TRACK WIDTH	S = 1.1150	REAR TYRE WIDTH	B0 = 0.1950
FRT AXLE SWING ANGLE	D0 = 0.1570	TRACTOR MASSM <sub>c</sub> = 1800.000	
MOMENT OF INERTIA	Q = 250.0000		

VELOCITY O0 = 3.840 rad/s  
VELOCITY O2 = 0.268 rad/s  
VELOCITY O4 = 0.672 rad/s  
VELOCITY O6 = 0.000 rad/s  
VELOCITY O8 = 0.000 rad/s

VELOCITY O1 = 0.281 rad/s  
VELOCITY O3 = 1.586 rad/s  
VELOCITY O5 = 0.000 rad/s  
VELOCITY O7 = 0.000 rad/s  
VELOCITY O9 = 0.000 rad/s

VELOCITY O0 = 3.840 rad/s  
VELOCITY O2 = 0.268 rad/s  
VELOCITY O4 = 0.867 rad/s  
VELOCITY O6 = 1.218 rad/s  
VELOCITY O8 = 0.898 rad/s

VELOCITY O1 = 0.281 rad/s  
VELOCITY O3 = 1.586 rad/s  
VELOCITY O5 = 0.755 rad/s  
VELOCITY O7 = 0.969 rad/s  
VELOCITY O9 = 0.000 rad/s

**THE ROLLING STOPS**

Location:      Date:      Engineer:

Example 6.2

**The rolling stops**

TEST NR:

FRONT MOUNTED-OVER PROTECTIVE STRUCTURE  
OF THE NARROW TRACTOR:

CHARACTERISTIC UNITS:

LINEAR (m): MASS (kg):

MOMENT OF INERTIA (kgm<sup>2</sup>): ANGLE (radian)

HEIGHT OF THE COG	H1 = 0.7180	H. DIST. COG-REAR AXLE	L3 = 0.8000
H. DIST. COG - FRONT AXLE	L2 = 1.1590	HEIGHT OF THE REAR TYRES	D3 = 1.5200
HEIGHT OF THE FRT TYRES	D2 = 0.7020	OVERALL HEIGHT( PT IMPACT)	H6 = 2.0040
H. DIST. COG-LEAD PT INTER.	L6 = -0.2000	PROTECTIVE STRUCT. WIDTH	B6 = 0.6400
HEIGHT OF THE ENG. B.	H7 = 1.2120	WIDTH OF THE ENG. B.	B7 = 0.3600
H. DIST. COG-FRT COR. ENG. B.	L7 = 1.6390	HEIGHT FRT AXLE PIVOT PT	H0 = 0.4400
REAR TRACK WIDTH	S = 0.9000	REAR TYRE WIDTH	B0 = 0.3150
FRT AXLE SWING ANGLE	D0 = 0.1740	TRACTOR MASSM <sub>c</sub> = 1780.000	
MOMENT OF INERTIA	Q = 279.8960		

VELOCITY O0 = 3.884 rad/s  
VELOCITY O2 = 0.098 rad/s  
VELOCITY O4 = 0.000 rad/s  
VELOCITY O6 = 0.000 rad/s  
VELOCITY O8 = 0.000 rad/s

VELOCITY O1 = 0.107 rad/s  
VELOCITY O3 = 0.000 rad/s  
VELOCITY O5 = 0.000 rad/s  
VELOCITY O7 = 0.000 rad/s  
VELOCITY O9 = 0.000 rad/s

VELOCITY O0 = 3.884 rad/s  
VELOCITY O2 = 0.098 rad/s  
VELOCITY O4 = 0.000 rad/s  
VELOCITY O6 = 0.000 rad/s  
VELOCITY O8 = 0.000 rad/s

VELOCITY O1 = 0.107 rad/s  
VELOCITY O3 = 0.000 rad/s  
VELOCITY O5 = 0.000 rad/s  
VELOCITY O7 = 0.000 rad/s  
VELOCITY O9 = 0.000 rad/s

**THE ROLLING STOPS**

Location:      Date:      Engineer:

Example 6.3

**The rolling stops**

TEST NR:

FRONT MOUNTED-OVER PROTECTIVE STRUCTURE  
OF THE NARROW TRACTOR:

CHARACTERISTIC UNITS:

LINEAR (m): MASS (kg):

MOMENT OF INERTIA (kgm<sup>2</sup>): ANGLE (radian)

HEIGHT OF THE COG	H1 = 0.7180	H. DIST. COG-REAR AXLE	L3 = 0.8110
H. DIST. COG - FRONT AXLE	L2 = 1.1590	HEIGHT OF THE REAR TYRES	D3 = 1.2170
HEIGHT OF THE FRT TYRES	D2 = 0.7020	OVERALL HEIGHT( PT IMPACT)	H6 = 2.1900
H. DIST. COG-LEAD PT INTER.	L6 = -0.3790	PROTECTIVE STRUCT. WIDTH	B6 = 0.6400
HEIGHT OF THE ENG. B.	H7 = 1.2120	WIDTH OF THE ENG. B.	B7 = 0.3600
H. DIST. COG-FRT COR. ENG. B.	L7 = 1.6390	HEIGHT FRT AXLE PIVOT PT	H0 = 0.4400
REAR TRACK WIDTH	S = 0.9000	REAR TYRE WIDTH	B0 = 0.3150
FRT AXLE SWING ANGLE	D0 = 0.1740	TRACTOR MASSM <sub>c</sub> = 1780.000	
MOMENT OF INERTIA	Q = 279.8960		

VELOCITY O0 = 3.884 rad/s  
VELOCITY O2 = 1.488 rad/s  
VELOCITY O4 = 0.405 rad/s  
VELOCITY O6 = 0.000 rad/s  
VELOCITY O8 = 0.000 rad/s

VELOCITY O1 = 1.540 rad/s  
VELOCITY O3 = 2.162 rad/s  
VELOCITY O5 = 0.000 rad/s  
VELOCITY O7 = 0.000 rad/s  
VELOCITY O9 = 0.000 rad/s

VELOCITY O0 = 3.884 rad/s  
VELOCITY O2 = 1.488 rad/s  
VELOCITY O4 = 0.414 rad/s  
VELOCITY O6 = 0.000 rad/s  
VELOCITY O8 = 0.000 rad/s

VELOCITY O1 = 1.540 rad/s  
VELOCITY O3 = 2.162 rad/s  
VELOCITY O5 = 0.289 rad/s  
VELOCITY O7 = 0.000 rad/s  
VELOCITY O9 = 0.000 rad/s

**THE ROLLING STOPS**

Location:      Date:      Engineer:

Example 6.4

**The rolling stops**

TEST NR:

FRONT MOUNTED-OVER PROTECTIVE STRUCTURE

OF THE NARROW TRACTOR:

CHARACTERISTIC UNITS:

LINEAR (m): MASS (kg):

MOMENT OF INERTIA (kgm<sup>2</sup>): ANGLE (radian)

HEIGHT OF THE COG	H1 = 0.7660	H. DIST. COG-REAR AXLE	L3 = 0.7970
H. DIST. COG - FRONT AXLE	L2 = 1.1490	HEIGHT OF THE REAR TYRES	D3 = 1.4800
HEIGHT OF THE FRT TYRES	D2 = 0.8800	OVERALL HEIGHT( PT IMPACT)	H6 = 2.1100
H. DIST. COG-LEAD PT INTER.	L6 = -0.2000	PROTECTIVE STRUCT. WIDTH	B6 = 0.7000
HEIGHT OF THE ENG. B.	H7 = 1.3700	WIDTH OF THE ENG. B.	B7 = 0.8000
H. DIST. COG-FRT COR. ENG. B.	L7 = 1.6390	HEIGHT FRT AXLE PIVOT PT	H0 = 0.4450
REAR TRACK WIDTH	S = 1.1150	REAR TYRE WIDTH	B0 = 0.9100
FRT AXLE SWING ANGLE	D0 = 0.1570	TRACTOR MASSM <sub>c</sub> = 1800.000	
MOMENT OF INERTIA	Q = 250.0000		

VELOCITY O0 = 2.735 rad/s  
VELOCITY O2 = 1.212 rad/s  
VELOCITY O4 = 1.337 rad/s  
VELOCITY O6 = 0.000 rad/s  
VELOCITY O8 = 0.000 rad/s

VELOCITY O1 = 1.271 rad/s  
VELOCITY O3 = 2.810 rad/s  
VELOCITY O5 = 0.000 rad/s  
VELOCITY O7 = 0.000 rad/s  
VELOCITY O9 = 0.000 rad/s

THE TILTING CONTINUES

Location:      Date:      Engineer:

Example 6.5

**The tilting continues**

TEST NR:

FRONT MOUNTED-OVER PROTECTIVE STRUCTURE  
OF THE NARROW TRACTOR:

CHARACTERISTIC UNITS:

LINEAR (m): MASS (kg):

MOMENT OF INERTIA (kgm<sup>2</sup>): ANGLE (radian)

HEIGHT OF THE COG	H1 = 0.7653	H. DIST. COG-REAR AXLE	L3 = 0.7970
H. DIST. COG - FRONT AXLE	L2 = 1.1490	HEIGHT OF THE REAR TYRES	D3 = 1.2930
HEIGHT OF THE FRT TYRES	D2 = 0.8800	OVERALL HEIGHT( PT IMPACT)	H6 = 1.9600
H. DIST. COG-LEAD PT INTER.	L6 = -0.4000	PROTECTIVE STRUCT. WIDTH	B6 = 0.7000
HEIGHT OF THE ENG. B.	H7 = 1.3700	WIDTH OF THE ENG. B.	B7 = 0.8750
H. DIST. COG-FRT COR. ENG. B.	L7 = 1.6390	HEIGHT FRT AXLE PIVOT PT	H0 = 0.4450
REAR TRACK WIDTH	S = 1.1150	REAR TYRE WIDTH	B0 = 0.1950
FRT AXLE SWING ANGLE	D0 = 0.1570	TRACTOR MASSM <sub>c</sub> = 1800.000	
MOMENT OF INERTIA	Q = 275.0000		

VELOCITY O0 = 3.815 rad/s  
 VELOCITY O2 = 1.105 rad/s  
 VELOCITY O4 = 0.786 rad/s  
 VELOCITY O6 = 0.000 rad/s  
 VELOCITY O8 = 0.000 rad/s

VELOCITY O1 = 1.130 rad/s  
 VELOCITY O3 = 2.196 rad/s  
 VELOCITY O5 = 0.000 rad/s  
 VELOCITY O7 = 0.000 rad/s  
 VELOCITY O9 = 0.000 rad/s

VELOCITY O0 = 3.815 rad/s  
 VELOCITY O2 = 1.105 rad/s  
 VELOCITY O4 = 0.980 rad/s  
 VELOCITY O6 = 0.000 rad/s  
 VELOCITY O8 = 0.000 rad/s

VELOCITY O1 = 1.130 rad/s  
 VELOCITY O3 = 2.196 rad/s  
 VELOCITY O5 = 0.675 rad/s  
 VELOCITY O7 = 0.000 rad/s  
 VELOCITY O9 = 0.548 rad/s

**THE TILTING CONTINUES**

Location:            Date:            Engineer:

Example 6.6

**The tilting continues**

TEST NR:

FRONT MOUNTED-OVER PROTECTIVE STRUCTURE  
OF THE NARROW TRACTOR:

CHARACTERISTIC UNITS:

LINEAR (m): MASS (kg):

MOMENT OF INERTIA (kgm<sup>2</sup>): ANGLE (radian)

HEIGHT OF THE COG	H1 = 0.7620	H. DIST. COG-REAR AXLE	L3 = 0.7970
H. DIST. COG - FRONT AXLE	L2 = 1.1490	HEIGHT OF THE REAR TYRES	D3 = 1.5500
HEIGHT OF THE FRT TYRES	D2 = 0.8800	OVERALL HEIGHT( PT IMPACT)	H6 = 2.1000
H. DIST. COG-LEAD PT INTER.	L6 = -0.4780	PROTECTIVE STRUCT. WIDTH	B6 = 0.7780
HEIGHT OF THE ENG. B.	H7 = 1.5500	WIDTH OF THE ENG. B.	B7 = 0.9500
H. DIST. COG-FRT COR. ENG. B.	L7 = 1.6390	HEIGHT FRT AXLE PIVOT PT	H0 = 0.4450
REAR TRACK WIDTH	S = 1.1150	REAR TYRE WIDTH	B0 = 0.1950
FRT AXLE SWING ANGLE	D0 = 0.1570	TRACTOR MASSM <sub>c</sub> = 1800.000	
MOMENT OF INERTIA	Q = 200.0000		

**THE ENGINE BONNET TOUCHES THE GROUND BEFORE THE ROPS  
METHOD OF CALCULATION NOT FEASIBLE**

Location:      Date:      Engineer:

Example 6.7

**Method of calculation not feasible**



TEST NR:

FRONT MOUNTED-OVER PROTECTIVE STRUCTURE  
OF THE NARROW TRACTOR:

CHARACTERISTIC UNITS:

LINEAR (m): MASS (kg):

MOMENT OF INERTIA (kgm<sup>2</sup>): ANGLE (radian)

HEIGHT OF THE COG	H1 = 0.7180	H. DIST. COG-REAR AXLE	L3 = 0.8110
H. DIST. COG - FRONT AXLE	L2 = 1.1590	HEIGHT OF THE REAR TYRES	D3 = 1.2170
HEIGHT OF THE FRT TYRES	D2 = 0.7020	OVERALL HEIGHT( PT IMPACT)	H6 = 2.0040
H. DIST. COG-LEAD PT INTER.	L6 = -0.3790	PROTECTIVE STRUCT. WIDTH	B6 = 0.6400
HEIGHT OF THE ENG. B.	H7 = 1.2120	WIDTH OF THE ENG. B.	B7 = 0.3600
H. DIST. COG-FRT COR. ENG. B.	L7 = 1.6390	HEIGHT FRT AXLE PIVOT PT	H0 = 0.4400
REAR TRACK WIDTH	S = 0.9000	REAR TYRE WIDTH	B0 = 0.3150
FRT AXLE SWING ANGLE	D0 = 0.1740	TRACTOR MASSM <sub>c</sub> = 1780.000	
MOMENT OF INERTIA	Q = 279.8960		

VELOCITY O0 = 3.884 rad/s  
VELOCITY O2 = 1.488 rad/s  
VELOCITY O4 = 0.581 rad/s  
VELOCITY O6 = 0.000 rad/s  
VELOCITY O8 = 0.000 rad/s

VELOCITY O1 = 1.540 rad/s  
VELOCITY O3 = 2.313 rad/s  
VELOCITY O5 = 0.000 rad/s  
VELOCITY O7 = 0.000 rad/s  
VELOCITY O9 = 0.000 rad/s

VELOCITY O0 = 3.884 rad/s  
VELOCITY O2 = 1.488 rad/s  
VELOCITY O4 = 0.633 rad/s  
VELOCITY O6 = 0.000 rad/s  
VELOCITY O8 = 0.000 rad/s

VELOCITY O1 = 1.540 rad/s  
VELOCITY O3 = 2.313 rad/s  
VELOCITY O5 = 0.373 rad/s  
VELOCITY O7 = 0.000 rad/s  
VELOCITY O9 = 0.000 rad/s

**THE ROLLING STOPS**

Location:      Date:      Engineer:

Example 6.8

**The rolling stops**

TEST NR:

FRONT MOUNTED-OVER PROTECTIVE STRUCTURE  
OF THE NARROW TRACTOR:

CHARACTERISTIC UNITS:

LINEAR (m): MASS (kg):

MOMENT OF INERTIA (kgm<sup>2</sup>): ANGLE (radian)

HEIGHT OF THE COG	H1 = 0.7620	H. DIST. COG-REAR AXLE	L3 = 0.7970
H. DIST. COG - FRONT AXLE	L2 = 1.1490	HEIGHT OF THE REAR TYRES	D3 = 1.2930
HEIGHT OF THE FRT TYRES	D2 = 0.8800	OVERALL HEIGHT( PT IMPACT)	H6 = 1.9670
H. DIST. COG-LEAD PT INTER.	L6 = -0.3000	PROTECTIVE STRUCT. WIDTH	B6 = 0.7700
HEIGHT OF THE ENG. B.	H7 = 1.3500	WIDTH OF THE ENG. B.	B7 = 0.9500
H. DIST. COG-FRT COR. ENG. B.	L7 = 1.6390	HEIGHT FRT AXLE PIVOT PT	H0 = 0.4450
REAR TRACK WIDTH	S = 1.1150	REAR TYRE WIDTH	B0 = 0.1950
FRT AXLE SWING ANGLE	D0 = 0.1570	TRACTOR MASSM <sub>c</sub> = 1800.000	
MOMENT OF INERTIA	Q = 300.0000		

VELOCITY O0 = 3.790 rad/s  
VELOCITY O2 = 1.133 rad/s  
VELOCITY O4 = 0.801 rad/s  
VELOCITY O6 = 0.000 rad/s  
VELOCITY O8 = 0.000 rad/s

VELOCITY O1 = 1.159 rad/s  
VELOCITY O3 = 2.118 rad/s  
VELOCITY O5 = 0.000 rad/s  
VELOCITY O7 = 0.000 rad/s  
VELOCITY O9 = 0.000 rad/s

VELOCITY O0 = 3.790 rad/s  
VELOCITY O2 = 1.133 rad/s  
VELOCITY O4 = 0.856 rad/s  
VELOCITY O6 = 0.000 rad/s  
VELOCITY O8 = 0.000 rad/s

VELOCITY O1 = 1.159 rad/s  
VELOCITY O3 = 2.118 rad/s  
VELOCITY O5 = 0.562 rad/s  
VELOCITY O7 = 0.000 rad/s  
VELOCITY O9 = 0.205 rad/s

THE TILTING CONTINUES

Location:      Date:      Engineer:

Example 6.9

The tilting continues

TEST NR:

FRONT MOUNTED-OVER PROTECTIVE STRUCTURE  
OF THE NARROW TRACTOR:

CHARACTERISTIC UNITS:

LINEAR (m): MASS (kg):

MOMENT OF INERTIA (kgm<sup>2</sup>): ANGLE (radian)

HEIGHT OF THE COG	H1 = 0.7653	H. DIST. COG-REAR AXLE	L3 = 0.7970
H. DIST. COG - FRONT AXLE	L2 = 1.1490	HEIGHT OF THE REAR TYRES	D3 = 1.3800
HEIGHT OF THE FRT TYRES	D2 = 0.8800	OVERALL HEIGHT( PT IMPACT)	H6 = 1.9600
H. DIST. COG-LEAD PT INTER.	L6 = -0.3000	PROTECTIVE STRUCT. WIDTH	B6 = 0.7000
HEIGHT OF THE ENG. B.	H7 = 1.3700	WIDTH OF THE ENG. B.	B7 = 0.8900
H. DIST. COG-FRT COR. ENG. B.	L7 = 1.6390	HEIGHT FRT AXLE PIVOT PT	H0 = 0.4450
REAR TRACK WIDTH	S = 1.1150	REAR TYRE WIDTH	B0 = 0.1950
FRT AXLE SWING ANGLE	D0 = 0.1570	TRACTOR MASSM <sub>c</sub> = 1800.000	
MOMENT OF INERTIA	Q = 275.0000		

VELOCITY O0 = 3.815 rad/s  
VELOCITY O2 = 0.724 rad/s  
VELOCITY O4 = 0.808 rad/s  
VELOCITY O6 = 0.000 rad/s  
VELOCITY O8 = 0.000 rad/s

VELOCITY O1 = 0.748 rad/s  
VELOCITY O3 = 1.956 rad/s  
VELOCITY O5 = 0.000 rad/s  
VELOCITY O7 = 0.000 rad/s  
VELOCITY O9 = 0.407 rad/s

THE TILTING CONTINUES

Location:      Date:      Engineer:

Example 6.10

**The tilting continues**

TEST NR:

FRONT MOUNTED-OVER PROTECTIVE STRUCTURE  
OF THE NARROW TRACTOR:

CHARACTERISTIC UNITS:

LINEAR (m): MASS (kg):

MOMENT OF INERTIA (kgm<sup>2</sup>): ANGLE (radian)

HEIGHT OF THE COG	H1 = 0.7653	H. DIST. COG-REAR AXLE	L3 = 0.7970
H. DIST. COG - FRONT AXLE	L2 = 1.1490	HEIGHT OF THE REAR TYRES	D3 = 1.4800
HEIGHT OF THE FRT TYRES	D2 = 0.9000	OVERALL HEIGHT( PT IMPACT)	H6 = 1.9600
H. DIST. COG-LEAD PT INTER.	L6 = -0.4000	PROTECTIVE STRUCT. WIDTH	B6 = 0.7000
HEIGHT OF THE ENG. B.	H7 = 1.3700	WIDTH OF THE ENG. B.	B7 = 0.8000
H. DIST. COG-FRT COR. ENG. B.	L7 = 1.6390	HEIGHT FRT AXLE PIVOT PT	H0 = 0.4450
REAR TRACK WIDTH	S = 1.1150	REAR TYRE WIDTH	B0 = 0.1950
FRT AXLE SWING ANGLE	D0 = 0.1570	TRACTOR MASSM <sub>c</sub> = 1800.000	
MOMENT OF INERTIA	Q = 250.0000		

VELOCITY O0 = 3.840  
VELOCITY O2 = 0.235  
VELOCITY O4 = 0.000  
VELOCITY O6 = 0.000  
VELOCITY O8 = 0.000

VELOCITY O1 = 0.246  
VELOCITY O3 = 0.000  
VELOCITY O5 = 0.000  
VELOCITY O7 = 0.000  
VELOCITY O9 = 0.000

VELOCITY O0 = 3.840  
VELOCITY O2 = 0.235  
VELOCITY O4 = 0.000  
VELOCITY O6 = 0.000  
VELOCITY O8 = 0.000

VELOCITY O1 = 0.246  
VELOCITY O3 = 0.000  
VELOCITY O5 = 0.000  
VELOCITY O7 = 0.000  
VELOCITY O9 = 0.000

**THE ROLLING STOPS**

Location:      Date:      Engineer:

Example 6.11

**The rolling stops**

Dimensions in mm

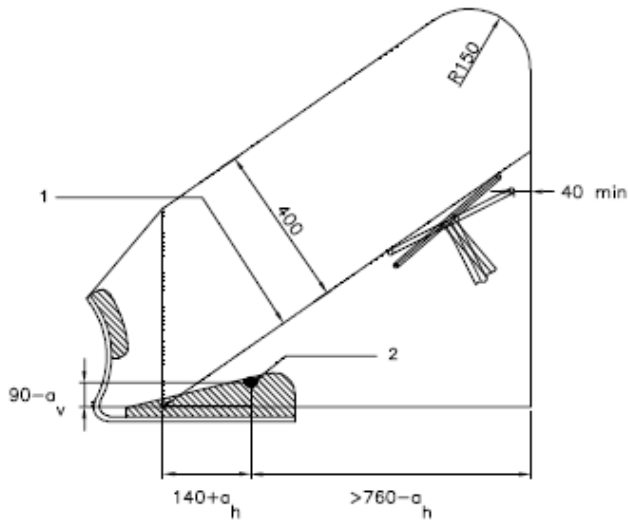

Figure 6.1.a  
Side view

Cross-section through the reference plane

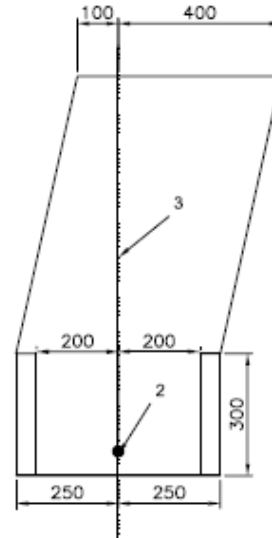

Figure 6.1.b  
Rear view

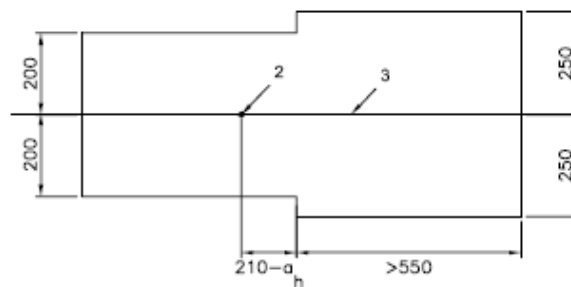

Figure 6.1.c  
View from above

- 1 – Reference line
- 2 – Seat index point
- 3 – Reference plane

Figure 6.1

Clearance zone

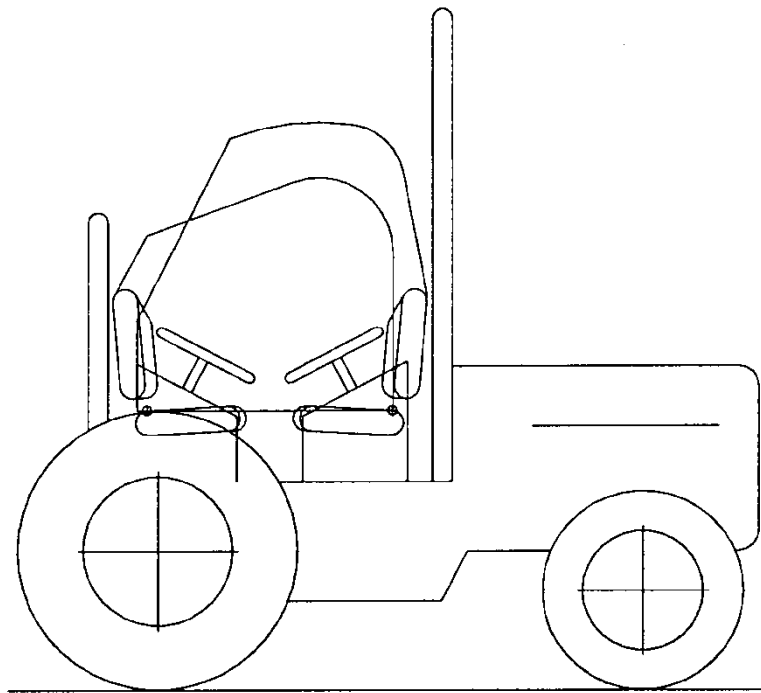
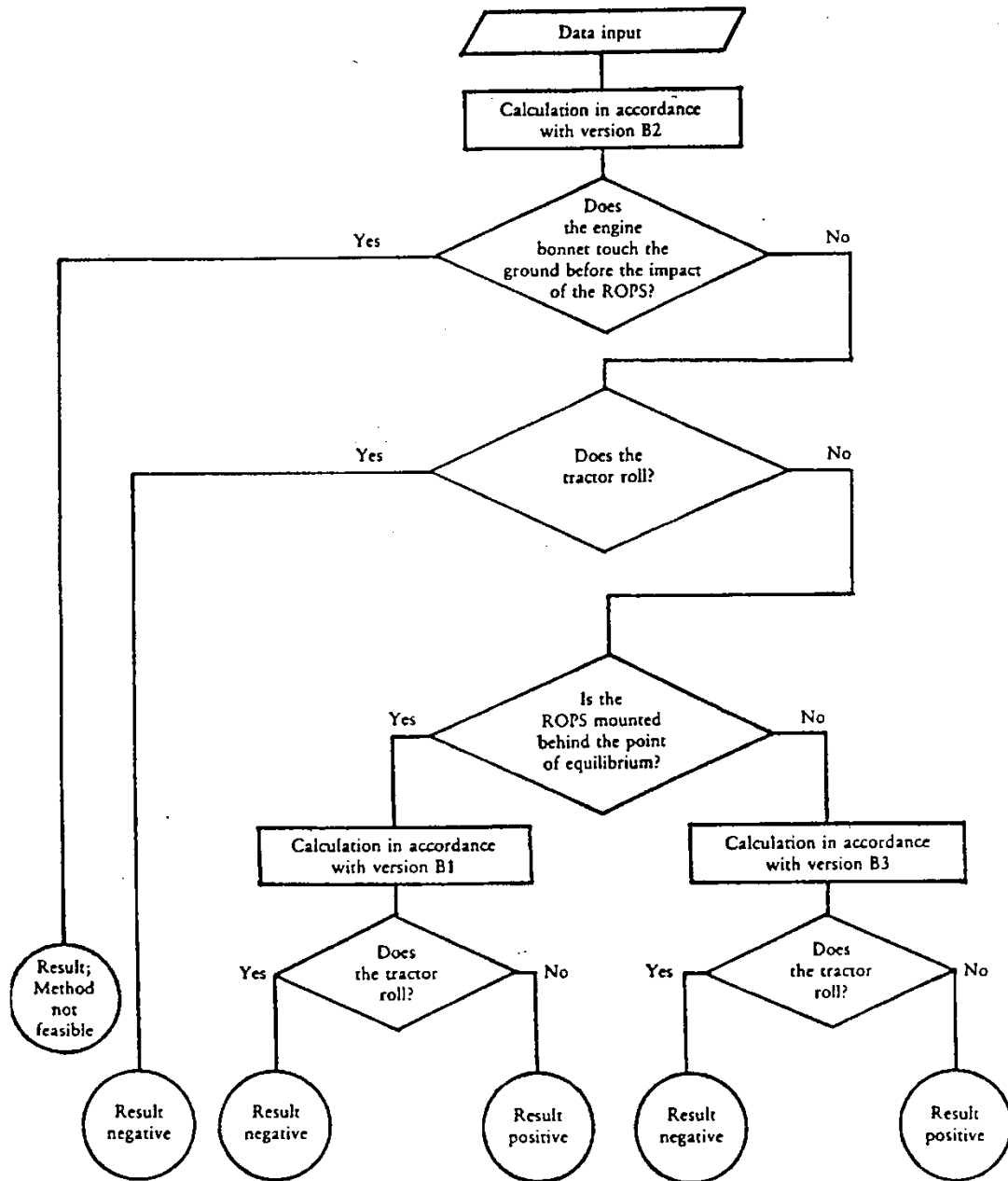

Figure 6.2

**Clearance zone for tractors with reversible seat and steering wheel**



Version B1: Point of impact of ROPS behind longitudinally unstable equilibrium point  
 Version B2: Point of impact of ROPS near longitudinally unstable equilibrium point  
 Version B3: Point of impact of ROPS in front of longitudinally unstable equilibrium point

Figure 6.3

**Flow diagram for determining the continuous roll-over behaviour of a laterally overturning tractor with a front mounted roll-over protective structure (ROPS)**

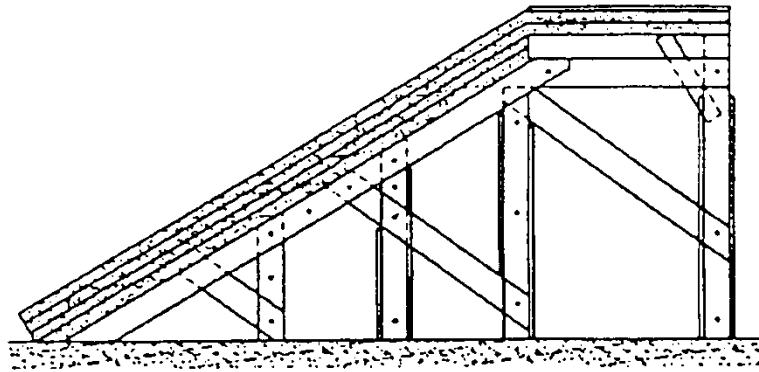
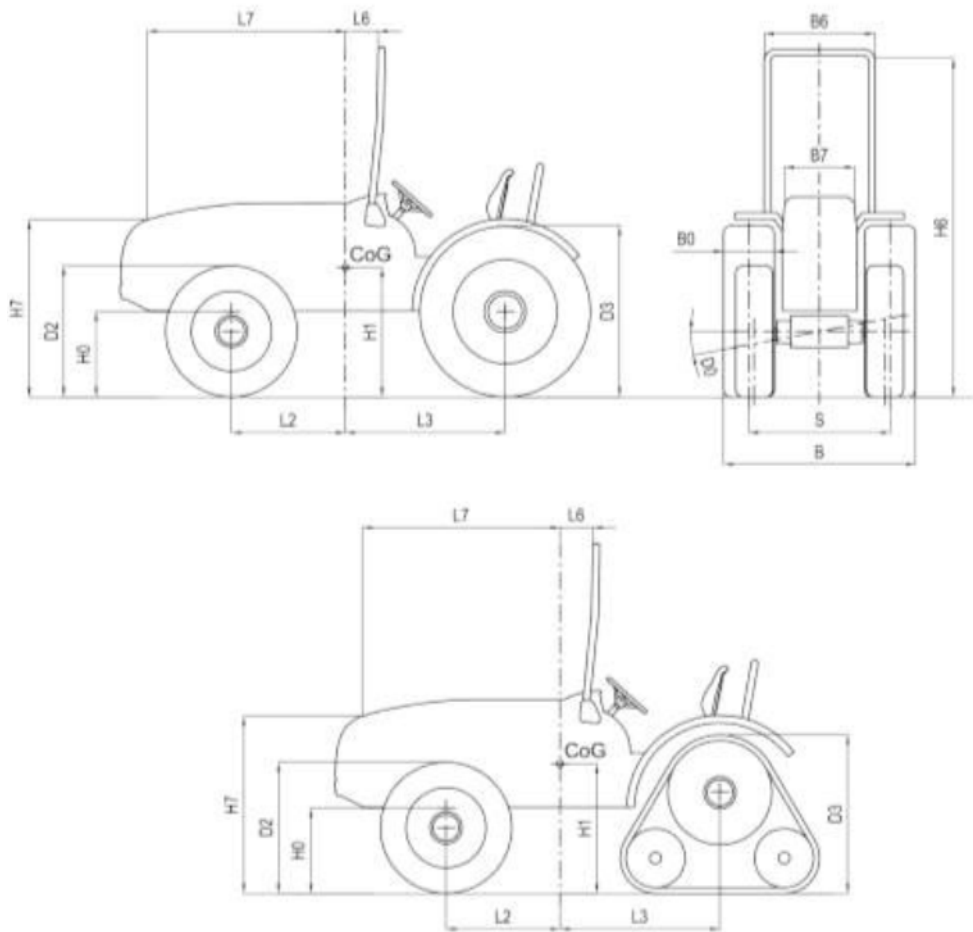

Figure 6.4

**Rig for testing anti-roll properties on 1/ 1.5 gradient**





Note: D2 and D3 should be measured under full axle load

Figure 6.5

**Data required for calculating the overturn of a tractor  
with triaxial rolling behaviour**

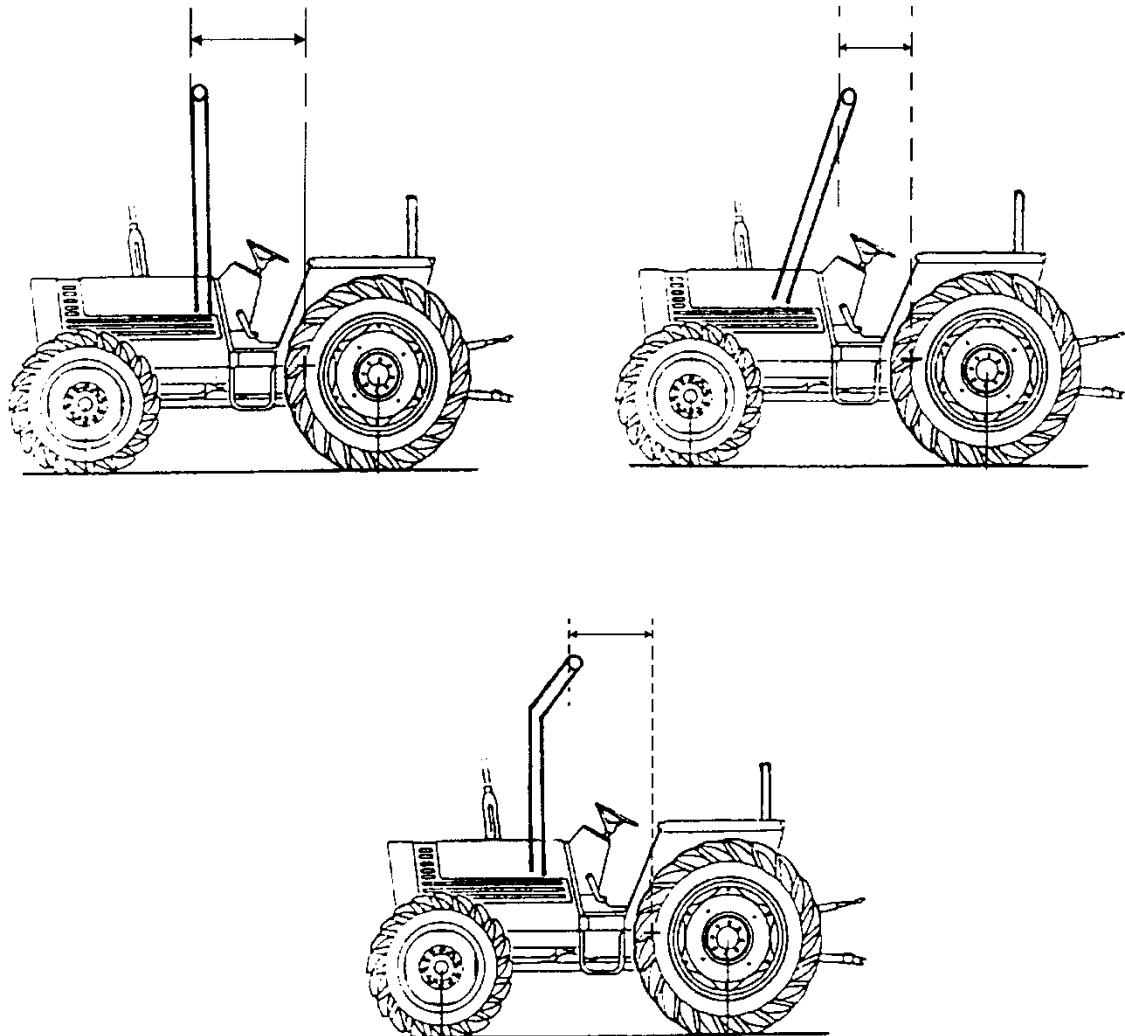

Figures 6.6.a, 6.6.b, 6.6.c

**Horizontal distance between the centre of gravity  
and the leading point of intersection of the protective structure (L6)**

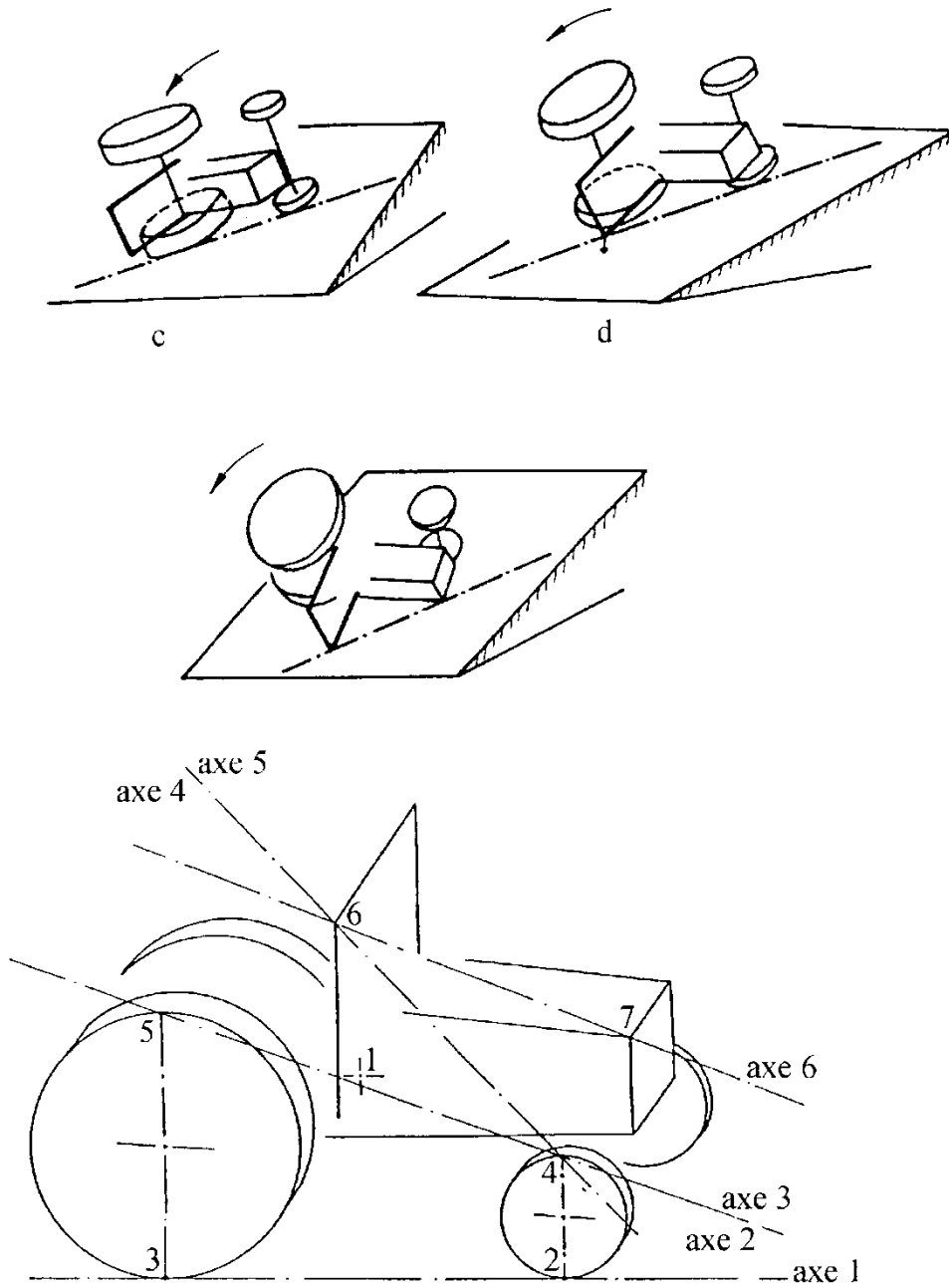

Figure 6.7

**Determination of points of impact  
for measurement of width of protective structure (B6)  
and height of engine bonnet (H7)**

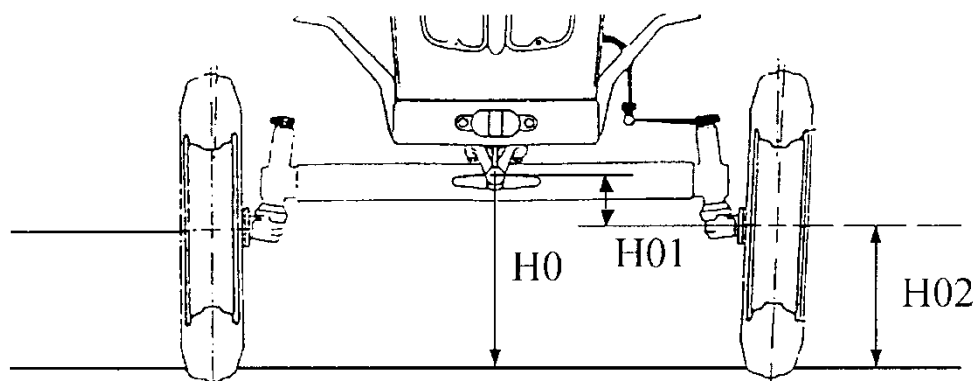

Figure 6.8

**Height of the front-axle pivot point ( $H_0$ )**

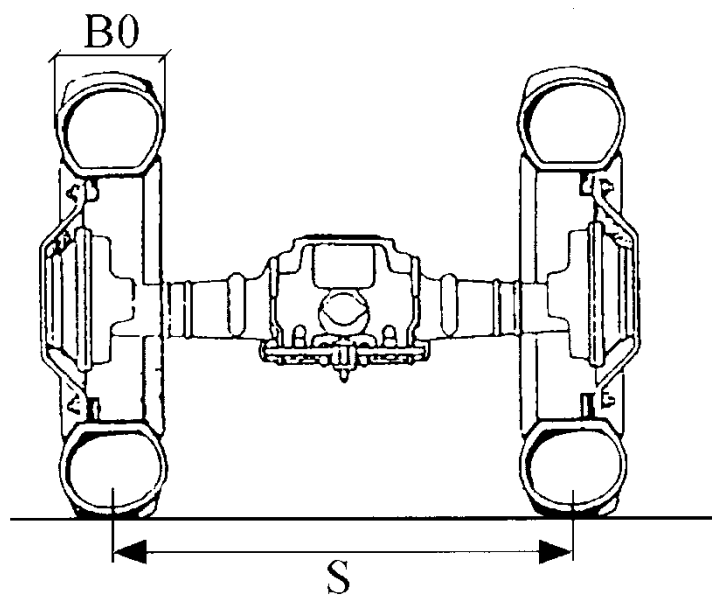

Figure 6.9

**Rear track width ( $S$ ) and Rear tyre width ( $B_0$ )**

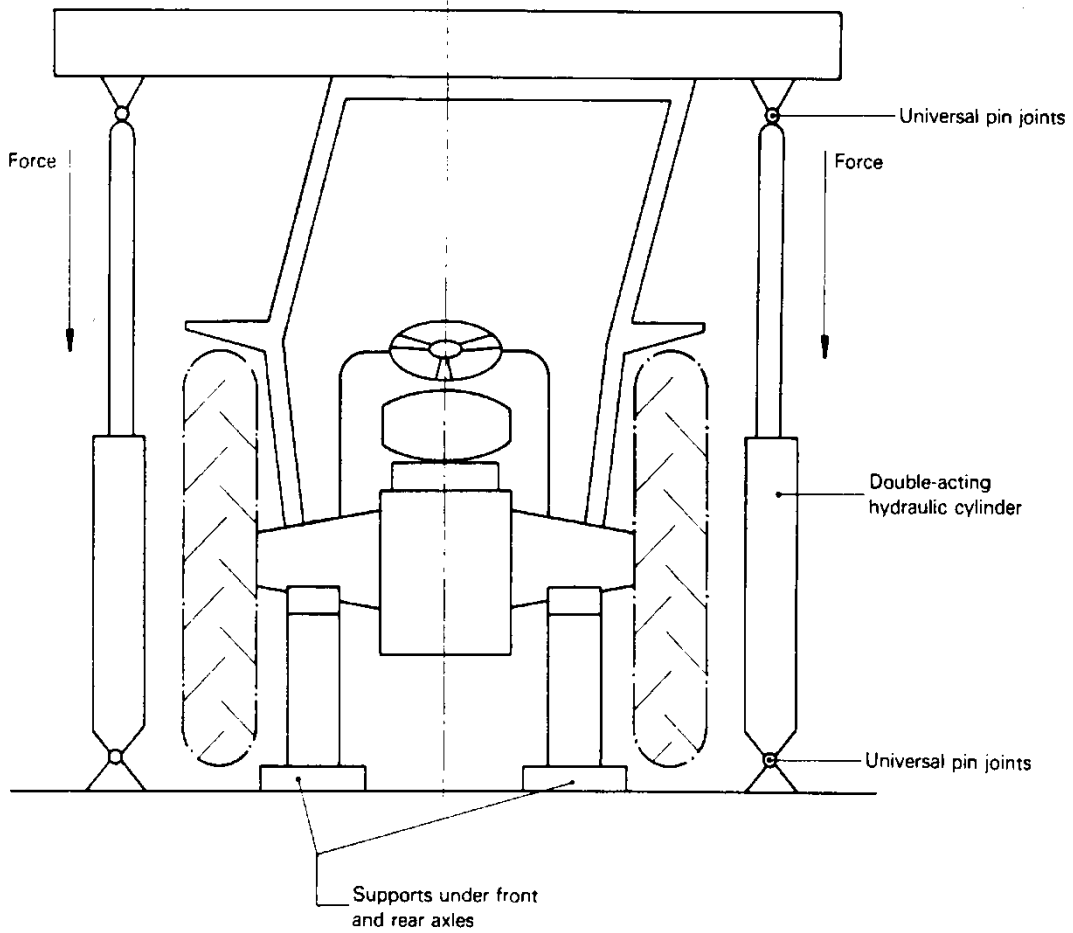
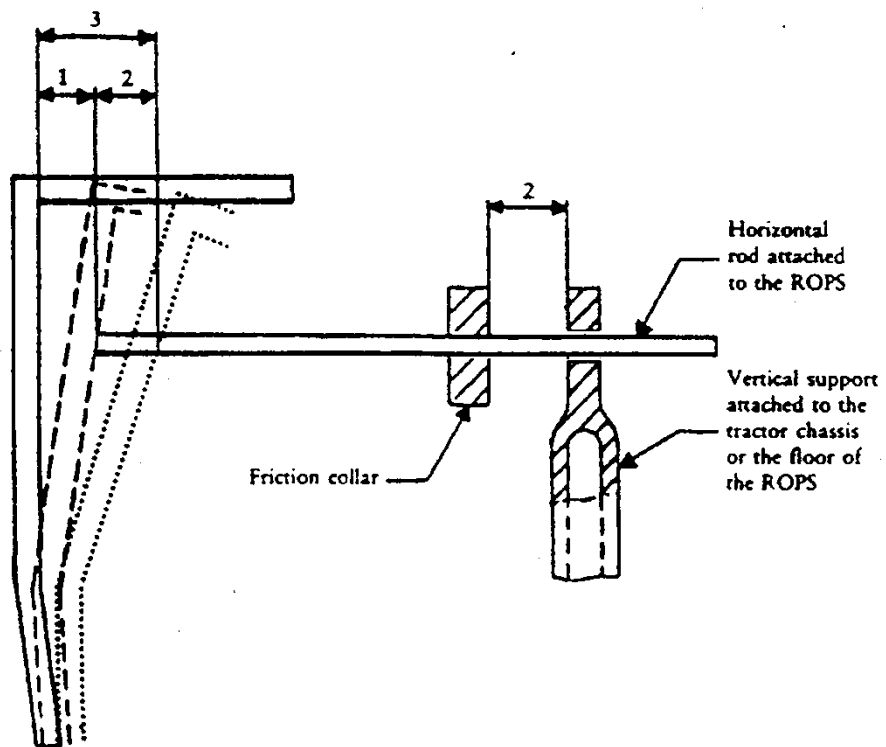

Figure 6.10

**Example of crushing rig of the tractor**



- 1 – Permanent deflection
- 2 – Elastic deflection
- 3 – Total deflection (permanent plus elastic)

Figure 6.11

**Example of apparatus for measuring elastic deflection**

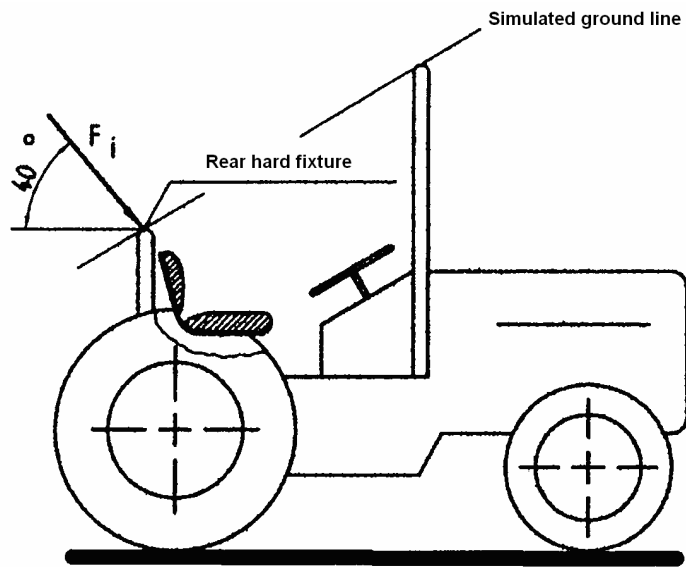

Figure 6.12

**Simulated ground line**

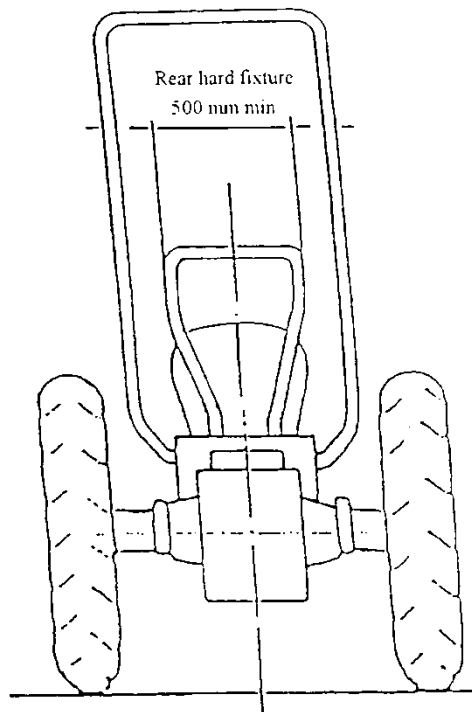
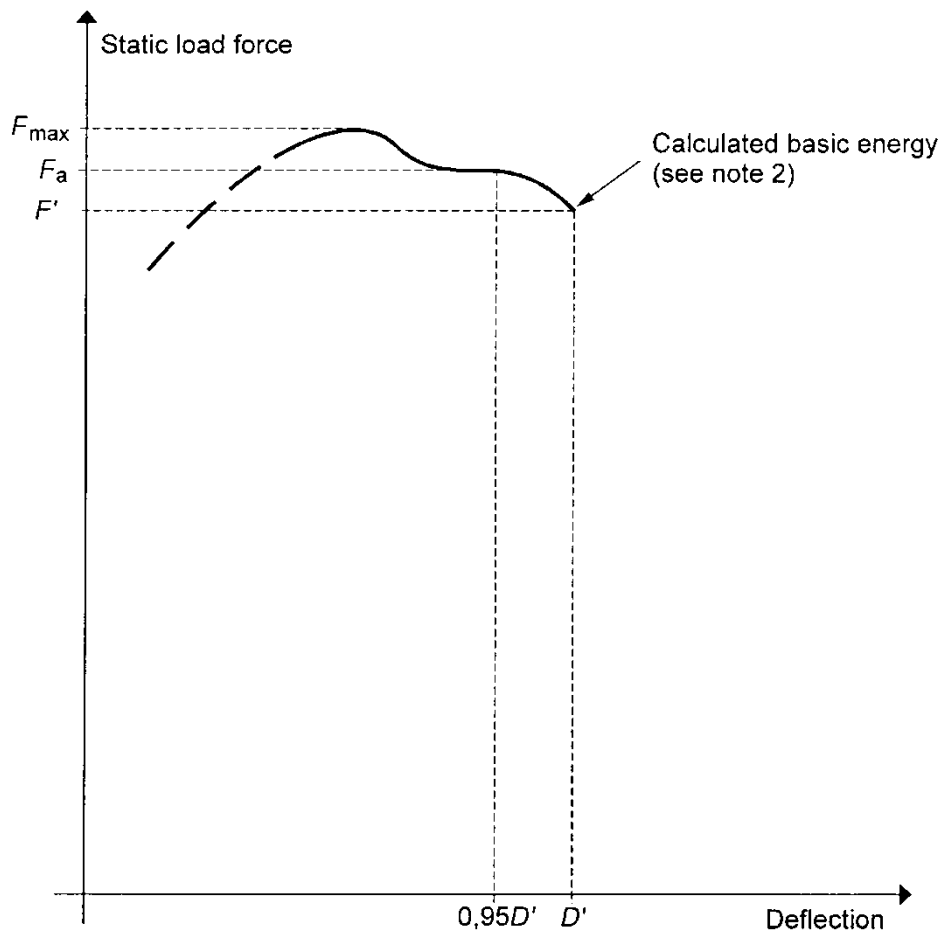

Figure 6.13

**Minimum width of the rear hard fixture**



Notes:

1. Locate  $F_a$  in relation to  $0,95 D'$
2. Overload test not necessary as  $F_a \leq 1,03 F'$

Figure 6.14

**Force / deflection curve**  
**Overload test not necessary**



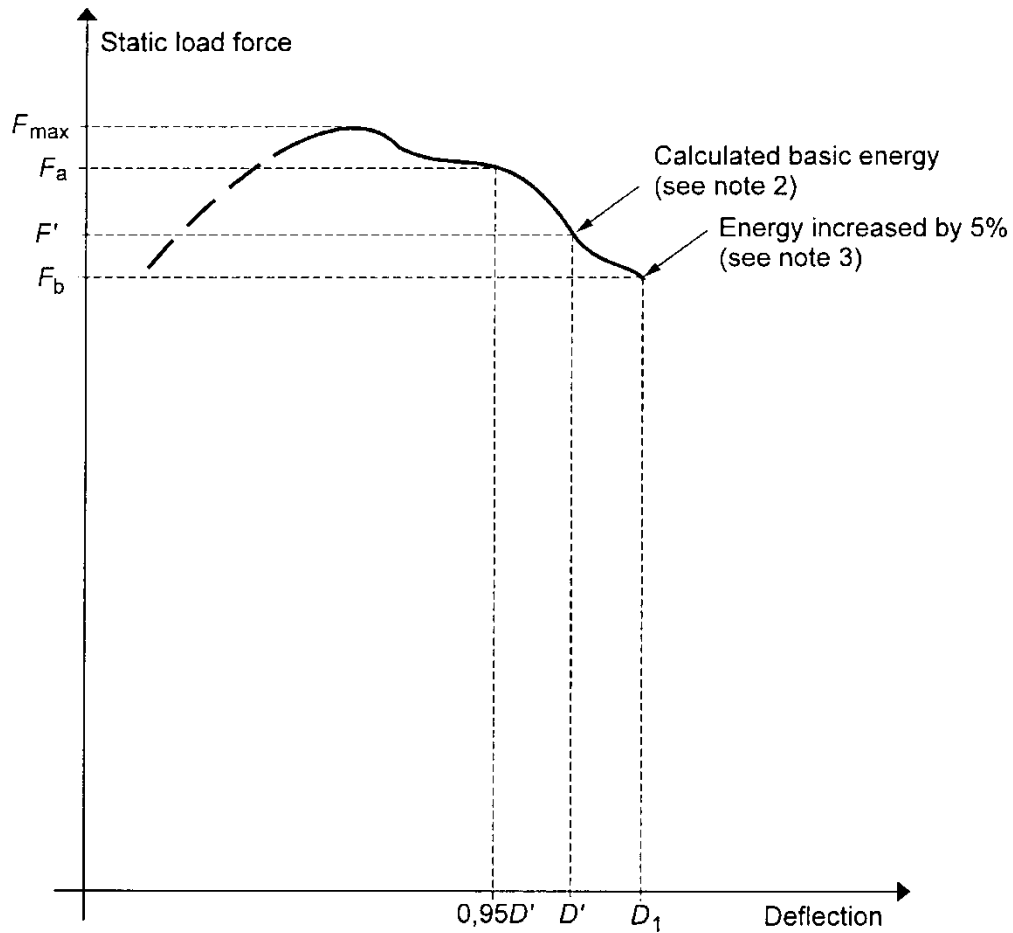

Notes:

1. Locate  $F_a$  in relation to  $0,95 D'$
2. Overload test necessary as  $F_a > 1,03 F'$
3. Overload test performance satisfactory as  $F_b > 0,97F'$  and  $F_b > 0,8F_{max}$ .

Figure 6.15

**Force / deflection curve  
Overload test necessary**

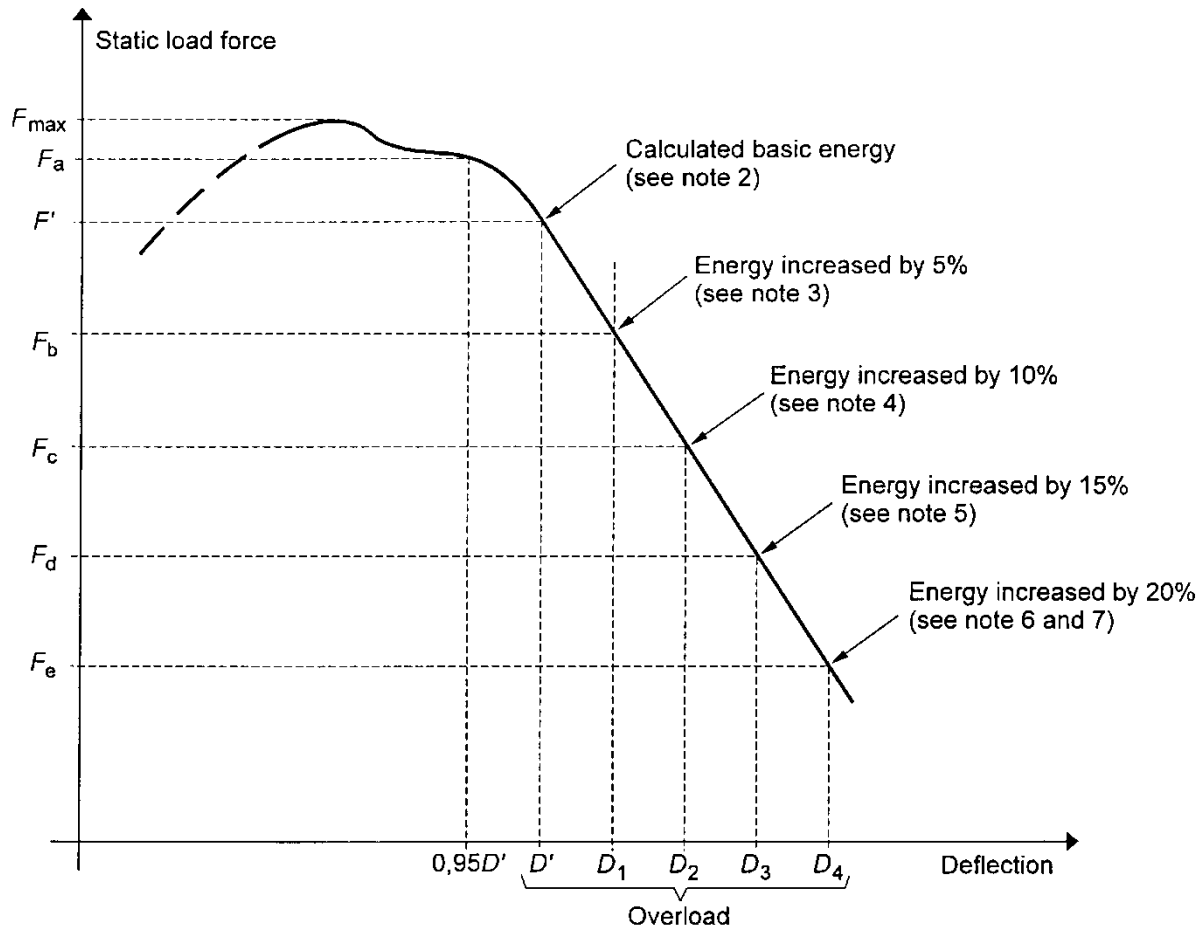

Notes:

1. Locate  $F_a$  in relation to  $0,95 D'$
2. Overload test necessary as  $F_a > 1,03 F'$
3.  $F_b < 0,97 F'$  therefore further overload necessary
4.  $F_c < 0,97 F_b$  therefore further overload necessary
5.  $F_d < 0,97 F_c$  therefore further overload necessary
6. Overload test performance satisfactory, if  $F_e > 0,8 F_{max}$
7. Failure at any stage when load drops below  $0,8 F_{max}$ .

Figure 6.16

**Force / deflection curve  
Overload test to be continued**

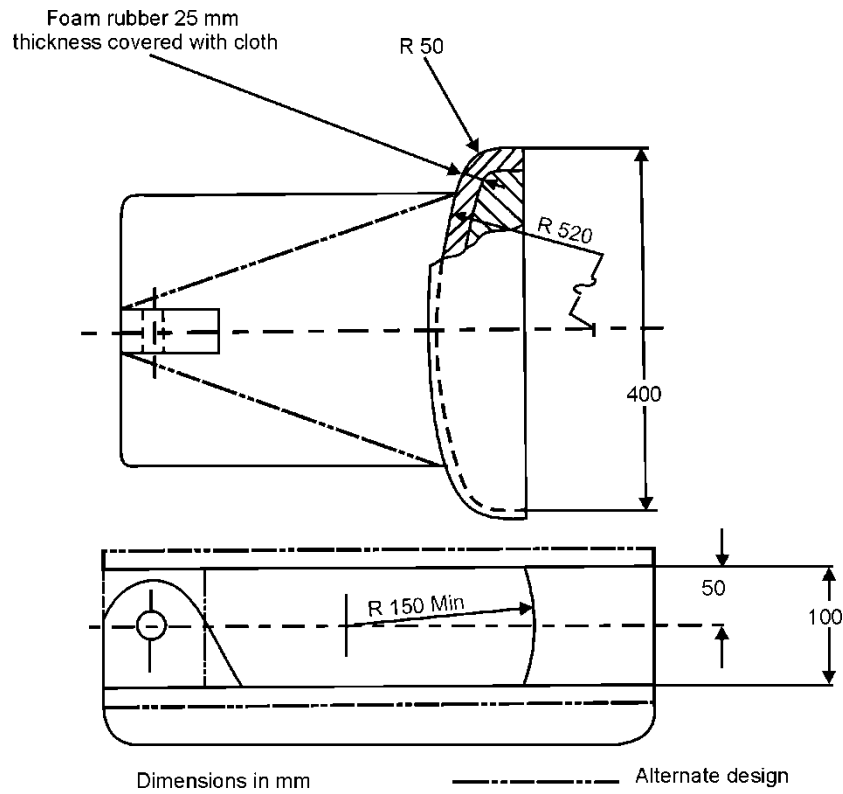

Figure 6.17

**The load application device**

Note: The dimensions not shown are optional to satisfy the test facility and do not influence the test results

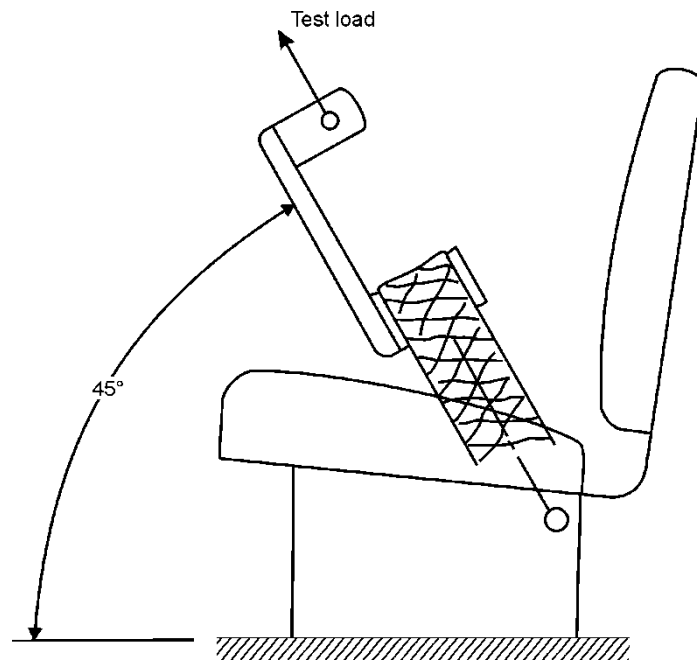

Figure 6.18

**Load application in the upward and forward direction**

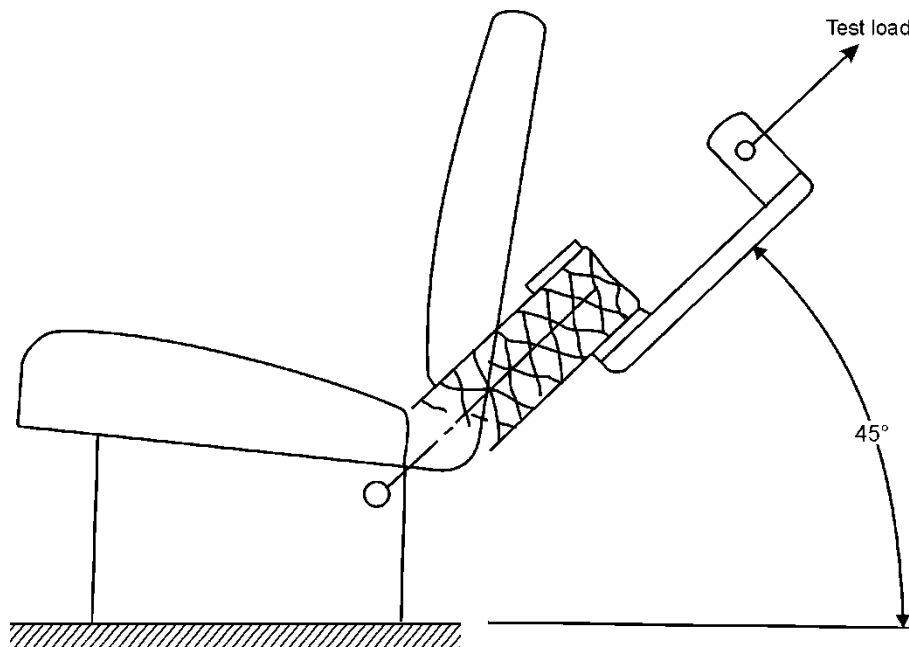

Figure 6.19

**Load application in the upward and rearward direction**

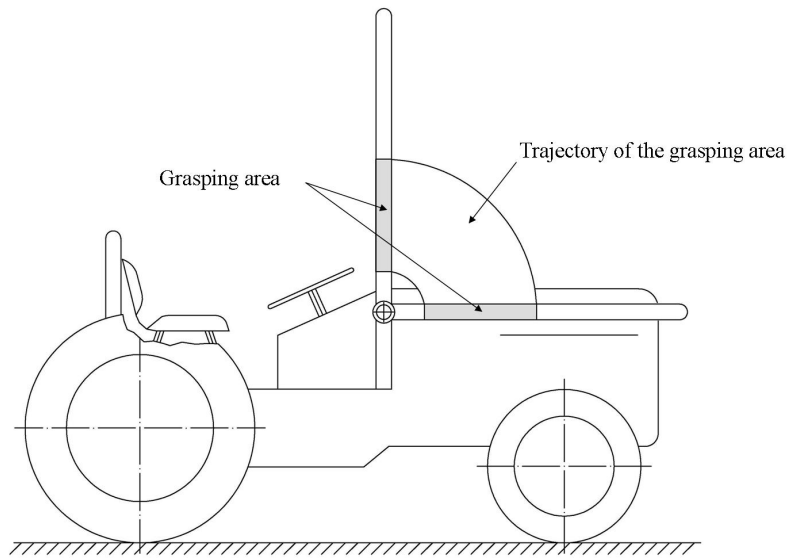

Figure 6.20

**Grasping area**

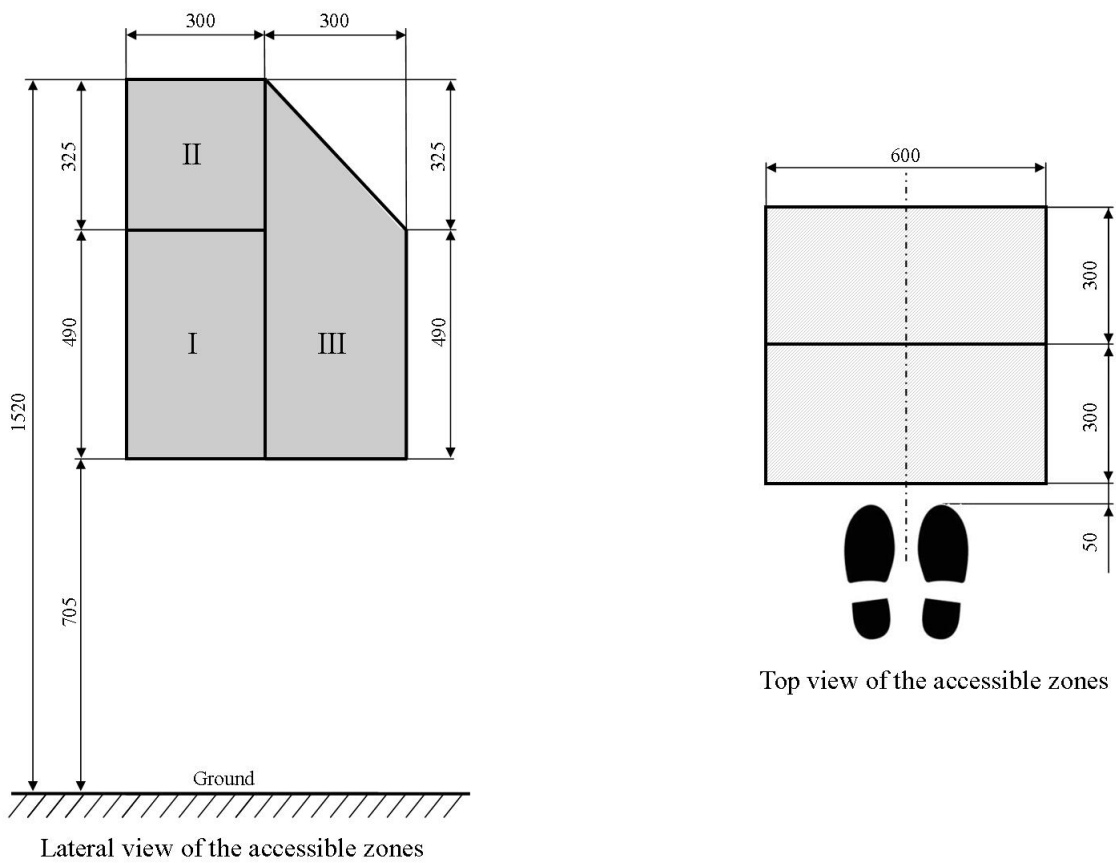

Figure 6.21  
**Accessible zones**  
**(Dimensions in mm)**

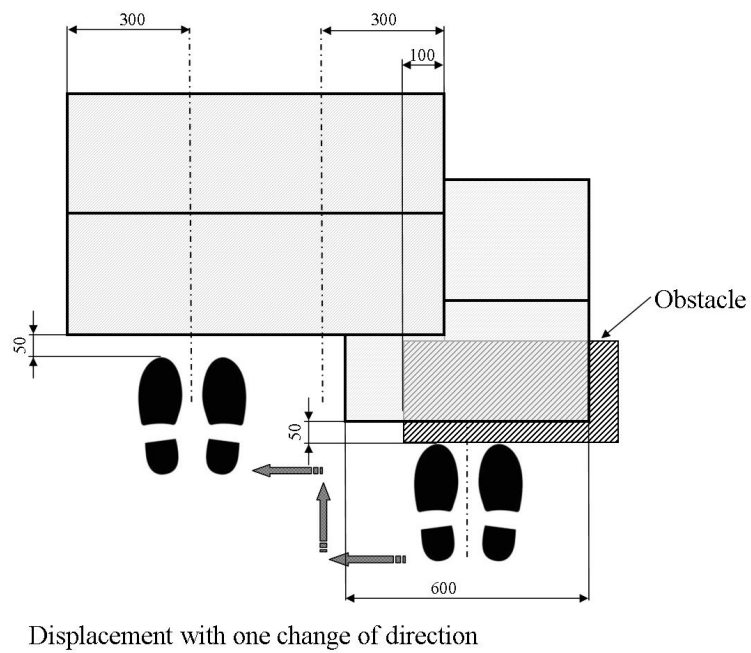
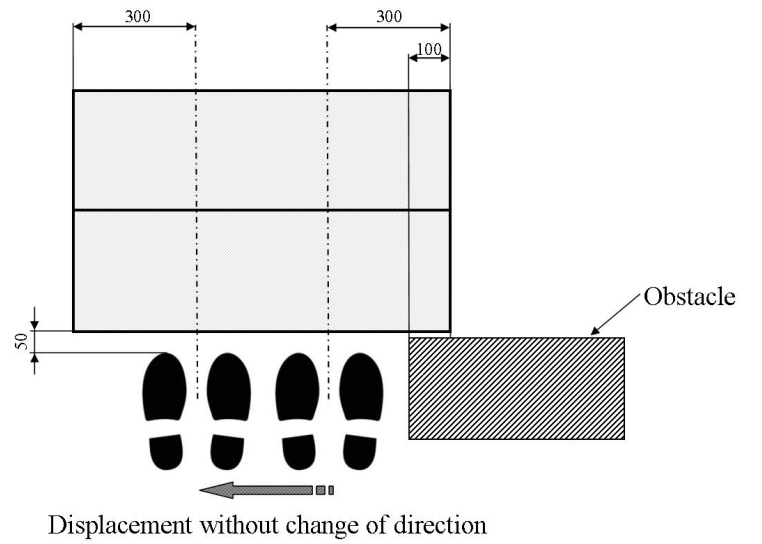

Figure 6.22

**Envelope of the accessible zones  
(Dimensions in mm)**

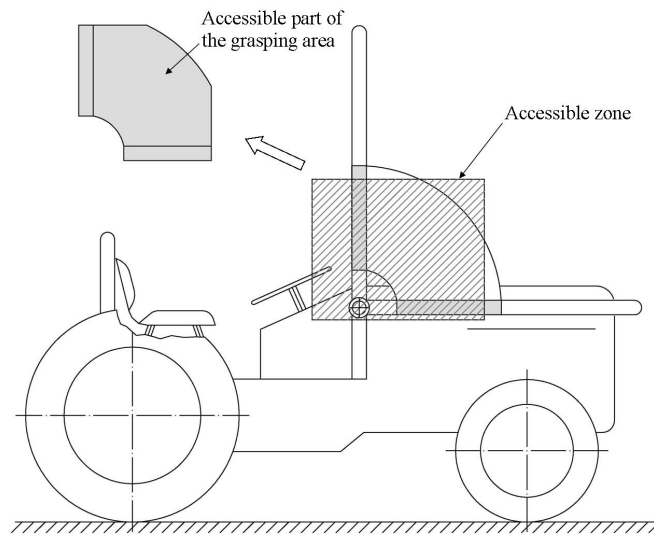

Figure 6.23

**Accessible part of the grasping area**

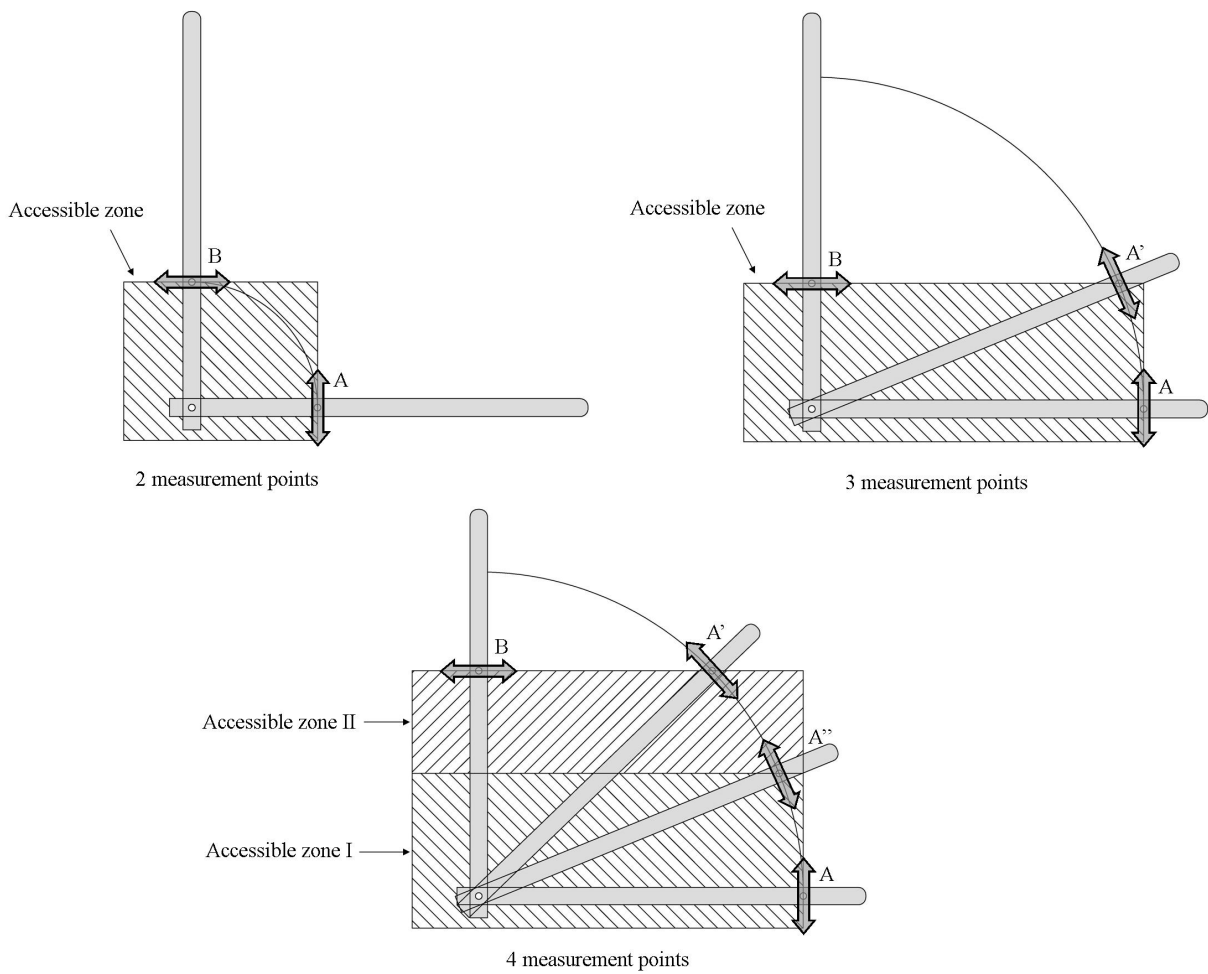

Figure 6.24

**Points where the force requirement shall be measured**

**SPECIMEN TEST REPORT**

**Note:** Units shown below, which appear in ISO 80000-1:2009/Cor.1:2011, shall be stated and followed by national units in parentheses, if necessary.

- Protective structure manufacturer’s name and address:
- Submitted for test by:
  
- Make of the protective structure:
- Model of the protective structure:
- Type of the protective structure: *Cab, Frame, Rear rollbar, Cab with integrated frame, etc.*
  
- Date, location of test and Code version:

**1. SPECIFICATIONS OF TEST TRACTOR**

**1.1 Identification of tractor to which the protective structure is fitted for the test**

- 1.1.1 - Make of the tractor: (\*)  
 - Model (trade name):  
 - Type: *2 WD or 4 WD; rubber or steel tracks (if applicable); articulated 4 WD or articulated 4 WD with twin (dual) wheels (if applicable)*  
 (\*) possibly different from tractor manufacturer's name

- 1.1.2 Numbers  
 - 1<sup>st</sup> Serial No. or prototype:  
 - Serial No.:

**1.2 Mass of unballasted tractor, with protective structure fitted and without driver**

Front	kg
Rear	kg
Total	kg

- Maximum permissible mass of tractor: kg
- Reference mass used for calculating impact energies and crushing forces: kg
- Mass Ratio value - (*Maximum Permissible Mass / Reference Mass*): .....

**1.3 Wheelbase and moment of inertia**

- Wheelbase of the tested tractor: mm
- Moment of inertia used for calculating impact energy at the rear: kgm<sup>2</sup>



**1.4 Test tyre or track dimensions and track settings**

	Minimum track	Tyres/Tracks		
		Dimensions	Diameter	Pressure
	mm	mm	mm	kPa
Front				
Rear				

**1.5 Tractor seat**

- Tractor with a reversible driver’s position (reversible seat and steering wheel): Yes / No
- Make/type/model of seat:

Make/type/model of optional seat(s) and position(s) of the seat index point (SIP) (*only for driver seats*):

(description of seat 1 and SIP position)

(description of seat 2 and SIP position)

(description of seat \_ and SIP position)

- Seat belt anchorage: Type
- Seat mounting on the tractor: Type
- Other seat components: Type
- Seat operating position in the test: Description

**Masses used for calculating the loads**

Seat	Make/Model/Type
COMPONENTS	MASS (kg)
Driver seat:	
Seat belt assembly:	
Other seat components:	
Total:	

**2. SPECIFICATIONS OF PROTECTIVE STRUCTURE**

**2.1 Photographs from side and rear** showing mounting details including mudguards

**2.2 General arrangement drawing of the side and the rear** of the structure including position of the seat index points (SIP), details of mountings and position of the front part of the tractor capable of supporting the tractor when overturned (if necessary). General description of the protective structure's shape and construction (normally at least a scale of 1/ 20 for the general drawings and 1/ 2.5 for drawing of the attachments). The main dimensions must figure on the drawings, including external dimensions of tractor with protective structure fitted and main interior dimensions.

**2.3 Brief description** of the protective structure comprising:

- type of construction;
- details of mountings;
- details of cladding and padding;
- details of the front part of the tractor capable of supporting the tractor when overturned (if necessary);
- means of access and escape;
- additional frame: Yes/No

## 2.4 Tiltable/not tiltable structure

- Tiltable / not tiltable (\*)
  - If it is necessary to tilt with any tools, this should be stated as follows:
  - Tiltable with tools/ tiltable without tools (\*)
- Folding/ not folding (\*)
  - If it is necessary to fold with any tools, this should be stated as follows:
  - Folding with tools/ folding without tools (\*)

(\*) delete as appropriate

## 2.5 Dimensions

Dimensions should be measured with seatpan and backrest loaded and adjusted according to Definition 1.5 of the Code.

When the tractor is fitted with different optional seats or has a reversible driver's position (reversible seat and steering wheel), the dimensions in relation to the seat index points shall be measured in each case (SIP 1, SIP 2, etc.).

- |       |  |    |
|-------|--|----|
| 2.5.1 | Height of roof members above the seat index point:   | mm |
| 2.5.2 | Height of roof members above the tractor footplate:  | mm |
| 2.5.3 | Interior width of the protective structure<br>(810 + $a_v$ ) mm above the seat index point:  | mm |
| 2.5.4 | Interior width of the protective structure vertically above the seat index point at the level of centre of the steering wheel:                     | mm |
| 2.5.5 | Distance from the centre of the steering wheel to the right-hand side of the protective structure:   | mm |
| 2.5.6 | Distance from the centre of the steering wheel to the left-hand side of the protective structure:  | mm |
| 2.5.7 | Minimum distance from the steering wheel rim to the protective structure:  | mm |
| 2.5.8 | Horizontal distance from the seat index point to the rear of the protective structure at a height of (810 + $a_v$ ) mm above the seat index point: | mm |
| 2.5.9 | Minimum overall width of the tractor ( <b>B</b> ):   | mm |

- 2.5.10 Maximum outer width of the protective structure ( **Bb**): mm
- 2.5.11 Position (with reference to the rear axle) of the front part of the tractor capable of supporting the tractor when overturned (if necessary):
- horizontal distance: mm
  - vertical distance: mm

**2.6 Details of materials used in the construction of the protective structure and steel specifications**

Steel specifications shall be in conformity with ISO 630-1,2,3,4:2011-2012.

- 2.6.1 Main frame: (parts - material - sizes)
- Is steel rimmed, semi-killed or killed
  - steel standard and reference:
- 2.6.2 Mountings: (parts - material - sizes)
- Is steel rimmed, semi-killed or killed
  - steel standard and reference:
- 2.6.3 Assembly and mounting bolts: (parts - sizes)
- 2.6.4 Roof: (parts - material - sizes)
- 2.6.5 Cladding: (parts - material - sizes)
- 2.6.6 Glass: (type - grade - sizes)
- 2.6.7 Front part of the tractor capable of supporting the tractor when overturned (if necessary) (parts - material - sizes)

**2.7. Details of tractor manufacturer's reinforcements on original parts**

### 3. TEST RESULTS

#### 3.1 Preliminary tests of lateral stability and non-continuous rolling

Make/Type/Model of tractor to which the structure is fitted:

When several tractors are subjected to preliminary tests of lateral stability and non-continuous rolling, this report presentation should be used for each tractor tested.

##### 3.1.1 Lateral stability test (Statement)

The tractor was resting on wheels or tracks touching the ground in a state of unstable equilibrium at an angle of inclination of at least 38° from the vertical; therefore, conditions for lateral stability were fulfilled.

##### 3.1.2 Non-continuous rolling test

Mention chosen method according to paragraph 3.1.4.2 or 3.1.4.3 of the Code.

###### 3.1.2.1 Demonstration of non-continuous rolling behaviour by means of the overturning test

The tractor was subjected to an overturning test and did not roll over. Therefore, it fulfils the conditions required for the non-continuous rolling test.

###### 3.1.2.2 Demonstration of non-continuous rolling behaviour by calculation

Without an overturning test, non-continuous rolling behaviour was demonstrated by calculation, on the basis of the following measurements:

3.1.2.2.1	Height of centre of gravity:	<b>(H<sub>1</sub>)</b>	m
3.1.2.2.2	Horizontal distance between the centre of gravity and front axle:	<b>(L<sub>2</sub>)</b>	m
3.1.2.2.3	Horizontal distance between the centre of gravity and rear axle:	<b>(L<sub>3</sub>)</b>	m
3.1.2.2.4	Height of front tyres or tracks under full axle load:	<b>(D<sub>2</sub>)</b>	m
3.1.2.2.5	Height of rear tyres or tracks under full axle load:	<b>(D<sub>3</sub>)</b>	m
3.1.2.2.6	Height at the point of impact:	<b>(H<sub>6</sub>)</b>	m
3.1.2.2.7	Horizontal distance between the centre of gravity and the leading point of intersection of the protective structure (to be preceded by a minus sign if this point lies in front of the plane of the centre of gravity):	<b>(L<sub>6</sub>)</b>	m
3.1.2.2.8	Minimum outer width of the tractor	<b>(B)</b>	m
3.1.2.2.9	Width of protective structure between the right and left points of impact:	<b>(B<sub>6</sub>)</b>	m
3.1.2.2.10	Height of engine bonnet:	<b>(H<sub>7</sub>)</b>	m
3.1.2.2.11	Width of engine bonnet:	<b>(B<sub>7</sub>)</b>	m
3.1.2.2.12	Horizontal distance between the centre of gravity and		

the front corner of the engine bonnet:	(L7)	m
3.1.2.2.13 Height of the front-axle pivot point:	(H0)	m
3.1.2.2.14 Rear track width	(S)	m
3.1.2.2.15 Rear tyre or track width:	(B0)	m
3.1.2.2.16 Front-axle swing angle from zero position to end of travel:	(D0)	radian
3.1.2.2.17 Tractor mass used for calculation:	(Mc)	kg
3.1.2.2.18 Moment of inertia about the longitudinal axis through the centre of gravity:	(Q)	kgm <sup>2</sup>

The sum of track (**S**) and tyre or tracks (**B<sub>o</sub>**) width must be greater than the width (**B<sub>6</sub>**) of the protective structure, as follows:

$$S + B_o - B_6 > 0$$

Therefore, the tractor fulfils the conditions required for non-continuous rolling behaviour.

**Lateral stability and non-continuous rolling tests being established in accordance with the Code, the protective structure is eligible for the strength test.**

### 3.2 Impact/Loading and crushing tests

#### 3.2.1 Conditions of tests

Impact tests/loading tests were made:

- to the rear left/right,
- to the front right/left,
- to the side right/left.

Mass used for calculating energies and loading forces: kg

Wheelbase used for calculating energy at the rear: mm

Moment of inertia used for calculating energy at the rear: kgm<sup>2</sup>

Energies and forces applied to the front frame:

- rear: kJ
- front: kJ
- side: kJ
- crushing forces: kN
- during additional overload test: kJ

Force applied to the rear frame: kN

3.2.2 Permanent deflections measured after the tests

3.2.2.1 Permanent deflections of the extremities of the protective structure measured after the series of tests:

Back (forwards/ backwards):

- left-hand: mm
- right-hand: mm

Front (forwards/ backwards):

- left-hand: mm
- right-hand: mm

Sideways (to the left/ to the right):

- front: mm
- rear: mm

Top (downwards/ upwards):

- rear: left-hand: mm
- right-hand: mm
- front: left-hand: mm
- right-hand: mm

3.2.2.2 Difference between total instantaneous deflection and residual deflection (elastic deflection) during:

- sideways impact test (dynamic test): mm
- or,
- sideways loading test (static test): mm

3.2.3 Indication and results of any additional test

3.2.4 Curves

A copy of the force/deflection curves derived during the test shall be included (in case of a static test).

If a horizontal overload test was required, the reason for the overload shall be described and the copy of additional force/deflection curves obtained during overload shall be included.

**Statement:**

**The acceptance conditions of these tests relative to the protection of the clearance zone are fulfilled. The structure is a roll-over protective structure in accordance with the Code.**

**3.3 Cold weather performance (resistance to brittle fracture)**

Method used to identify resistance to brittle fracture at reduced temperature:

- 
- 

Steel specifications shall be in conformity with ISO 630-1,2,3,4:2011-2012.

Steel specification: (reference and relevant standard)

**3.4 Seat belt anchorage performance**

3.4.1 Loading in the forward and upward direction

Driver seat	Make/Model/Type	
GRAVITY FORCE ( $F_g = \text{seat mass} \times 9.81$ ) N	REQUIRED FORCE ( $4450 + 4 F_g$ ) N	APPLIED FORCE  N

3.4.2 Loading in the rearward and upward direction

Driver seat	Make/Model/Type	
GRAVITY FORCE ( $F_g = \text{seat mass} \times 9.81$ ) N	REQUIRED FORCE ( $2225 + 2 F_g$ ) N	APPLIED FORCE  N

3.4.3 Curves, drawings and photos

A copy of the force/deflection curves derived during the tests shall be included.

Drawings and/or photos of the seat mounting and anchorages have to be added.

**Statement (if necessary):**

**The testing station certifies that the tested seat is the worst variant among the seats listed below that are identical regarding the seatbelt anchorage performance test.**

**Statement:**

**During the test, no structural failure or release of seat, seat adjuster mechanism or other locking service occurred. The seat and safety belt anchorage tested fulfil the requirement of the OECD procedure.**

**3.5 Front “Hand operated” Folding ROPS performance**

3.5.1 Drawings and/or photos related to the Foldable ROPS components, if any (such as manual or automatic locking system, partial handling assistance, etc.) have to be added.

3.5.2 Drawings and/or photos showing the grasping area, clearly and permanently identified in accordance with the OECD requirements given in paragraph 3.8.3.1, have to be added.

3.5.3 In case additional handles are involved on the grasping area, the related details/specifications shall be provided (part, sizes and assembly, if any).

3.5.4 The acceptable force needed for the actuation of the ROPS and measured in accordance with the OECD requirements given in paragraph 3.8.3.3 is:

Force requirement point	A	A'	A''	B
Zone (I or II or III)				
Raising operation Force measured (N)				
Lowering operation Force measured (N)				

3.5.5 The automatic locking system was submitted to 500 cycles and the force applied fulfils the requirement.  
or,

The manufacturer declares that the preliminary test was carried out according to the test procedure in the point 3.8.5 and there were no maintenance or adjustment on the locking system after the completion of the 500 cycles. The test station checked the performance of the device provided by the manufacturer.

**Statement:**

- **No shearing, pinching or uncontrollable movement hazards to the operator results from the manual raise or lower handling of the roll-bar.**
- **All the conditions prior to the performance of test, have been followed in accordance with the provisions given in 3.8.3.1;**
- **The test has been performed in accordance with the procedure given in 3.8.3.2;**
- **The condition of acceptance as well as the additional requirements given in 3.8.3.3 has been verified;**
- **The Hand locking system, (if any) is in accordance with paragraph 3.8.4.**
- **The Foldable ROPS performance fulfils the requirements of the OECD procedure.**

**3.6 Tractor(s) to which the protective structure is fitted**

OECD Approval Number :										
Make	Model	Type <i>2/4 WD, etc</i>	Other specifications <i>where applicable</i>	Mass			Tiltable <i>Yes/ No</i>	Wheel-Base <i>mm</i>	Minimum track	
				Front <i>kg</i>	Rear <i>kg</i>	Total <i>kg</i>			Front	Rear



--	--	--	--	--	--	--	--	--	--	--

## SPECIMEN TECHNICAL EXTENSION REPORT

**Note:** Units shown below, which appear in ISO 80000-1:2009/Cor.1:2011, shall be stated and followed by national units in parentheses, if necessary.

- Protective structure manufacturer's name and address:
- Submission for extension by:
  
- Make of the protective structure:
- Model of the protective structure:
- Type of the protective structure: *Cab, Frame, Rear rollbar, Cab with integrated frame, etc.*
  
- Date, location of extension and Code version:
  
- Reference of the original test:
- Approval number and date of the original test report:
  
- Statement giving the reasons of the extension and explaining the procedure chosen (e.g. extension with validation test):

Depending on the case some of the following paragraphs may be omitted if their content is identical to the one of the original test report. It is only necessary to highlight the differences between the tractor and protective structure described in the original test report and the one for which the extension has been required.

### 1. SPECIFICATIONS OF TEST TRACTOR

#### 1.1 Identification of tractor to which the protective structure is fitted for the test

- 1.1.1 - Make of the tractor: (\*)  
- Model (trade name):  
- Type: 2 *WD* or 4 *WD*; *rubber or steel tracks (if applicable)*;  
*articulated 4 WD or articulated 4 WD with twin (dual) wheels (if applicable)*  
(\*) possibly different from tractor manufacturer's name

- 1.1.2 Numbers  
- 1<sup>st</sup> Serial No. or prototype:  
- Serial No.:

**1.2 Mass of unballasted tractor, with protective structure fitted and without driver**

Front	kg
Rear	kg
Total	kg

- Maximum permissible mass of tractor: kg
- Reference mass used for calculating impact energies and crushing forces: kg
- Mass Ratio value - (*Maximum Permissible Mass / Reference Mass*): .....

**1.3 Wheelbase and moment of inertia**

- Wheelbase of the tested tractor: mm
- Moment of inertia used for calculating impact energy at the rear: kgm<sup>2</sup>

**1.4 Test tyre or track dimensions and track settings**

	Minimum track	Tyres/Tracks		
		Dimensions	Diameter	Pressure
	mm	mm	mm	kPa
Front				
Rear				

**1.5 Tractor seat**

- Tractor with a reversible driver’s position (reversible seat and steering wheel): Yes / No
- Make/type/model of seat:

Make/type/model of optional seat(s) and position(s) of the seat index point (SIP) (*only for driver seats*):

(description of seat 1 and SIP position)

(description of seat 2 and SIP position)

(description of seat \_ and SIP position)

- Seat belt anchorage: Type
- Seat mounting on the tractor: Type
- Other seat components: Type
- Seat operating position in the test: Description

**Masses used for calculating the loads**

Seat	Make/Model/Type
COMPONENTS	MASS (Kg)
Driver seat:	
Seat belt assembly:	

Other seat components:	
Total:	

**2. SPECIFICATIONS OF PROTECTIVE STRUCTURE**

**2.1 Photographs from side and rear** showing mounting details including mudguards

**2.2 General arrangement drawing of the side and the rear** of the structure including position of the seat index points (SIP), details of mountings and position of the front part of the tractor capable of supporting the tractor when overturned (if necessary). General description of the protective structure's shape and construction (normally at least a scale of 1/ 20 for the general drawings and 1/ 2.5 for drawing of the attachments). The main dimensions must figure on the drawings, including external dimensions of tractor with protective structure fitted and main interior dimensions.

**2.3 Brief description** of the protective structure comprising:

- type of construction;
- details of mountings;
- details of cladding and padding;
- details of the front part of the tractor capable of supporting the tractor when overturned (if necessary);
- means of access and escape;
- additional frame: Yes/No

**2.4 Tiltable/not tiltable structure**

- Tiltable / not tiltable (\*)  
 If it is necessary to tilt with any tools, this should be stated as follows:  
 -- Tiltable with tools/ tiltable without tools (\*)
- Folding/ not folding (\*)  
 If it is necessary to fold with any tools, this should be stated as follows:  
 -- Folding with tools/ folding without tools (\*)

(\*) *delete as appropriate*

**2.5 Dimensions**

Dimensions should be measured with seatpan and backrest loaded and adjusted according to Definition 1.5 of the Code.

When the tractor is fitted with different optional seats or has a reversible driver's position (reversible seat and steering wheel), the dimensions in relation to the seat index points shall be measured in each case (SIP 1, SIP 2, etc.).

- 2.5.1 Height of roof members above the seat index point: mm
- 2.5.2 Height of roof members above the tractor footplate: mm
- 2.5.3 Interior width of the protective structure

	(810 + $a_v$ ) mm above the seat index point:	mm
2.5.4	Interior width of the protective structure vertically above the seat index point at the level of centre of the steering wheel:	mm
2.5.5	Distance from the centre of the steering wheel to the right-hand side of the protective structure:	mm
2.5.6	Distance from the centre of the steering wheel to the left-hand side of the protective structure:	mm
2.5.7	Minimum distance from the steering wheel rim to the protective structure:	mm
2.5.8	Horizontal distance from the seat index point to the rear of the protective structure at a height of (810 + $a_v$ ) mm above the seat index point:	mm
2.5.9	Minimum overall width of the tractor ( <b>B</b> ):	mm
2.5.10	Maximum outer width of the protective structure ( <b>B<sub>b</sub></b> ):	mm
2.5.11	Position (with reference to the rear axle) of the front part of the tractor capable of supporting the tractor when overturned (if necessary)	
	• horizontal distance:	mm
	• vertical distance:	mm

**2.6 Details of materials used in the construction of the protective structure and steel specifications**

Steel specifications shall be in conformity with ISO 630-1,2,3,4:2011-2012.

2.6.1	Main frame:	(parts - material - sizes)
	• Is steel rimmed, semi-killed or killed	
	• steel standard and reference:	
2.6.2	Mountings:	(parts - material - sizes)
	• Is steel rimmed, semi-killed or killed	
	• steel standard and reference:	
2.6.3	Assembly and mounting bolts:	(parts - sizes)
2.6.4	Roof:	(parts - material - sizes)
2.6.5	Cladding:	(parts - material - sizes)
2.6.6	Glass:	(type - grade - sizes)
2.6.7	Front part of the tractor capable of supporting the tractor when overturned (if necessary)	(parts - material - sizes)

**2.7. Details of tractor manufacturer's reinforcements on original parts**

### 3. TEST RESULTS (in case of validation test)

#### 3.1 Preliminary tests of lateral stability and non-continuous rolling

Make/Type/Model of tractor to which the structure is fitted:

When several tractors are subjected to preliminary tests of lateral stability and non-continuous rolling, this report presentation should be used for each tractor tested.

##### 3.1.1 Lateral stability test (Statement)

The tractor was resting on wheels or tracks touching the ground in a state of unstable equilibrium at an angle of inclination of at least 38° from the vertical; therefore, conditions for lateral stability were fulfilled.

##### 3.1.2 Non-continuous rolling test

Mention chosen method according to paragraph 3.1.4.2 or 3.1.4.3 of the Code.

###### 3.1.2.1 Demonstration of non-continuous rolling behaviour by means of the overturning test

The tractor was subjected to an overturning test and did not roll over. Therefore, it fulfils the conditions required for the non-continuous rolling test.

###### 3.1.2.2 Demonstration of non-continuous rolling behaviour by calculation

Without an overturning test, non-continuous rolling behaviour was demonstrated by calculation, on the basis of the following measurements:

3.1.2.2.1	Height of centre of gravity:	(H <sub>1</sub> )	m
3.1.2.2.2	Horizontal distance between the centre of gravity and front axle:	(L <sub>2</sub> )	m
3.1.2.2.3	Horizontal distance between the centre of gravity and rear axle:	(L <sub>3</sub> )	m
3.1.2.2.4	Height of front tyres or tracks under full axle load:	(D <sub>2</sub> )	m
3.1.2.2.5	Height of rear tyres or tracks under full axle load:	(D <sub>3</sub> )	m
3.1.2.2.6	Height at the point of impact:	(H <sub>6</sub> )	m
3.1.2.2.7	Horizontal distance between the centre of gravity and the leading point of intersection of the protective structure (to be preceded by a minus sign if this point lies in front of the plane of the centre of gravity):	(L <sub>6</sub> )	m
3.1.2.2.8	Minimum outer width of the tractor	(B)	m
3.1.2.2.9	Width of protective structure between the right and left points of impact:	(B <sub>6</sub> )	m
3.1.2.2.10	Height of engine bonnet:	(H <sub>7</sub> )	m
3.1.2.2.11	Width of engine bonnet:	(B <sub>7</sub> )	m
3.1.2.2.12	Horizontal distance between the centre of gravity and		

the front corner of the engine bonnet:	(L7)	m
3.1.2.2.13 Height of the front-axle pivot point:	(H0)	m
3.1.2.2.14 Rear track width	(S)	m
3.1.2.2.15 Rear tyre or track width:	(B0)	m
3.1.2.2.16 Front-axle swing angle from zero position to end of travel:	(D0)	radian
3.1.2.2.17 Tractor mass used for calculation:	(Mc)	kg
3.1.2.2.18 Moment of inertia about the longitudinal axis through the centre of gravity: (Q)		kgm <sup>2</sup>

The sum of track (S) and tyre or tracks (B<sub>0</sub>) width must be greater than the width (B<sub>6</sub>) of the protective structure, as follows:

$$S + B_0 - B_6 > 0$$

Therefore, the tractor fulfils the conditions required for non-continuous rolling behaviour.

**Lateral stability and non-continuous rolling tests being established in accordance with the Code, the protective structure is eligible for the strength test.**

## 3.2 Impact/Loading and crushing tests

### 3.2.1 Conditions of tests

Impact tests/loading tests were made:

- to the rear left/right,
- to the front right/left,
- to the side right/left.

Mass used for calculating energies and loading forces: kg

Wheelbase used for calculating energy at the rear: mm

Moment of inertia used for calculating energy at the rear: kgm<sup>2</sup>





The test station has checked the modifications and certifies that the effect of these modifications do not affect the results on the strength of the protective structure.

The acceptance conditions relative to the protection of the clearance zone are fulfilled. The structure is a roll-over protective structure in accordance with the Code.

3.2.4 Curves

A copy of the force/deflection curves derived during the tests shall be included (in the case of a static validation test).

	Deflection measured when required energy level has been reached			Force measured when required energy level has been reached <sup>4</sup>		
	original test mm	validation test mm	relative deviation %	original test kN	validation test kN	relative deviation %
First longitudinal loading test						
Lateral loading test						
Second longitudinal test						

If a horizontal overload test was required, the reason for the overload shall be described and the copy of additional force/deflection curves obtained during overload shall be included.

**3.3 Cold weather performance (resistance to brittle fracture)**

Method used to identify resistance to brittle fracture at reduced temperature:

- 
- 

Steel specifications shall be in conformity with ISO 630-1,2,3,4:2011-2012.

Steel specification: (reference and relevant standard)

---

<sup>4</sup> In case of a dynamic test this part of the table shall not be provided and ‘loading test’ shall be replaced by ‘impact test’

**3.4 Seat belt anchorage performance**

3.4.1 Loading in the forward and upward direction

Driver seat	Make/Model/Type	
GRAVITY FORCE ( $F_g = \text{seat mass} \times 9.81$ ) N	REQUIRED FORCE ( $4450 + 4 F_g$ ) N	APPLIED FORCE  N

3.4.2. Loading in the rearward and upward direction

Driver seat	Make/Model/Type	
GRAVITY FORCE ( $F_g = \text{seat mass} \times 9.81$ ) N	REQUIRED FORCE ( $2225 + 2 F_g$ ) N	APPLIED FORCE  N

3.4.3 Curves, drawings and photos

A copy of the force/deflection curves derived during the tests shall be included.

Drawings and/or photos of the seat mounting and anchorages have to be added.

**Statement:**

**During the test, no structural failure or release of seat, seat adjuster mechanism or other locking service occurred. The seat and safety belt anchorage tested fulfil the requirement of the OECD procedure.**

**3.5 Front “Hand operated” Folding ROPS performance**

3.5.1 Drawings and/or photos related to the Foldable ROPS components, if any (such as manual or automatic locking system, partial handling assistance, etc.) have to be added.

3.5.2 Drawings and/or photos showing the grasping area, clearly and permanently identified in accordance with the OECD requirements given in paragraph 3.8.3.1, have to be added.

3.5.3 In case additional handles are involved on the grasping area, the related details/specifications shall be provided (part, sizes and assembly, if any).

3.5.4 The acceptable force needed for the actuation of the ROPS and measured in accordance with the OECD requirements given in paragraph 3.8.3.3 is:

Force requirement point	A	A'	A''	B
Zone (I or II or III)				
Raising operation Force measured (N)				
Lowering operation Force measured (N)				

3.5.5 The automatic locking system was submitted to 500 cycles and the force applied fulfils the requirement.  
or,

The manufacturer declares that the preliminary test was carried out according to the test procedure in the point 3.8.5 and there were no maintenance or adjustment on the locking system after the completion of the 500 cycles. The test station checked the performance of the device provided by the manufacturer.

**Statement:**

- **No shearing, pinching or uncontrollable movement hazards to the operator results from the manual raise or lower handling of the roll-bar.**
- **All the conditions prior to the performance of test, have been followed in accordance with the provisions given in 3.8.3.1;**
- **The test has been performed in accordance with the procedure given in 3.8.3.2;**
- **The condition of acceptance as well as the additional requirements given in 3.8.3.3 has been verified;**
- **The Hand locking system, (if any) is in accordance with paragraph 3.8.4.**
- **The Foldable ROPS performance fulfils the requirements of the OECD procedure.**

**3.6 Tractor(s) to which the protective structure is fitted**

OECD Approval Number:										
Make	Model	Type	Other specifications	Mass			Tiltable	Wheel-Base	Minimum track	
				Front	Rear	Total			Front	Rear
		<i>2/4 WD, etc</i>	<i>where applicable</i>	kg	kg	kg	<i>Yes/No</i>	mm	mm	

**SPECIMEN ADMINISTRATIVE EXTENSION REPORT**

**Note:** Units shown below, which appear in ISO 80000-1:2009/Cor.1:2011, shall be stated and followed by national units in parentheses, if necessary.

- Submitted for extension by:
- Date, location of extension and Code version:
- Reference of the original test:
- Approval number and date of the original test:
- Statement giving the reasons of the extension and explaining the procedure chosen.

**1. Specification of the protective structure**

- Frame or Cab:
- Manufacturer:
- Make:
- Model:
- Type:
- Serial Number from which modification applies:

**2. Denomination of tractor(s) to which the protective structure is fitted**

OECD Approval Number:										
Make	Model	Type	Other specifications	Mass			Tiltable	Wheel-Base	Minimum track	
				Front	Rear	Total			Front	Rear
		<i>2/4 WD, etc</i>	<i>where applicable</i>	kg	kg	kg	<i>Yes/No</i>	mm	mm	

**3. Details of modifications**

Since the original test report the following modifications have been made:

\_\_\_\_\_

\_\_\_\_\_

\_\_\_\_\_

**4. Statement**

**The modifications do not to affect the results of the original test.**

**The original test report therefore applies.**

**ANNEX I**

**CLEARANCE ZONE REFERRED TO  
THE SEAT REFERENCE POINT**

## INTRODUCTION

The paragraphs considered in the Annex refer to the definitions of the seat reference point (SRP) and the clearance zone of ROPS based on the SRP as the reference point. The numbering of the paragraphs is the same of the corresponding paragraphs in the main Code.

In the case of extension reports to test reports that originally used SRP, required measurements shall be made with reference to SRP instead of SIP. Moreover, the use of SRP shall be clearly indicated. For drafting such extension reports, the paragraphs detailed in the Annex should be followed. For the paragraphs non-reported in the Annex, previous version of Code 6 should be considered.

### 1. DEFINITIONS

#### 1.5 *Determination of seat reference point; Seat location and adjustment for test*

##### 1.5.1 Seat reference point

1.5.1.1 The reference must be established by means of the apparatus illustrated in Figures 6.20, 6.21 and 6.22. The apparatus consists of a seat pan board and backrest boards. The lower backrest board is jointed in the region of the ischium humps (**A**) and loin (**B**), the joint (**B**) being adjustable in height.

1.5.1.2 The seat reference point is defined as the point in the median longitudinal plane of the seat where the tangential plane of the lower backrest and a horizontal plane intersect. This horizontal plane cuts the lower surface of the seat pan board 150 mm in front of the above-mentioned tangent.

1.5.1.3 The apparatus is positioned on the seat. It is then loaded with a force of 550 N at a point 50 mm in front of joint (A), and the two parts of the backrest board lightly pressed tangentially against the backrest.

1.5.1.4 If it is not possible to determine definite tangents to each area of the backrest (above and below the lumbar region), the following steps must be taken:

where no definite tangent to the lower area is possible, the lower part of the backrest board is pressed against the backrest vertically;

where no definite tangent to the upper area is possible, the point (**B**) is fixed at a height of 230 mm above the lower surface of the seat pan board, the backrest board being perpendicular to the seat pan board. Then the two parts of the backrest board are lightly pressed against the backrest tangentially.

##### 1.5.2 Seat location and adjustment for test

1.5.2.1 Where the seat position is adjustable, the seat must be adjusted to its rear uppermost position;

1.5.2.2 where the inclination of the backrest and seat pan is adjustable, these must be adjusted so that the reference point is in its rear uppermost position;

1.5.2.3 where the seat is equipped with suspension, the latter must be blocked at mid-travel, unless this is contrary to the instructions clearly laid down by the seat manufacturer;

1.5.2.4 where the position of the seat is adjustable only lengthwise and vertically, the longitudinal axis passing through the seat reference point shall be parallel with the vertical longitudinal plane of the tractor passing through the centre of the steering wheel and not more than 100 mm from that plane.

## 1.6 Clearance zone

### 1.6.1 Reference vertical plane and line

The clearance zone (Figures 6.23 and 6.24) is defined on the basis of a vertical reference plane and a reference line:

1.6.1.1 The vertical reference plane, generally longitudinal to the tractor, is passing through the seat reference point and the centre of the steering wheel; normally, the vertical reference plane coincides with the median plane of the tractor. This plane must be able to move horizontally with the seat and steering wheel during impacts and loads, but to remain perpendicular to the floor of the tractor or of the protective structure if this is resiliently mounted.

1.6.1.2 The reference line contained in the reference plane passes through the seat reference point and the first point on the steering wheel rim that it intersects when brought to the horizontal.

### 1.6.2 Determination of clearance zone

The clearance zone is bounded by the following planes, the tractor being on a horizontal surface and, where the steering wheel is adjustable, its position adjusted for the middle position for driving:

1.6.2.1 two vertical planes 250 mm on either side of the reference plane, these vertical planes extending 300 mm upwards from the horizontal plane passing through the seat reference point and longitudinally at least 550 mm in front of the vertical plane perpendicular to the reference plane passing 350 mm in front of the seat reference point;

1.6.2.2 two vertical planes 200 mm on either side of the reference plane, these vertical planes extending 300 mm upwards from the horizontal plane passing through the seat reference point and longitudinally from the surface defined in 1.6.2.1 to the vertical plane perpendicular to the reference plane passing 350 mm in front of the seat reference point;

1.6.2.3 an inclined plane perpendicular to the reference plane, parallel with and 400 mm above the reference line, extending backwards to the point where it intersects the vertical plane which is perpendicular to the reference plane and which passes through the seat reference point;

1.6.2.4 an inclined plane, perpendicular to the reference plane and resting on the top of the seat backrest, which meets the previous plane at its rearmost edge;

1.6.2.5 a vertical plane perpendicular to the reference plane, passing at least 40 mm forward of the steering wheel and at least 900 mm forward of the seat reference point;

1.6.2.6 a cylindrical surface with its axis perpendicular to the reference plane, having a radius of 150 mm and meeting the planes defined in 1.6.2.3 and 1.6.2.5 at a tangent;

1.6.2.7 two parallel inclined planes passing through the upper edges of the planes defined in 1.6.2.1 with the inclined plane on the side where the impact is applied no closer than 100 mm to the reference plane above the clearance zone;

1.6.2.8 a horizontal plane passing through the seat reference point;

1.6.2.9 two portions of the vertical plane perpendicular to the reference plane passing 350 mm forward of the seat reference point, both these part planes joining respectively the rearmost limits of the planes defined in 1.6.2.1 to the foremost limits of the planes defined in 1.6.2.2;

1.6.2.10 two portions of the horizontal plane passing 300 mm above the seat reference point, both these part planes joining respectively the uppermost limits of the vertical planes defined in 1.6.2.2 to the lowermost limits of the oblique planes defined in 1.6.2.7;

1.6.2.11 a curvilinear surface whose generating line is perpendicular to the reference plane and rests on the back of the seat backrest.

### 1.6.3 Tractors with a reversible driver's position

For tractors with a reversible driver's position (reversible seat and steering wheel), the clearance zone is the envelope of the two clearance zones defined by the different positions of the steering wheel and the seat. For each position of steering wheel and the seat the clearance zone shall respectively be defined on the basis of above sections 1.6.1 and 1.6.2 of present Code for driver's position in normal position and on the basis of sections 1.6.1 and 1.6.2 of Code 7 for driver's position in reverse position (Figure 6.25).

### 1.6.4 Optional seats

1.6.4.1 In case of tractors that could be fitted with optional seats, the envelope comprising the seat reference points of all the options offered shall be used during the tests. The protective structure shall not enter the larger clearance zone which takes account of these different seat reference points.

1.6.4.2 In the case where a new seat option is offered after the test has been performed, a determination shall be made to see whether the clearance zone around the new SRP falls within the envelope previously established. If it does not, a new test must be performed.



Dimensions in mm

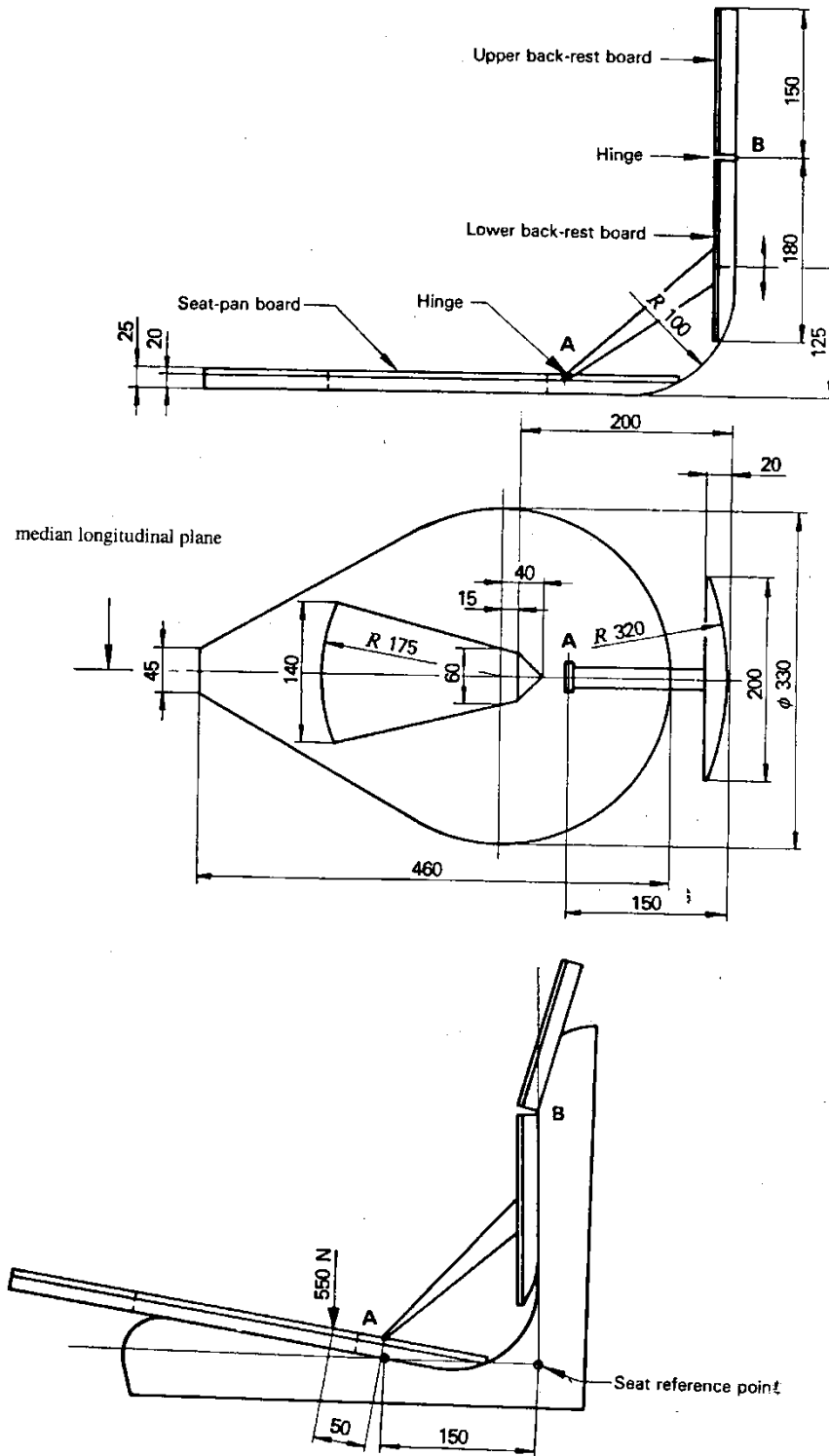

Figures 6.20, 6.21 and 6.22

**Apparatus for determination of seat reference point**

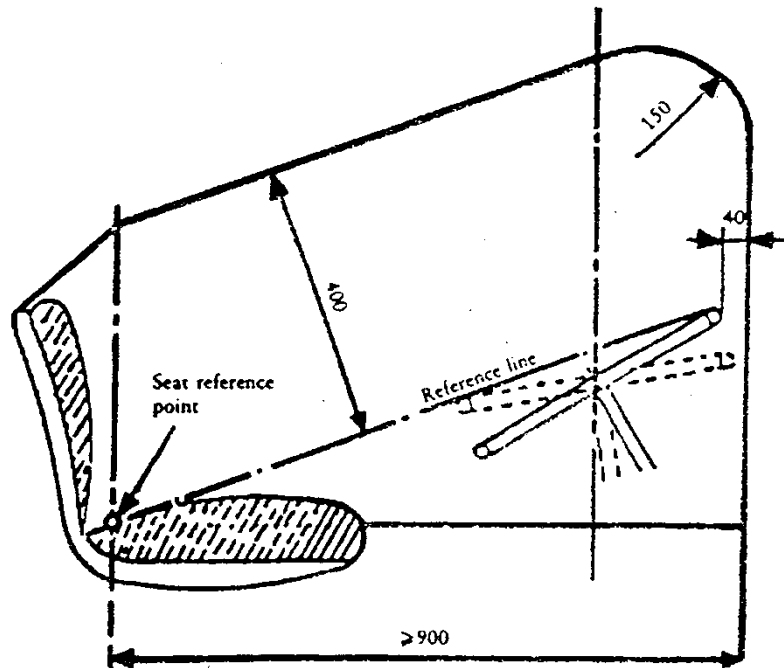

Cross-section through the reference plane

Figure 6.23

**Clearance zone**

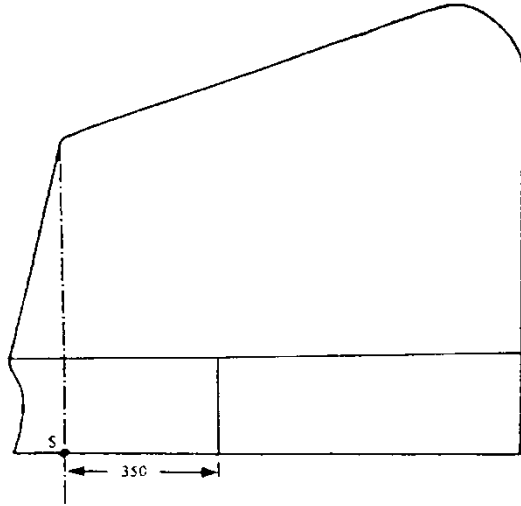

Side view

Figure 6.24.a

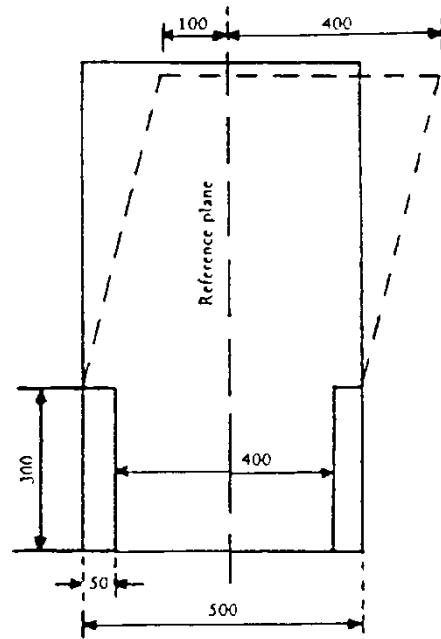

Rear view

Figure 6.24.b

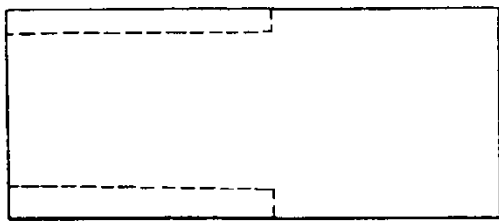

Seen from above

Figure 6.24.c

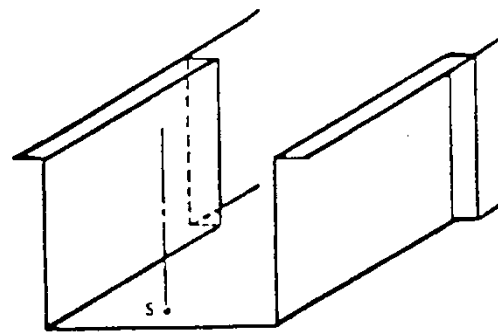

Lower part, 3/4 rear view

Figure 6.24.d

Figure 6.24

**Clearance zone**

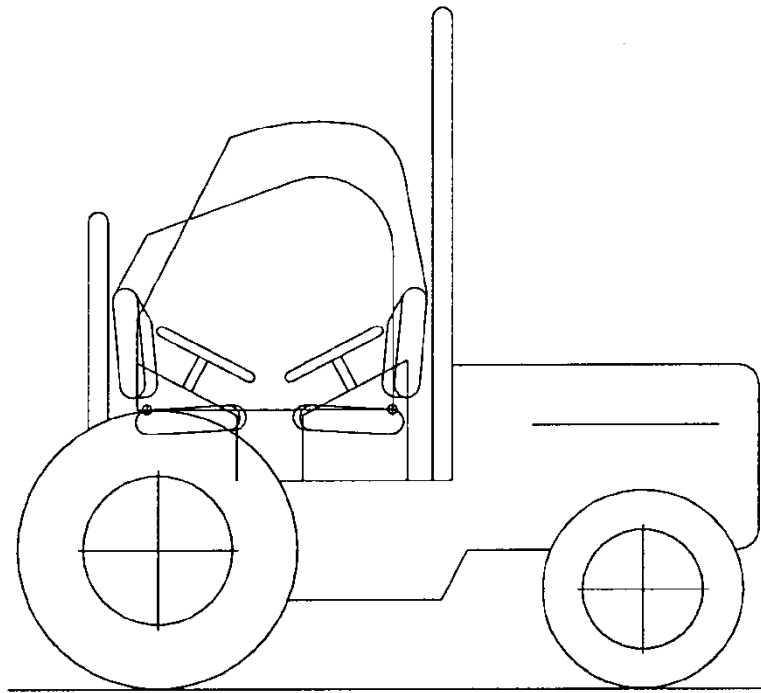

Figure 6.25

**Clearance zone for tractors with reversible seat and steering wheel**

**ANNEX II**

**DYNAMIC TEST METHOD**

## INTRODUCTION

The paragraphs considered in this Annex refer to the Dynamic Testing Procedure. Tests may be performed in accordance with the dynamic or the static test procedure. The two methods are deemed equivalent. In general the numbering of the sections within this Annex relates to corresponding sections in the main Code.

### 3. RULES AND DIRECTIONS

#### 3.1 *Prior conditions for the strength tests*

See requirements stated in the main Code.

#### 3.2 *Conditions for testing the strength of protective structures and of their attachment to tractors*

##### 3.2.1 General requirements

See requirements stated in the main Code.

##### 3.2.2 Tests

###### 3.2.2.1 Sequence of tests according to the Dynamic Procedure

The sequence of tests, without prejudice to the additional tests mentioned in sections 3.3.1.6 and 3.3.1.7 is as follows:

- (1) **impact at the rear of the structure**  
(see 3.3.1.1);
- (2) **rear crushing test**  
(see 3.3.1.4);
- (3) **impact at the front of the structure**  
(see 3.3.1.2);
- (4) **impact at the side of the structure**  
(see 3.3.1.3);
- (5) **crushing at the front of the structure**  
(see 3.3.1.5).

###### 3.2.2.2 General requirements

3.2.2.2.1 If, during the test, any part of the tractor restraining equipment breaks or moves, the test shall be restarted.

3.2.2.2.2 No repairs or adjustments of the tractor or protective structure may be carried out during the tests.

3.2.2.2.3 The tractor gear box shall be in neutral and the brakes off during the tests.

3.2.2.2.4 If the tractor is fitted with a suspension system between the tractor body and the wheels, it shall be blocked during the tests.

3.2.2.2.5 The side chosen for application of the first impact on the rear of the structure shall be that which, in the opinion of the testing authorities, will result in the application of the series of impacts or loads under the most unfavourable conditions for the structure. The lateral impact and the rear impact shall be applied on both sides of the longitudinal median plane of the protective structure. The front impact shall be applied on the same side of the longitudinal median plane of the protective structure as the lateral impact.

### 3.2.3 Acceptance conditions

3.2.3.1 A protective structure is regarded as having satisfied the strength requirements if it fulfils the following conditions:

3.2.3.1.1 After each part-test it must be free from cracks or tears within the meaning of section 3.3.2.1 or

3.2.3.1.2. If, during one of the tests, significant cracks or tears appear, an additional test, as defined in sections 3.3.1.6 or 3.3.1.7, must be applied immediately after the impact or the crushing test which caused cracks or tears to appear;

3.2.3.1.3 during the tests other than the overload test, no part of the protective structure must enter the clearance zone as defined in 1.6;

3.2.3.1.4 during the tests other than the overload test, all parts of the clearance zone shall be secured by the structure, in accordance with 3.3.2.2;

3.2.3.1.5 during the tests the protective structure must not impose any constraints on the seat structure;

3.2.3.1.6 the elastic deflection, measured in accordance with 3.3.2.4 shall be less than 250 mm.

3.2.3.2 There shall be no accessories presenting a hazard for the driver. There shall be no projecting part or accessory which is liable to injure the driver should the tractor overturn, or any accessory or part which is liable to trap him – for example by the leg or the foot – as a result of the deflections of the structure.

### 3.2.4 Test report

See requirements stated in section 3.2.4 of the main Code.

### 3.2.5 Apparatus and equipment for dynamic tests

#### 3.2.5.1 Pendulum block

3.2.5.1.1 A block acting as a pendulum must be suspended by two chains or wire ropes from pivot points not less than 6 m above the ground. Means must be provided for adjusting independently the suspended height of the block and the angle between the block and the supporting chains or wire ropes.

3.2.5.1.2 The mass of the pendulum block must be  $2\,000 \pm 20$  kg excluding the mass of the chains or wire ropes which themselves must not exceed 100 kg. The length of the sides of the impact face

must be  $680 \pm 20$  mm (see Figure 6.26). The block must be filled in such a way that the position of its centre of gravity is constant and coincides with the geometrical centre of the parallelepiped.

3.2.5.1.3 The parallelepiped must be connected to the system which pulls it backwards by an instantaneous release mechanism which is so designed and located as to enable the pendulum block to be released without causing the parallelepiped to oscillate about its horizontal axis perpendicular to the pendulum's plane of oscillation.

### 3.2.5.2 Pendulum supports

The pendulum pivot points must be rigidly fixed so that their displacement in any direction does not exceed 1 per cent of the height of fall.

### 3.2.5.3 Lashings

3.2.5.3.1 Anchoring rails with the requisite track width and covering the necessary area for lashing the tractor in all the cases illustrated (see Figures 6.23, 6.24 and 6.25) must be rigidly attached to a non-yielding base beneath the pendulum.

3.2.5.3.2 The tractor shall be lashed to the rails by means of wire rope with round strand, fibre core, construction 6 x 19 in accordance with ISO 2408:2017 and a nominal diameter of 13 mm. The metal strands must have an ultimate tensile strength of 1770 MPa.

3.2.5.3.3 The central pivot of an articulated tractor shall be supported and lashed down as appropriate for all tests. For the lateral impact test, the pivot shall also be propped from the side opposite the impact. The front and rear wheels need not be in line if this facilitates the attachment of the wire ropes in the appropriate manner.

### 3.2.5.4 Wheel prop and beam

3.2.5.4.1 A softwood beam of 150 mm square shall be used as a prop for the wheels during the impact tests (see Figures 6.27, 6.28 and 6.29).

3.2.5.4.2 During the lateral impact tests, a softwood beam shall be clamped to the floor to brace the rim of the wheel opposite the side of impact (see Figure 6.29).

### 3.2.5.5 Props and lashings for articulated tractors

3.2.5.5.1 Additional props and lashings must be used for articulated tractors. Their purpose is to ensure that the section of the tractor on which the protective structure is fitted is as rigid as that of a non-articulated tractor.

3.2.5.5.2 Additional specific details are given in the section 3.3.1 for the impact and crushing tests.

### 3.2.5.6 Tyre pressures and deflections

3.2.5.6.1 The tractor tyres shall not be liquid-ballasted and shall be inflated to the pressures prescribed by the tractor manufacturer for field work.

3.2.5.6.2 The lashings shall be tensioned in each particular case such that the tyres undergo a deflection equal to 12 per cent of the tyre wall height (distance between the ground and the lowest point of the rim) before tensioning.



### 3.2.5.7 Crushing rig

A rig as shown in Figure 6.10 shall be capable of exerting a downward force on a protective structure through a rigid beam approximately 250 mm wide connected to the load-applying mechanism by means of universal joints. Suitable axle stands shall be provided so that the tractor tyres do not bear the crushing force.

### 3.2.5.8 Measuring apparatus

The following measuring apparatus is needed:

3.2.5.8.1 device for measuring the elastic deflection (the difference between the maximum momentary deflection and the permanent deflection, (see Figure 6.11).

3.2.5.8.2 device for checking that the protective structure has not entered the clearance zone and that the latter has remained within the structure's protective during the test (see section 3.3.2.2).

## 3.3 *Dynamic test procedure*

### 3.3.1 Impact and crushing tests

#### 3.3.1.1 Impact at the rear

3.3.1.1.1 The tractor shall be so placed in relation to the pendulum block that the block will strike the protective structure when the impact face of the block and the supporting chains or wire ropes are at an angle with the vertical plane **A** equal to **M/100** with a 20° maximum, unless, during deflection, the protective structure at the point of contact forms a greater angle to the vertical. In this case the impact face of the block shall be adjusted by means of an additional support so that it is parallel to the protective structure at the point of impact at the moment of maximum deflection, the supporting chains or wire ropes remaining at the angle defined above.

The suspended height of the block shall be adjusted and necessary steps taken so as to prevent the block from turning about the point of impact.

The point of impact is that part of the protective structure likely to hit the ground first in a rearward overturning accident, normally the upper edge. The position of the centre of gravity of the block is 1/ 6 of the width of the top of the protective structure inwards from a vertical plan parallel to the median plane of the tractor touching the outside extremity of the top of the protective structure.

If the structure is curved or protruding at this point, wedges enabling the impact to be applied thereon must be added, without thereby reinforcing the structure.

3.3.1.1.2 The tractor must be lashed to the ground by means of four wire ropes, one at each end of both axles, arranged as indicated in Figure 6.27. The spacing between the front and rear lashing points must be such that the wire ropes make an angle of less than 30° with the ground. The rear lashings must in addition be so arranged that the point of convergence of the two wire ropes is located in the vertical plane in which the centre of gravity of the pendulum block travels.

The wire ropes must be tensioned so that the tyres undergo the deflections given in 3.2.5.6.2. With the wire ropes tensioned, the wedging beam shall be placed in front of and tight against the rear wheels and then fixed to the ground.

3.3.1.1.3 If the tractor is of the articulated type, the point of articulation shall, in addition, be supported by a wooden block at least 100 mm square and firmly lashed to the ground.

3.3.1.1.4 The pendulum block shall be pulled back so that the height of its centre of gravity above that at the point of impact is given by one of the following two formulae, to be chosen according to the reference mass of the assembly subjected to the tests:

$$H = 25 + 0.07 M$$

for tractor with a reference mass of less than 2 000 kg;

$$H = 125 + 0.02 M$$

for tractor with a reference mass of more than 2 000 kg.

The pendulum block is then released and strikes the protective structure.

3.3.1.1.5 For tractors with a reversible driver's position (reversible seat and steering wheel), the same formulae shall apply.

### 3.3.1.2 Impact at the front

3.3.1.2.1 The tractor shall be so placed in relation to the pendulum block that the block will strike the protective structure when the impact face of the block and the supporting chains or wire ropes are at an angle with the vertical plane A equal to  $M/100$  with a  $20^\circ$  maximum, unless, during deflection, the protective structure at the point of contact forms a greater angle to the vertical. In this case the impact face of the block shall be adjusted by means of an additional support so that it is parallel to the protective structure at the point of impact at the moment of maximum deflection, the supporting chains or wire ropes remaining at the angle defined above.

The suspended height of the pendulum block shall be adjusted and the necessary steps taken so as to prevent the block from turning about the point of impact.

The point of impact is that part of the protective structure likely to hit the ground first if the tractor overturned sideways while travelling forward, normally the upper edge. The position of the centre of gravity of the block is  $1/6$  of the width of the top of the protective structure inwards from a vertical plane parallel to the median plane of the tractor touching the outside extremity of the top of the protective structure.

If the structure is curved or protruding at this point, wedges enabling the impact to be applied thereon must be added, without thereby reinforcing the structure.

3.3.1.2.2 The tractor must be lashed to the ground by means of four wire ropes, one at each end of both axles, arranged as indicated in Figure 6.28. The spacing between the front and rear lashing points must be such that the wire ropes make an angle of less than  $30^\circ$  with the ground. The rear lashings shall in addition be so arranged that the point of convergence of the two wire ropes is located in the vertical plane in which the centre of gravity of the pendulum block travels.

The wire ropes must be tensioned so that the tyres undergo the deflections given in 3.2.5.6.2. With the wire ropes tensioned, the wedging beam shall be placed behind and tight against the rear wheels and then fixed to the ground.

3.3.1.2.3 If the tractor is of the articulated type, the point of articulation shall, in addition, be supported by a wooden block at least 100 mm square and firmly lashed to the ground.

3.3.1.2.4 The pendulum block shall be pulled back so that the height of its centre of gravity above that at the point of impact is given by one of the following two formulae, to be chosen according to the reference mass of the assembly subjected to the tests:

$$H = 25 + 0.07 M$$

for tractor with a reference mass of less than 2 000 kg.

$$H = 125 + 0.02 M$$

for tractor with a reference mass of more than 2 000 kg.

The pendulum block is then released and strikes the protective structure.

3.3.1.2.5 For tractors with a reversible driver's position (reversible seat and steering wheel), the height shall be whichever is greater from the formula applied above and that selected below:

$$H = 2.165 \times 10^{-8} M \times L^2$$

or

$$H = 5.73 \times 10^{-2} I$$

### 3.3.1.3 Impact from the side

3.3.1.3.1 The tractor shall be so placed in relation to the pendulum block that the block will strike the protective structure when the impact face of the block and the supporting chains or wire ropes are vertical unless, during deflection, the protective structure at the point of contact forms an angle of less than 20° to the vertical. In this case the impact face of the block shall be adjusted by means of an additional support so that it is parallel to the protective structure at the point of impact at the moment of maximum deflection, the supporting chains or wire ropes remaining vertical on impact.

The suspended height of the pendulum block shall be adjusted and necessary steps taken so as to prevent the block from turning about the point of impact.

The point of impact shall be that part of the protective structure likely to hit the ground first in a sideways overturning accident.

3.3.1.3.2 The tractor wheels on the side which is to receive the impact must be lashed to the ground by means of wire ropes passing over the corresponding ends of the front and rear axles. The wire ropes must be tensioned to produce the tyre deflection values given in 3.2.5.6.2.

With the wire ropes tensioned, the wedging beam shall be placed on the ground, pushed tight against the tyres on the side opposite that which is to receive the impact and then fixed to the ground. It may be necessary to use two beams or wedges if the outer sides of the front and rear tyres are not in

the same vertical plane. The prop shall then be placed as indicated in Figure 6.29 against the rim of the most heavily loaded wheel opposite to the point of impact, pushed firmly against the rim and then fixed at its base. The length of the prop shall be such that it makes an angle of  $30 \pm 3^\circ$  with the ground when in position against the rim. In addition, its thickness shall, if possible, be between 20 and 25 times less than its length and between 2 and 3 times less than its width. The props shall be shaped at both ends as shown in the details on Figure 6.29.

3.3.1.3.3 If the tractor is of the articulated type, the point of articulation shall in addition be supported by a wooden block at least 100 mm square and laterally supported by a device similar to the prop pushed against the rear wheel as in 3.3.1.3.2. The point of articulation shall then be lashed firmly to the ground.

3.3.1.3.4 The pendulum block shall be pulled back so that the height of its centre of gravity above that at the point of impact is given by one of the following two formulae, to be chosen according to the reference mass of the assembly subjected to the tests:

$$H = (25 + 0.20 M) (B_0 + B) / 2B$$

for tractor with a reference mass of less than 2 000 kg.

$$H = (125 + 0.15 M) (B_0 + B) / 2B$$

for tractor with a reference mass of more than 2 000 kg.

3.3.1.3.5 For reversible tractors, the height shall be whichever is greater of the results obtained from the formulae applicable above and below:

$$H = 25 + 0.2 M$$

for tractor with a reference mass of less than 2 000 kg.

$$H = 125 + 0.15 M$$

for tractor with a reference mass of more than 2 000 kg.

The pendulum block is then released and strikes the protective structure.

#### 3.3.1.4 Crushing at the rear

All provisions are identical to those given in section 3.3.1.4 of the main Code.

#### 3.3.1.5 Crushing at the front

All provisions are identical to those given in section 3.3.1.5 of the main Code.

#### 3.3.1.6 Additional impact tests

If cracks or tears which cannot be considered negligible appear during an impact test, a second, similar test, but with a height of fall of:

$$H' = (H \times 10^{-1}) (12 + 4a) (1 + 2a)^{-1}$$

shall be performed immediately after the impact tests causing these tears or cracks to appear, “**a**” being the ratio of the permanent deformation (**Dp**) to the elastic deformation (**De**):

$$a = Dp / De$$

as measured at the point of impact. The additional permanent deformation due to the second impact shall not exceed 30 per cent of the permanent deformation due to the first impact.

In order to be able to carry out the additional test, it is necessary to measure the elastic deformation during all the impact tests.

### 3.3.1.7 Additional crushing tests

If during a crushing test, significant cracks or tears appear, a second, similar, crushing test, but with a force equal to **1.2 F<sub>v</sub>**, shall be performed immediately after the crushing tests which caused these tears or cracks to appear.

Additional cracks or tears or entry into or lack of protection of the clearance zone, due to elastic deformation, are permitted during the additional crushing test. After removing the load, however, the protective structure shall not infringe on the clearance zone, which shall be completely protected.

## 3.3.2 Measurements to be made

### 3.3.2.1 Fractures and cracks

After each test all structural members, joints and fastening systems shall be visually examined for fractures or cracks, any small cracks in unimportant parts being ignored.

Any tears caused by the edges of the pendulum weight are to be ignored.

### 3.3.2.2 Entry into the clearance zone

During each test the protective structure shall be examined to see whether any part of it has entered the clearance zone round the driving seat as defined in 1.6.

Furthermore, the clearance zone shall not be outside the protection of the protective structure. For this purpose, it shall be considered to be outside the protection of the structure if any part of it would come in contact with flat ground if the tractor overturned towards the direction from which the test load is applied. For estimating this, the front and rear tyres and track width setting shall be the smallest standard fitting specified by the manufacturer.

### 3.3.2.3 Rear hard fixture tests

If the tractor is fitted with a rigid section, a housing or other hard fixture placed behind the driver's seat, this fixture shall be regarded as a protective point, in the event of sideways or rear overturning. This hard fixture placed behind the driver's seat shall be capable of withstanding, without breaking or entering the clearance zone, a downward force **F<sub>i</sub>** where:

$$F_i = 15 M$$

applied perpendicularly to the top of the frame in the central plane of the tractor. The initial angle of application of force shall be 40° calculated from a parallel to the ground as shown in Figure 6.12. The minimum width of this rigid section shall be 500 mm (see Figure 6.13).

In addition, it shall be sufficiently rigid and firmly attached to the rear of the tractor.

#### 3.3.2.4 Elastic deflection (under side impact)

The elastic deflection is measured  $(810 + a_v)$  mm above the index point, in the vertical plane passing through the point of impact. For this measurement, apparatus similar to that illustrated in Figure 6.11 shall be used.

#### 3.3.2.5 Permanent deflection

After the final crushing test, the permanent deflection of the protective structure shall be recorded. For this purpose, before the start of the test, the position of the main roll-over protective structure members in relation to the seat index point shall be used.

### 3.4 ***Extension to other tractor models***

See the provisions stated in the main Code.

### 3.5 ***Labelling***

See the requirements stated in the main Code.

### 3.6 ***Cold weather performance of protective structures***

See the requirements stated in the main Code.

### 3.7 ***Seatbelt anchorage performance (optional)***

See the provisions stated in the main Code.

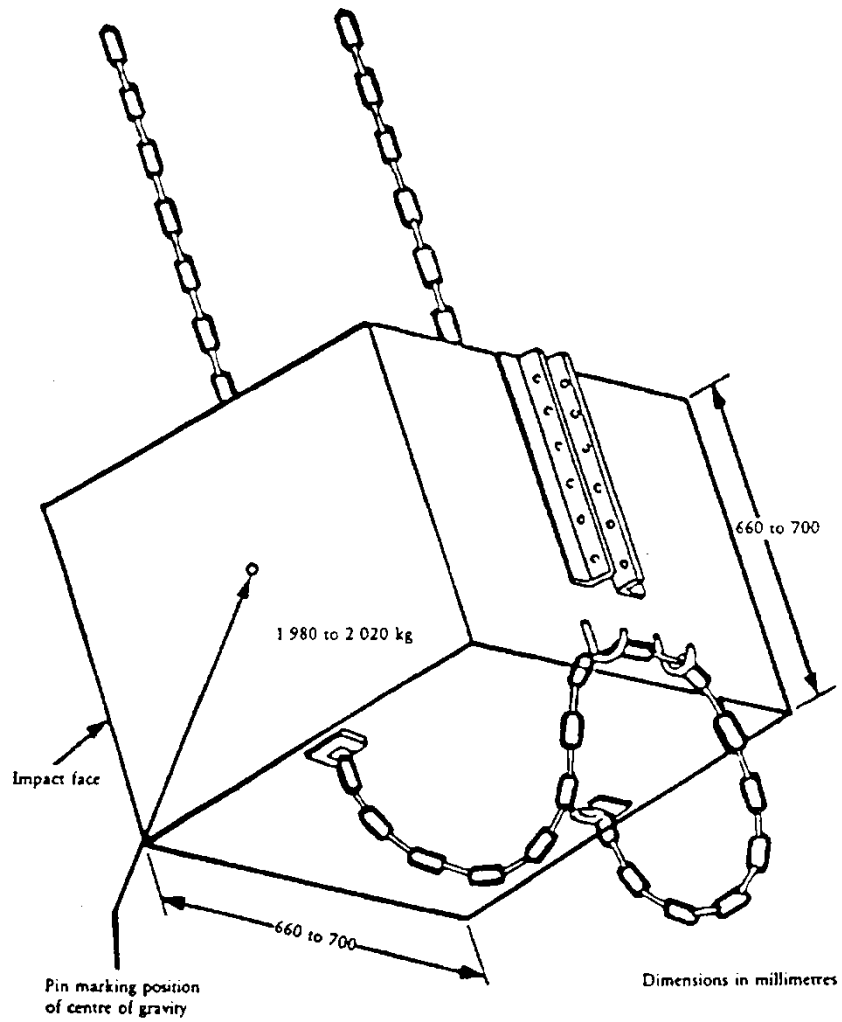

Figure 6.26

**Pendulum block and its suspending chains or wire ropes**

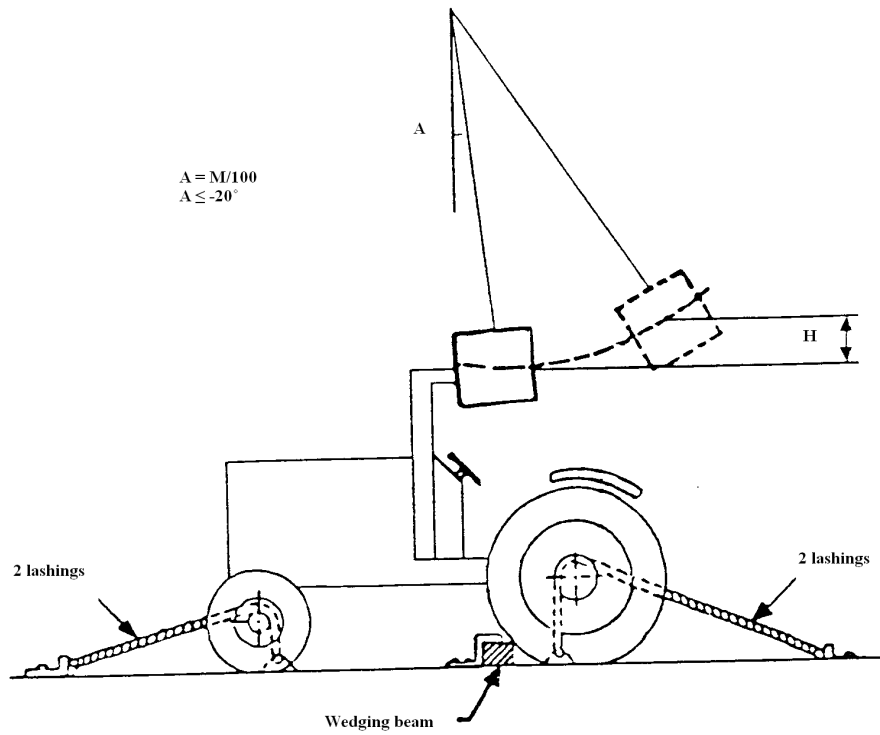

Figure 6.27

**Example of tractor lashing (rear impact)**

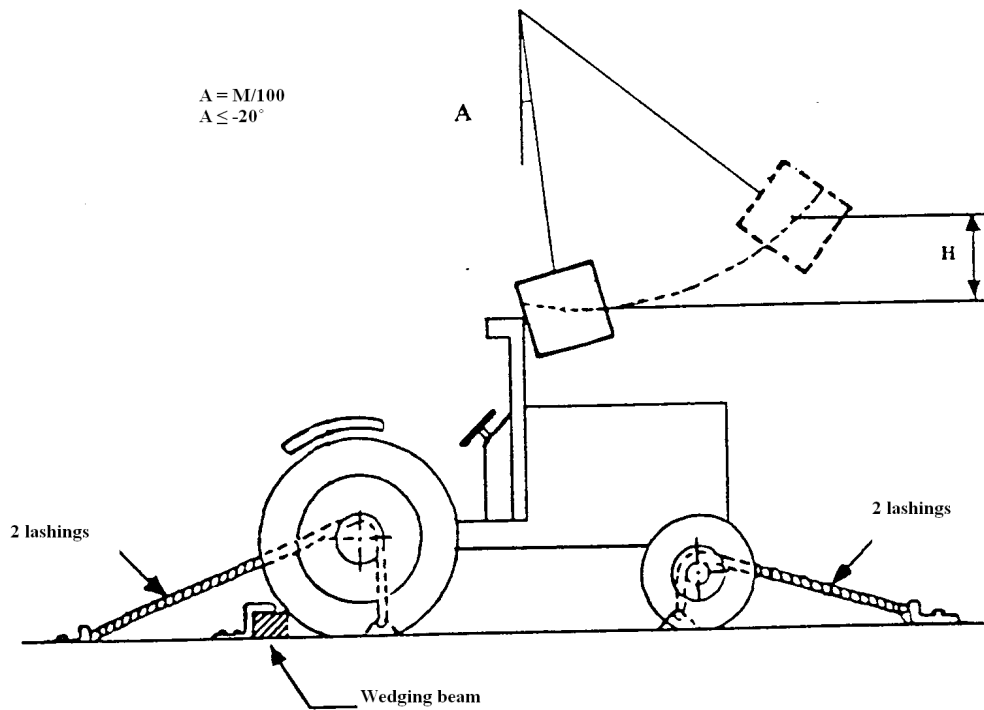

Figure 6.28

**Example of tractor lashing (front impact)**



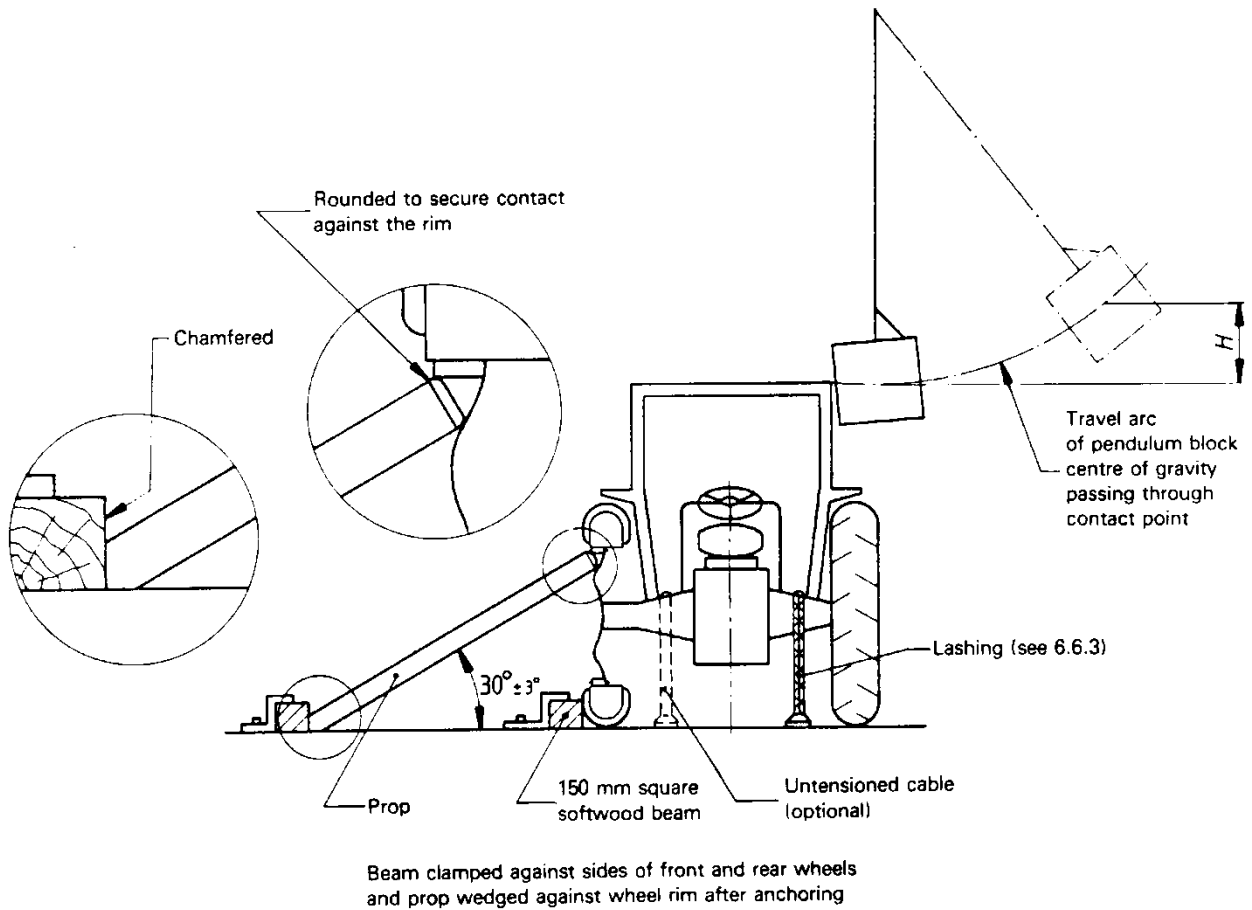

Figure 6.29

**Example of tractor lashing (side impact)**

---

# NEW AMENDMENTS IN THE 2024 EDITION OF THE OECD TRACTOR CODES

---

## Background

The 2024 edition of the Tractor Codes, released on 1 February 2024, incorporates several amendments as approved by the 2023 Annual Meeting.

Amendments:

### **General texts**

Increase of the Basic fee to 4,000 EUR

#### **Code 2**

No change

#### **Code 3**

No change

#### **Code 4**

No change

#### **Code 5**

No change

#### **Code 6**

No change

#### **Code 7**

No change

#### **Code 8**

No Change

#### **Code 9**

No change

#### **Code 10**

No change